



HIGH SPEED PRECISION LATHE

OPERATOR'S & SPARE PARTS MANUAL

Digital Variable Speed Series

For Models : 1640LV, 1660LV, 1860LV, 1880LV

Sharp Industries, Inc.
3501 Challenger Street
Torrance, CA 9050. USA
Tel (310) 370-5990, Fax (310) 542-6162

CONTENTS

PREFACE	3
1. SHARP DIGITAL VARIABLE SPEED LATHE	
1-1 Machine Assembly	5
2. UNPACKING & MACHINE INSTALLATION	
2-1 Unpacking.....	7
2-2 Lifting.....	7
2-3 Basic Foundation	8
2-4 Cleaning	8
2-5 Leveling	8
3. ELECTRICAL CIRCUIT CONTROL	
3-1 Electrical Wiring	9
3-2 Electrical Equipment.....	9
3-3 Electrical Cautions.....	9
4. TESTING & OPERATION	
4-1 Operation Symbols	10
4-2 Transmission & Spindle Operation	11
4-3 Spindle Speed Selection	11
4-4 Intermittent Operation of Spindle.....	12
4-5 The Importance and Methods of Spindle Balancing.....	13
4-6 Transmitting Power to the Gear Box.....	13
4-7 Gear Box Operation	14
4-8 Manual Operation	14
4-9 Automatic Feed.....	15
4-10 Automatic Feed Stop.....	15
4-11 4 Position Automatic Feed Stop	15
4-12 Tailstock Operation	16

CONTENTS

5. THREADING

5-1 Leadscrew Drive	16
5-2 Threading	16
5-3 Thread Dial Indicator	17
5-4 Thread & Feed Chart.....	18
5-5 Module & D.P. Thread Chart	24

6. LUBRICATION

6-1 Headstock Lubrication	28
6-2 Gear Box & Apron Lubrication	28
6-3 Lubrication Charts	28

7. MAINTENANCE & ADJUSTMENT

7-1 Headstock	29
7-2 Apron & Saddle	30
7-3 Gear Box.....	31
7-4 Tailstock Adjustment.....	31
7-5 Belt Tension Adjustment.....	33
7-6 Brake Belt Adjustment.....	33
7-7 Brake & Micro Switch Adjustment	34
7-8 Leadscrew Backlash Adjustment.....	34
7-9 Coolant Pump.....	35

8. TAPER ATTACHMENT.....35

PREFACE

Thank you for choosing Sharp as your choice for Digital Variable Speed Lathe. We at Sharp take pride in the workmanship, durability and precision of our machines.

Read this manual in its entirety in order to get the best possible results from the machine and prolong its life, and become familiar with its operation, safety features and recommended maintenance.

The 1 year warranty would be void if the machine was damaged due to improper use or disregard to any operational instruction contained in this manual.

Some precautions to be taken not listed later in this manual are:

1. Do **NOT** install the machine in direct sunlight or directly in front of any cooling system blowers.
2. Use only recommended lubricants.
3. Always keep machine clean
4. Should the ways become damaged do not move the carriage until they have been repaired.

Read the following instructions before operating the machine.

- ◆ Only authorized personnel should work on this machine. Untrained personnel present a hazard to themselves and the machine, and improper operation will void the warranty.
- ◆ Check for damaged parts and tools before operating the machine. Any part or tool that is damaged should be properly repaired or replaced by authorized personnel. Do not operate the machine if any component does not appear to be functioning correctly.
- ◆ Use appropriate eye and ear protection while operating the machine. ANSI-approved impact safety goggles and OSHA-approved ear protection are recommended to reduce the risks of sight damage and hearing loss.
- ◆ The Emergency Stop button is the large, circular red switch located on the Control Panel. Pressing the Emergency Stop button will instantly stop all motion of the machine.
- ◆ The electrical panel should be closed and the key and latches on the electrical cabinet should be secured at all times except during installation and service. At those times, only qualified electricians should have access to the panel. When the main circuit breaker is on, there is high voltage throughout the electrical panel. Once the machine is installed, the electrical cabinet must be locked and the key available only to qualified service personnel.
- ◆ DO NOT modify or alter this equipment in any way. If modifications are necessary, all such requests must be handled by SHARP INDUSTRIES, INC. Any modify action or alteration of any sharp MACHINES could lead to personal injury and/or mechanical damage and will void your warranty

1. SHARP DIGITAL VARIABLE SPEED LATHE

1-1 Machine Assembly

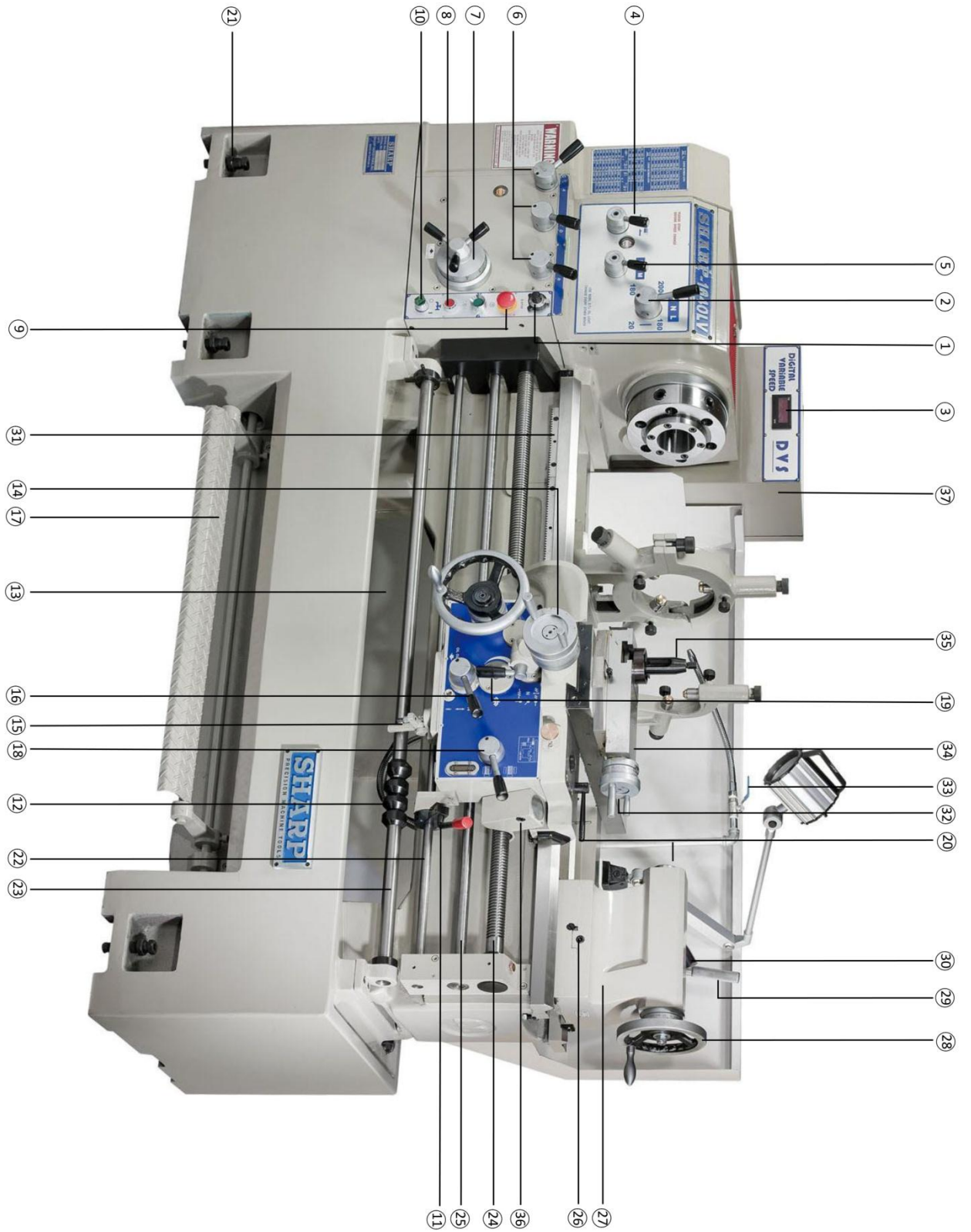

ITEM	DESCRIPTION	ITEM	DESCRIPTION
1	Spindle speed control switch	20	Carriage clamping lever
2	Spindle speed H/L shifting lever	21	Foundation adjusting bolt
3	Speed display	22	Spindle operation control rod
4	Forward/Reverse Shifting lever	23	4 position automatic feed stop selection rod
5	Thread/Feed Selection lever	24	Leadscrew
6	Thread/Feed Shifting lever	25	Auto-feed rod
7	10-step feed selection dial	26	Tailstock set over adjusting Screw
8	Alarm removing button	27	Tailstock body
9	Intermittent button	28	Tailstock handwheel
10	Coolant supply button	29	Tailstock body Clamping lever
11	Spindle operation control lever	30	Tailstock spindle locking lever
12	Adjustable trip dog	31	Rack
13	Longitudinal feed hand wheel	32	Compound rest handle
14	Cross slide handle	33	Coolant control valve
15	Trip plunger	34	Compound rest
16	Auto feeding engaged lever	35	American tool post
17	Foot brake pedal	36	Thread dial indicator
18	Half nut engaged lever	37	Electric Cabinet
19	Feed axis selector		

2. UNPACKING & MACHINE INSTALLATION

2-1 Unpacking

When the machine is arrives:

Check first to see if the crate or container is damaged.

Open the case and inspect for any damage to the machine or missing parts.

If you find any damage or missing parts, contact our company or the appropriate insurance company immediately.

Failure to report any discrepancies or damage immediately could result in a delay or the possibility of a claim being denied.

2-2 Lifting

Please refer to figure 2-2 for unloading and moving of machine.

1. Use hanging jig to lift the machine.
2. Locate the jig at approximately the center of the lathe.
3. Move apron and tailstock towards the end of bed to balance the weight.
4. To insure the accuracy of machine, not to jar the machine when it on its foundation.
5. The backside of the machine should be at least 600mm away from any wall or obstruction to obtain sufficient space for wiring the electric cabinet.



Fig.2-2

2-3 Basic Foundation

With today's common use of tungsten carbide cutting tools, heavy cutting practices and higher spindle speeds, a good machine foundation is a must to avoid vibration. Please refer to figure 2-3 for recommended foundation.

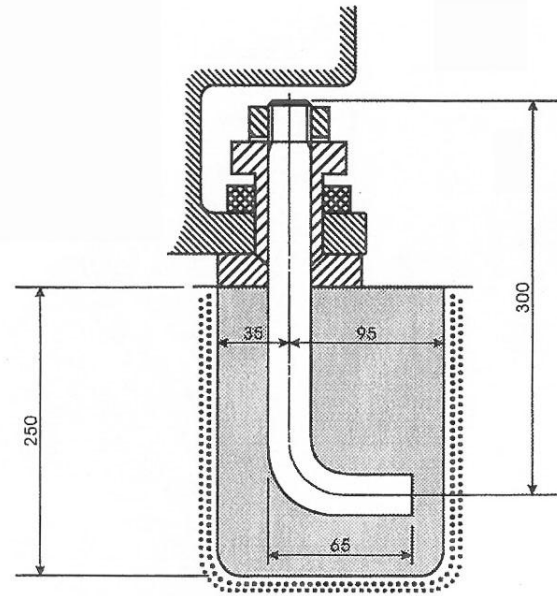

UNIT-mm

Fig.2-3

2-4 Cleaning

Before shipping, the machine is protected with a special anti-rust agent. Before operating the machine, this agent must be removed. This can be done using a soft brush/cloth soaked with cleaning solvent or kerosene. To avoid the danger of fire or explosion, do **NOT** use gasoline or cellulose solvent. After the anti-rust agent is removed, the machine should be properly lubricated and all moving parts be checked for proper operation.

2-5 Leveling

Once the machine is on its foundation it is time for leveling. A machinist level (accuracy 0.02mm/1000mm) should be used. Place level on bed to level machine for longitudinal and transverse leveling. Tighten foundation bolts, and recheck. If not level, loosen foundation bolts and re-level machine. Tolerance should be within 0.04mm/1000mm. (See Figure 2-5)



Fig.2-5

3. ELECTRICAL CIRCUIT CONTROL

3-1 Electrical wiring

The electrical wiring can be found by opening the electrical control box located on the back of the machine. Connect the power source to the terminals labeled R.S.T. (For 16” & 18” use 8 gauge wire, for 22” & 26” use 4 gauge wire). The connection between the power source and the machine should be equipped with a safety fuse. Also make sure the machine is grounded.



3-2 Electrical Equipment















1. To protect the motor from burning out due to an overload, the electrical control box is equipped with an overload circuit breaker and magnetic contactor.
2. A micro switch protects the main switch.
3. The foot brake is connected to a micro switch. Stepping on the foot brake stops the lathe much faster than turning off the switch. After using the foot brake. The forward/reverse lever must be returned to neutral before the spindle can be operated.
4. The spindle will rotate continuously as long as intermittent button $\text{\textcircled{T}}$ is depressed.

3-3 Electrical Cautions

After wiring, the rotation of the spindle must be checked. To do this, turn the main switch to “ON” and push the intermittent button $\text{\textcircled{T}}$, if the rotation is counter clockwise (looking from the tailstock), the rotation is correct. If the rotation is clockwise, changing any two of the three wires R.S.T. will correct the problem.

4. TESTING & OPERATION

4-1 Operation Symbols

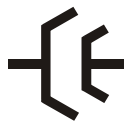
1	HIGH	High speed revolution	11		Variable adjustment (pressure) Clockwise: pressure increase Counterclockwise: pressure decrease
2	LOW	Low speed revolution	12		Electrical control box
3		Forward revolution	13		Imperial threads
4		Neutral gear	14		Metric threads
5		Reverse revolution	15		Auto feeding Rate per revolution
6		Feeding	16		Pump
7		Intermittent button	17		Power switch-ON
8		Cross feeding	18		Power switch-OFF
9		Longitudinal feeding	19	OIL	Oil inlet (hole)
10		Cone clutch			

4-2 Transmission & Spindle Operation

After all the previously described procedures have been done, it is time to test the machine. Position the spindle H/L lever ② to “L”, turn speed control button ① counterclockwise to lowest speed and forward/reverse lever ④ to the “N” position. Lift the spindle operation control lever (Ⓜ of item 1-1), and the spindle will rotate in the forward direction. To reverse spindle direction, push the lever down. Place lever in neutral to stop spindle. The foot brake is used for emergency stop. After using the foot brake, the forward/reverse lever must be returned to neutral before the spindle can be operated again.

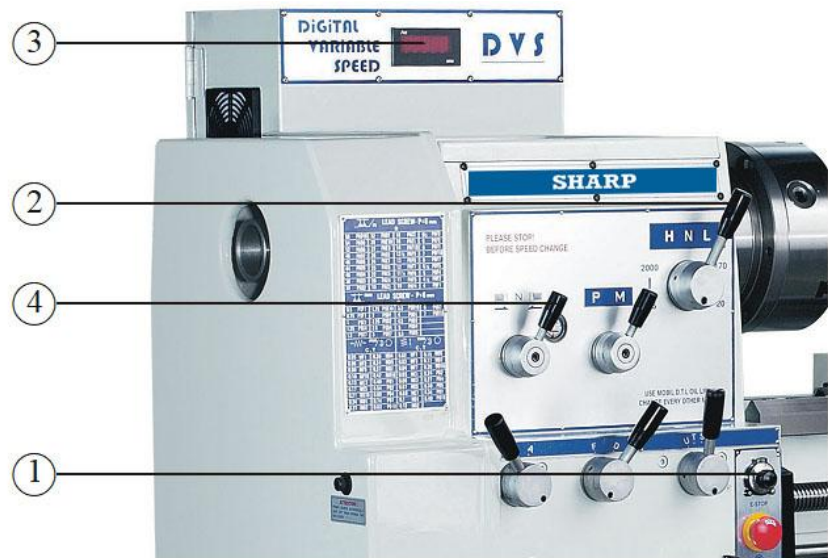

Fig.4-2

4-3 Spindle Speed Selection

There are three speeds on variable speed lathe: H (High), N (Neutral) and L (Low) position. Spindle Bore (2”/ 58mm) : Speed range at H is from 235 to 2000rpm , at L is from 20 to 170 rpm.(Fig 4-3-1) ; Spindle Bore(3”/ 80mm) : Speed range at H is from 180 to 2000rpm , at L is from 20 to 180 rpm. (Fig4-3-2)

Turn speed control button ① counterclockwise to the lowest speed and select speed range by turning lever ② to proper position, then lift or press down spindle operation control lever (Ⓜ of item 1-1) to start spindle. Rotate speed control button ① to choose applicable speed, clockwise for speeding up and counterclockwise for slowing down. Spindle speed shows on display ③.

For safety consideration and to protect the gears from damage, spindle speed H/L lever ② can be shifted only when the motor is completely stopped. If the gears do not engage easily, use intermittent button ① to engage gears. Be sure gears are properly engaged before starting lathe.

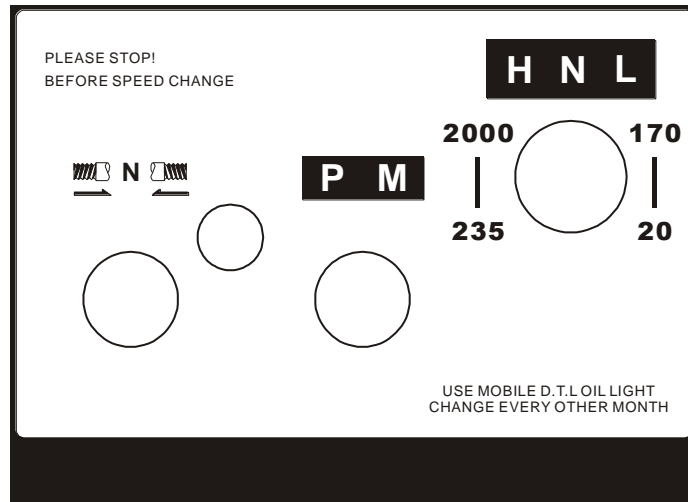

Fig.4-3-1 (Spindle Bore : 2"/ 58mm)

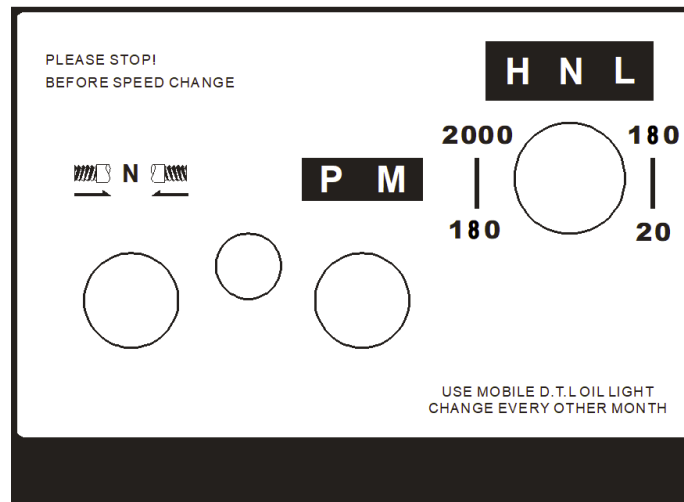
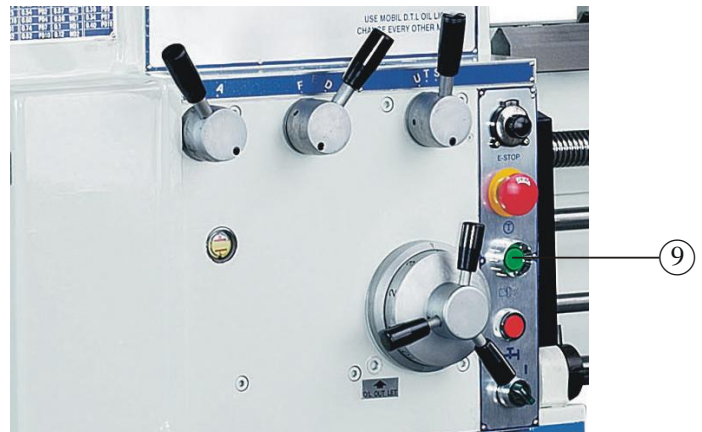

Fig.4-3-2 (Spindle Bore : 3"/ 80mm)

4-4 Intermittent Operation of Spindle

The lathe has been equipped with an intermittent button ⑨ to simplify speed changes, check rotation and work piece centerline. This function only works in the forward direction.



4-5 The Importance and Method of Spindle Balancing

1. A lathe with a spindle that is out of balance can cause chatter and a poor finish on the workpiece. To ensure proper spindle balance, our lathes are equipped with balancing weights located on the locking ring at the rear of the spindle.
2. To properly balance the spindle, first run the lathe at 1350rpm. Put the palm of your hand on the headstock and check for any vibration. Moving the balance weights left or right can eliminate any vibration detected.

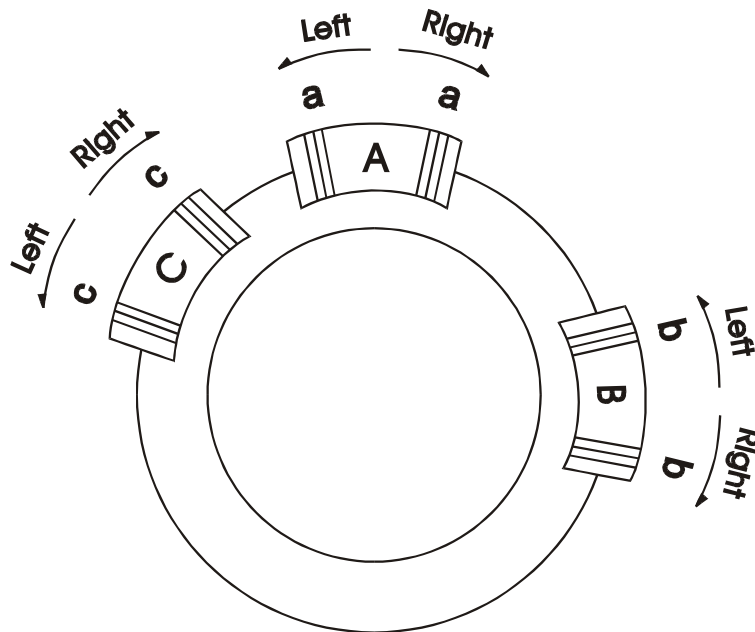

4-6 Transmitting Power to the Gear Box

Lever ④ of item 1-1, controls the direction of the lead screw. This lever has three positions, Left, Right and Neutral.

4-7 Gear Box Operation

1. Threading:

With our special design, there is no need to re-arrange the back gears for threading. Please refer to the threading and feed tables for correct settings. The levers used for setting the feed rate or T.P.I. are:

- a. Feed direction ④ of item 1-1.
- b. Thread/Feed lever ⑤ of item 1-1.
- c. Thread/Feed lever ⑥ of item 1-1.
- d. 10 step selection dial ⑦ of item 1-1.

2. Auto feed:

After selecting the proper setting for either feed rate or threading you can use the appropriate lever for the desired operation. Auto feed ⑯ of item 1-1, or half nut engagement lever ⑱ of item 1-1.

4-8 Manual Operation

For manual operation, move both the half nut lever ⑱ and lever ④ of item 1-1 to neutral position. Hand wheel ⑬ Fig. 4-8 controls the apron movement, ⑭ controls the cross slide and ⑳ controls the compound. The graduations on all the dials are graduated in both metric and inch. Metric is 0.02mm per graduation and inch is. **0.001”** per graduation.



Fig.4-8

4-9 Automatic feed

1. Position lever ④ of item 1-1 to the required position.
2. Move lever ⑤ & ⑥ of item 1-1 to the desired feed rate or thread.
3. For threading, use lever ⑱ of item 1-1. Be sure lever is fully engaged.
4. For cross feed, push the feed axis selector lever ⑲ of item 1-1 down.
5. To reverse the cross feed, pull the feed axis selector lever ⑲ of item 1-1 up.

4-10 Automatic Feed Stop

The apron is equipped with an automatic stop device. To set this stop, loosen the setscrew on the top of the dog ⑫ Fig. 4-10 and move to the desired location. With the dog in place and the top tip facing out tighten the setscrew. When the dog comes in contact with the trip plunger (⑮ of item 1-1 located at the bottom of the apron) the carriage will stop. Always test the stop before you start machining to avoid damage to the lathe and or workpiece.



Fig.4-10

4-11 4 Position Automatic Feed Stop

This feature gives you the option to set up to 4 stops. Dogs are set individually and can be set to trip the plunger going in either direction. If the dog is not needed, simply turn it so the top tip is facing inward and the plunger arm will pass by it.

4-12 Tailstock Operation

1. The tailstock handwheel dial is divided in 0.001" per graduation. Rotating the handwheel clockwise moves the quill out, counterclockwise retracts the quill. Retracting quill will release the center or other tool being used.
2. To lock the quill, push locking lever forward. (③⑩ Fig. 4-12).
3. The centerline of the tailstock can be adjusted using set-over adjusting screw ②⑥ Fig.4-12. After adjusting, be sure to tighten screws on both sides.

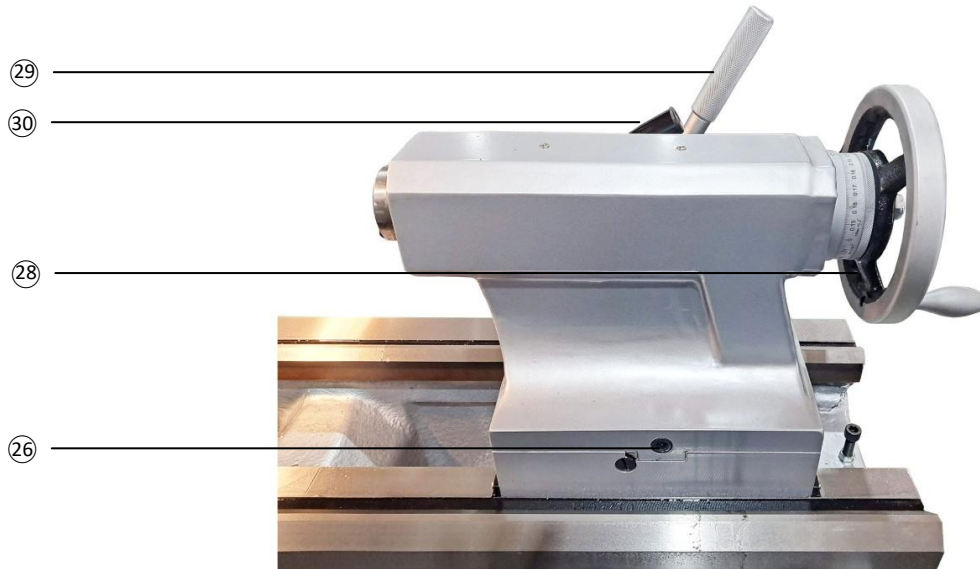

Fig.4-12

5. THREADING

5-1 Leadscrew Drive.

Moving the Forward/Reverse lever (④ of item 1-1) to the right will cause the leadscrew to rotate backwards, moving the lever to the left the leadscrew will rotate forward and when the lever is in neutral the leadscrew will stop.

5-2 Threading

1. After selecting the thread to be cut, set the following levers to the appropriate position: ⑤, ⑥ & ⑦ of item 1-1. (Example 18 T.P.I. : PAE2)
2. Turn on the lathe.
3. Engage the halfnut by pushing ⑱ of item 1-1 down, making sure it is fully engaged.

5-3 Thread Dial Indicator

1. Thread dial indicator for Imperial leadscrew

To cut even number threads the leadscrew can be engaged on any number or line. For odd number threads the leadscrew can be engaged on any number. Fractional threads (1/2, 1/4 etc.), leadscrew can only be engaged on the same number or line.

Note: When cutting metric threads on a lathe with an Imperial leadscrew, be sure the half nut is engaged at all times. (If not, the thread will not repeat).



2. Thread dial indicator for Metric leadscrew for cutting metric threads.

There are two dials used for metric leadscrews, 2&7 divisions and 3&5 divisions. To cut threads with pitches of 1.25, 2.5, 5.0, 2.25 and 4.5, use the 3&5 division dial. For the balance of threads use the 2&7 division dial. For cutting thread pitches of 0.5, 0.75, 1.0, 1.5, 2.0, 3.0, 4.0 and 6.0, use the 14T worm gear and the 2&7 division dial. The Maximum number of divisions on the dial are 7, however, you can only engage the dial on 2 of these numbers.

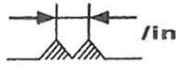
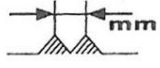

Gear Teeth	Pitch		Dial Division	Halfnuts Engaged Number
11T	2.75	5.5	2	1
13T	3.25	6.5	2	1
14T	1.75	3.5	2	1,2
	7			
	0.5	0.75	7	1,2,3,4,5,6,7
	1	1.5		
	2	3		
	4	6		
15T	1.25	2.5	3	1,2,3
	5			
	2.25	4.5	5	1,2,3
18T	6.75		2	1,2

5-4 Thread & Feed Chart



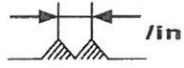

For Swing 16" , 18" , 20" (410mm, 460mm, 510mm) Series while Metric Leadscrew & Metric Feed

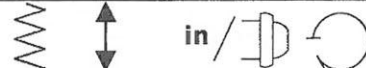
 LEAD SCREW-P=6mm R							
56	PAD10	32	PAD1	18	PAE2	9 1/2	PAF3
54	PAD9	28	PAE10	16	PAE1	9	PAF2
52	PAD8	27	PAE9	14	PAF10	8	PAF1
48	PAD7	26	PAE8	13 1/2	PAF9	7	PBF10
46	PAD6	24	PAE7	13	PAF8	6	PBF7
44	PAD5	23	PAE6	12	PAF7	5 1/2	PBF5
40	PAD4	22	PAE5	11 1/2	PAF6	5	PBF4
38	PAD3	20	PAE4	11	PAF5	4 1/2	PBF2
36	PAD2	19	PAE3	10	PAF4	4	PBF1
 LEAD SCREW-P=6mm C							
0.5	PSF1	1.75	PSE10	3.5	PSD10	6	PUD7
0.75	PSF7	2	PSD1	4	PUD1	7	PUD10
1	PSE1	2.25	PSD2	4.5	PUD2		
1.25	PSE4	2.5	PSD4	5	PUD4		
1.5	PSE7	3	PSD7	5.5	PUD5		
 C.T.				 C.T.			
0.05	MF1	0.30	MD4	0.02	MF1	0.15	MD5
0.06	MF2	0.34	MD5	0.03	MF3	0.17	MD7
0.08	MF5	0.37	MD7	0.04	MF7	0.20	MD10
0.10	MF10	0.42	MD10	0.05	ME1	0.24	PD2
0.13	ME2	0.48	PD1	0.06	ME3	0.27	PD4
0.17	ME5	0.54	PD2	0.07	ME5	0.30	PD5
0.21	ME10	0.60	PD4	0.08	ME7	0.34	PD7
0.24	MD1	0.74	PD7	0.1	MD1	0.40	PD10
0.27	MD2	0.82	PD10	0.12	MD2		





For Swing 16" , 18" , 20" (410mm, 460mm, 510mm) Series while Imperial Leadscrew & Imperial Feed

				LEAD SCREW - 4TPI			
				R			
56	PAD10	32	PAD1	18	PAE2	9 1/2	PAF3
54	PAD9	28	PAE10	16	PAE1	9	PAF2
52	PAD8	27	PAE9	14	PAF10	8	PAF1
48	PAD7	26	PAE8	13 1/2	PAF9	7	PBF10
46	PAD6	24	PAE7	13	PAF8	6	PBF7
44	PAD5	23	PAE6	12	PAF7	5 1/2	PBF5
40	PAD4	22	PAE5	11 1/2	PAF6	5	PBF4
38	PAD3	20	PAE4	11	PAF5	4 1/2	PBF2
36	PAD2	19	PAE3	10	PAF4	4	PBF1
				LEAD SCREW-P - 4TPI			
				C			
0.5	PSF1	1.75	PSE10	3.5	PSD10	6	PUD7
0.75	PSF7	2	PSD1	4	PUD1	7	PUD10
1	PSE1	2.25	PSD2	4.5	PUD2		
1.25	PSE4	2.5	PSD4	5	PUD4		
1.5	PSE7	3	PSD7	5.5	PUD5		
							
C.T.				C.T.			
0.002	MF1	0.001	MD4	0.001	MF7	0.0043	MD8
0.0025	MF2	0.012	MD5	0.0012	MF10	0.0047	MD10
0.0031	MF5	0.014	MD7	0.0015	ME2	0.0052	PD1
0.0039	MF10	0.016	MD10	0.0017	ME4	0.0060	PD2
0.0051	ME2	0.018	PD1	0.002	ME7	0.0071	PD5
0.006	ME5	0.020	PD2	0.0023	ME10	0.0078	PD7
0.008	ME10	0.023	PD4	0.0026	MD1	0.0086	PD8
0.009	MD1	0.027	PD7	0.0030	MD2	0.0094	PD10
0.010	MD2	0.032	PD10	0.0036	MD5		

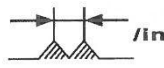
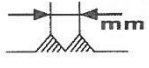

For Swing 16" , 18" , 20" (410mm, 460mm, 510mm) Series while Imperial Leadscrew but Metric Feed.

		LEAD SCREW – 4TPI					
R							
56	PAD10	32	PAD1	18	PAE2	9 1/2	PAF3
54	PAD9	28	PAE10	16	PAE1	9	PAF2
52	PAD8	27	PAE9	14	PAF10	8	PAF1
48	PAD7	26	PAE8	13 1/2	PAF9	7	PBF10
46	PAD6	24	PAE7	13	PAF8	6	PBF7
44	PAD5	23	PAE6	12	PAF7	5 1/2	PBF5
40	PAD4	22	PAE5	11 1/2	PAF6	5	PBF4
38	PAD3	20	PAE4	11	PAF5	4 1/2	PBF2
36	PAD2	19	PAE3	10	PAF4	4	PBF1
		LEAD SCREW – 4TPI					
C							
0.5	PSF1	1.75	PSE10	3.5	PSD10	6	PUD7
0.75	PSF7	2	PSD1	4	PUD1	7	PUD10
1	PSE1	2.25	PSD2	4.5	PUD2		
1.25	PSE4	2.5	PSD4	5	PUD4		
1.5	PSE7	3	PSD7	5.5	PUD5		
							
C.T.		C.T.					
0.05	MF1	0.29	MD4	0.02	MF1	0.14	MD5
0.06	MF2	0.32	MD5	0.03	MF3	0.16	MD7
0.08	MF5	0.35	MD7	0.04	MF7	0.18	MD10
0.10	MF10	0.40	MD10	0.05	ME1	0.2	PD1
0.13	ME2	0.45	PD1	0.06	ME3	0.24	PD2
0.16	ME5	0.52	PD2	0.07	ME5	0.28	PD5
0.20	ME10	0.58	PD4	0.08	ME7	0.32	PD7
0.23	MD1	0.70	PD7	0.1	MD1	0.36	PD10
0.26	MD2	0.80	PD10	0.12	MD2		

For Swing 22" , 26" (560mm, 660mm) Series while Metric Leadscrew & Metric Feed

 LEAD SCREW-P=6mm R							
56	KAD10	27	KAE9	13	KAF8	5	KBF4
54	KAD9	26	KAE8	12	KAF7	4 1/2	KBF2
52	KAD8	24	KAE7	11 1/2	KAF6	4	KBF1
48	KAD7	23	KAE6	11	KAF5	3 1/2	JBF10
46	KAD6	22	KAE5	10	KAF4	3 1/4	JBF8
44	KAD5	20	KAE4	9 1/2	KAF3	3	JBF7
40	KAD4	19	KAE3	9	KAF2	2 7/8	JBF6
38	KAD3	18	KAE2	8	KAF1	2 3/4	JBF5
36	KAD2	16	KAE1	7	KBF10	2 1/2	JBF4
32	KAD1	14	KAF10	6	KBF7	2 1/4	JBF2
28	KAE10	13 1/2	KAF9	5 1/2	KBF5	2	JBF1
 LEAD SCREW-P=6mm C							
0.5	KSF1	2	KSD1	4.5	KUD2	9	JUD2
0.75	KSF7	2.25	KSD2	5	KUD4	10	JUD4
1	KSE1	2.5	KSD4	5.5	KUD5	11	JUD5
1.25	KSE4	3	KSD7	6	KUD7	12	JUD7
1.5	KSE7	3.5	KSD10	7	KUD10	13	JUD8
1.75	KSE10	4	KUD1	8	JUD1	14	JUD10
 mm/  C.T.				 mm/  C.T.			
0.05	KF1	0.30	KD4	0.02	KF1	0.15	KD5
0.06	KF2	0.34	KD5	0.03	KF3	0.17	KD7
0.08	KF5	0.37	KD7	0.04	KF7	0.20	KD10
0.10	KF10	0.42	KD10	0.05	KE1	0.24	JD2
0.13	KE2	0.48	JD1	0.06	KE3	0.27	JD4
0.17	KE5	0.54	JD2	0.07	KE5	0.30	JD5
0.21	KE10	0.60	JD4	0.08	KE7	0.34	JD7
0.24	KD1	0.74	JD7	0.1	KD1	0.40	JD10
0.27	KD2	0.82	JD10	0.12	KD2		

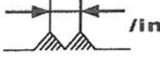
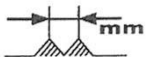
For Swing 22" , 26" (560mm, 660mm) Series while Imperial Leadscrew & Imperial Feed

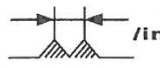
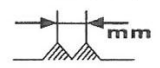
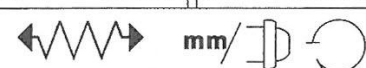
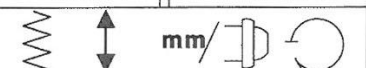

				LEAD SCREW - 4TPI			
				R			
56	KAD10	27	KAE9	13	KAF8	5	KBF4
54	KAD9	26	KAE8	12	KAF7	4 1/2	KBF2
52	KAD8	24	KAE7	11 1/2	KAF6	4	KBF1
48	KAD7	23	KAE6	11	KAF5	3 1/2	JBF10
46	KAD6	22	KAE5	10	KAF4	3 1/4	JBF8
44	KAD5	20	KAE4	9 1/2	KAF3	3	JBF7
40	KAD4	19	KAE3	9	KAF2	2 7/8	JBF6
38	KAD3	18	KAE2	8	KAF1	2 3/4	JBF5
36	KAD2	16	KAE1	7	KBF10	2 1/2	JBF4
32	KAD1	14	KAF10	6	KBF7	2 1/4	JBF2
28	KAE10	13 1/2	KAF9	5 1/2	KBF5	2	JBF1
				LEAD SCREW - 4TPI			
				C			
0.5	KSF1	2	KSD1	4.5	KUD2	9	JUD2
0.75	KSF7	2.25	KSD2	5	KUD4	10	JUD4
1	KSE1	2.5	KSD4	5.5	KUD5	11	JUD5
1.25	KSE4	3	KSD7	6	KUD7	12	JUD7
1.5	KSE7	3.5	KSD10	7	KUD10	13	JUD8
1.75	KSE10	4	KUD1	8	JUD1	14	JUD10
							
C.T.				C.T.			
0.002	KF1	0.011	KD4	0.001	KF7	0.0043	KD8
0.0025	KF2	0.012	KD5	0.0012	KF10	0.0047	KD10
0.0031	KF5	0.014	KD7	0.0015	KE2	0.0052	JD1
0.0039	KF10	0.016	KD10	0.0017	KE4	0.0060	JD2
0.0051	KE2	0.018	JD1	0.002	KE7	0.0071	JD5
0.006	KE5	0.020	JD2	0.0023	KE10	0.0078	JD7
0.008	KE10	0.023	JD4	0.0026	KD1	0.0086	JD8
0.009	KD1	0.027	JD7	0.0030	KD2	0.0094	JD10
0.010	KD2	0.032	JD10	0.0036	KD5		

For Swing 22" , 26" (560mm, 660mm) Series while Imperial Leadscrew but Metric Feed

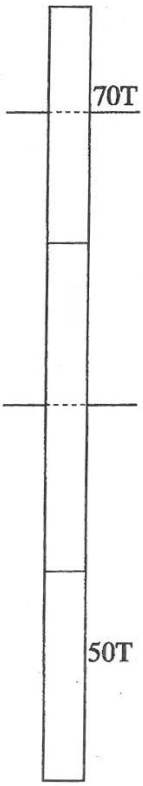
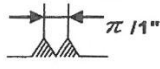

				LEAD SCREW – 4TPI			
R							
56	KAD10	27	KAE9	13	KAF8	5	KBF4
54	KAD9	26	KAE8	12	KAF7	4 1/2	KBF2
52	KAD8	24	KAE7	11 1/2	KAF6	4	KBF1
48	KAD7	23	KAE6	11	KAF5	3 1/2	JBF10
46	KAD6	22	KAE5	10	KAF4	3 1/4	JBF8
44	KAD5	20	KAE4	9 1/2	KAF3	3	JBF7
40	KAD4	19	KAE3	9	KAF2	2 7/8	JBF6
38	KAD3	18	KAE2	8	KAF1	2 3/4	JBF5
36	KAD2	16	KAE1	7	KBF10	2 1/2	JBF4
32	KAD1	14	KAF10	6	KBF7	2 1/4	JBF2
28	KAE10	13 1/2	KAF9	5 1/2	KBF5	2	JBF1
				LEAD SCREW – 4TPI			
C							
0.5	KSF1	2	KSD1	4.5	KUD2	9	JUD2
0.75	KSF7	2.25	KSD2	5	KUD4	10	JUD4
1	KSE1	2.5	KSD4	5.5	KUD5	11	JUD5
1.25	KSE4	3	KSD7	6	KUD7	12	JUD7
1.5	KSE7	3.5	KSD10	7	KUD10	13	JUD8
1.75	KSE10	4	KUD1	8	JUD1	14	JUD10
							
C.T.				C.T.			
0.05	KF1	0.29	KD4	0.02	KF1	0.14	KD5
0.06	KF2	0.32	KD5	0.03	KF3	0.16	KD7
0.08	KF5	0.35	KD7	0.04	KF7	0.18	KD10
0.10	KF10	0.40	KD10	0.05	KE1	0.20	JD1
0.13	KE2	0.45	JD1	0.06	KE3	0.24	JD2
0.16	KE5	0.52	JD2	0.07	KE5	0.28	JD5
0.20	KE10	0.58	JD4	0.08	KE7	0.32	JD7
0.23	KD1	0.70	JD7	0.1	KD1	0.36	JD10
0.26	KD2	0.80	JD10	0.12	KD2		

5-5 Module & D.P Thread Chart

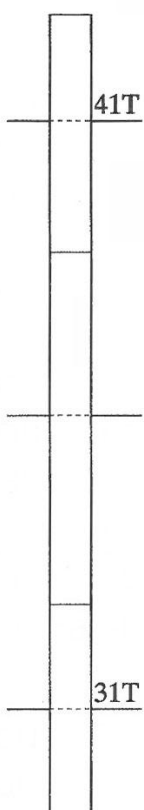
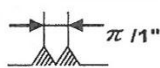

For Swing 16" , 18" , 20" (410mm, 460mm, 510mm) Series while Metric Leadscrew

 <p>70T</p> <p>50T</p>	 <p style="text-align: center;">LEAD SCREW-P=6mm</p> <p style="text-align: center;">R</p>							
	56	PAD10	32	PAD1	18	PAE2	9 1/2	PAF3
	54	PAD9	28	PAE10	16	PAE1	9	PAF2
	52	PAD8	27	PAE9	14	PAF10	8	PAF1
	48	PAD7	26	PAE8	13 1/2	PAF9	7	PBF10
	46	PAD6	24	PAE7	13	PAF8	6	PBF7
	44	PAD5	23	PAE6	12	PAF7	5 1/2	PBF5
	40	PAD4	22	PAE5	11 1/2	PAF6	5	PBF4
	38	PAD3	20	PAE4	11	PAF5	4 1/2	PBF2
	36	PAD2	19	PAE3	10	PAF4	4	PBF1
 <p style="text-align: center;">LEAD SCREW-P=6mm</p> <p style="text-align: center;">C</p>								
0.5	PSF1	1.75	PSE10	3.5	PSD10	6	PUD7	
0.75	PSF7	2	PSD1	4	PUD1	7	PUD10	
1	PSE1	2.25	PSD2	4.5	PUD2			
1.25	PSE4	2.5	PSD4	5	PUD4			
1.5	PSE7	3	PSD7	5.5	PUD5			

For Swing 16" , 18" , 20" (410mm, 460mm, 510mm) Series while Imperial Leadscrew

									LEAD SCREW – 4TPI						
	R														
	56	PAD10	32	PAD1	18	PAE2	9 1/2	PAF3							
	54	PAD9	28	PAE10	16	PAE1	9	PAF2							
	52	PAD8	27	PAE9	14	PAF10	8	PAF1							
	48	PAD7	26	PAE8	13 1/2	PAF9	7	PBF10							
	46	PAD6	24	PAE7	13	PAF8	6	PBF7							
	44	PAD5	23	PAE6	12	PAF7	5 1/2	PBF5							
	40	PAD4	22	PAE5	11 1/2	PAF6	5	PBF4							
	38	PAD3	20	PAE4	11	PAF5	4 1/2	PBF2							
36	PAD2	19	PAE3	10	PAF4	4	PBF1								
												LEAD SCREW – 4TPI			
C															
0.5	PSF1	1.75	PSE10	3.5	PSD10	6	PUD7								
0.75	PSF7	2	PSD1	4	PUD1	7	PUD10								
1	PSE1	2.25	PSD2	4.5	PUD2										
1.25	PSE4	2.5	PSD4	5	PUD4										
1.5	PSE7	3	PSD7	5.5	PUD5										

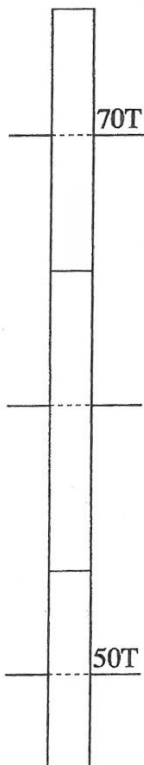
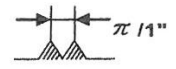
For Swing 22" , 26" (560mm, 660mm) Series while Metric Leadscrew

									LEAD SCREW-P=6mm							
	R															
	56	KAD10	27	KAE9	13	KAF8	5	KBF4								
	54	KAD9	26	KAE8	12	KAF7	4 1/2	KBF2								
	52	KAD8	24	KAE7	11 1/2	KAF6	4	KBF1								
	48	KAD7	23	KAE6	11	KAF5	3 1/2	JBF10								
	46	KAD6	22	KAE5	10	KAF4	3 1/4	JBF8								
	44	KAD5	20	KAE4	9 1/2	KAF3	3	JBF7								
	40	KAD4	19	KAE3	9	KAF2	2 7/8	JBF6								
	38	KAD3	18	KAE2	8	KAF1	2 3/4	JBF5								
	36	KAD2	16	KAE1	7	KBF10	2 1/2	JBF4								
	32	KAD1	14	KAF10	6	KBF7	2 1/4	JBF2								
	28	KAE10	13 1/2	KAF9	5 1/2	KBF5	2	JBF1								
																
	C															
	0.5	KSF1	2	KSD1	4.5	KUD2	9	JUD2								
	0.75	KSF7	2.25	KSD2	5	KUD4	10	JUD4								
	1	KSE1	2.5	KSD4	5.5	KUD5	11	JUD5								
	1.25	KSE4	3	KSD7	6	KUD7	12	JUD7								
	1.5	KSE7	3.5	KSD10	7	KUD10	13	JUD8								
1.75	KSE10	4	KUD1	8	JUD1	14	JUD10									

For Swing 22" , 26" (560mm, 660mm) Series while Imperial Leadscrew

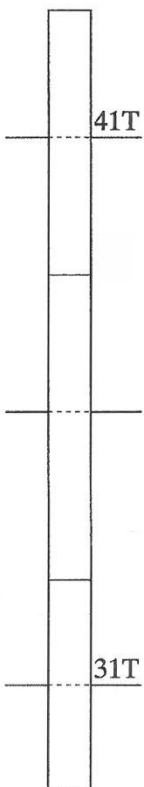
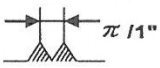
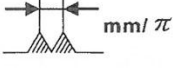
	 LEAD SCREW – 4TPI							
	R							
	56	KAD10	27	KAE9	13	KAF8	5	KBF4
	54	KAD9	26	KAE8	12	KAF7	4 1/2	KBF2
	52	KAD8	24	KAE7	11 1/2	KAF6	4	KBF1
	48	KAD7	23	KAE6	11	KAF5	3 1/2	JBF10
	46	KAD6	22	KAE5	10	KAF4	3 1/4	JBF8
	44	KAD5	20	KAE4	9 1/2	KAF3	3	JBF7
	40	KAD4	19	KAE3	9	KAF2	2 7/8	JBF6
	38	KAD3	18	KAE2	8	KAF1	2 3/4	JBF5
	36	KAD2	16	KAE1	7	KBF10	2 1/2	JBF4
	32	KAD1	14	KAF10	6	KBF7	2 1/4	JBF2
	28	KAE10	13 1/2	KAF9	5 1/2	KBF5	2	JBF1
	 LEAD SCREW – 4TPI							
	C							
	0.5	KSF1	2	KSD1	4.5	KUD2	9	JUD2
	0.75	KSF7	2.25	KSD2	5	KUD4	10	JUD4
	1	KSE1	2.5	KSD4	5.5	KUD5	11	JUD5
	1.25	KSE4	3	KSD7	6	KUD7	12	JUD7
	1.5	KSE7	3.5	KSD10	7	KUD10	13	JUD8
1.75	KSE10	4	KUD1	8	JUD1	14	JUD10	

6. LUBRICATION

6-1 Headstock Lubrication

Headstock lubrication is splash injection type. Oil grooves are equipped around the headstock to provide lubricant flowing from oil grooves to spindle, then finally reach the bottom of the headstock. To add oil, take off the oil plug on the top of the headstock cover, fill to the centerline of oil sight glass. Oil drain hole is located on the right bottom side of the headstock. Before operating the lathe, be sure the headstock is filled with oil. If not, add Shell Tellus #32. Exchange oil after one month use for the first time. Thereafter every two months.

6-2 Gear Box & Apron Lubrication

1. The gearbox is a reservoir oil bath type. To ensure the long service life of the gearbox and bedways, change the oil every six months.
2. The apron is also a reservoir oil bath type. Add oil as soon as the oil is lower than the centerline of the sight glass.

6-3 Lubrication Charts

No.	Location	Methods	Quantity	Oil time	Exchange time
1	Headstock	Loosen the oil input hole screw on the left top side of the headstock cover	L	Once per month	One month at the beginning, there after once two months.
2	Gear Box	Open the top cover and loosen the oil input hole screw	L	Once per month	Every six month
3	Apron	Loosen the oil input hole screw	L	Once per month	
4	Compound rest	Add oil with oil can	As required	Once per month	
5	Auto Feeding rod	Add oil with oil can	As required	Once per month	
6	Tailstock	Add oil with oil can	As required	Once per month	
7	Leadscrew	Add oil with oil can	As required	Once per month	
8	Bedway	Press the manual oil pump	As required	Once per month	

7. MAINTENANCE & ADJUSTMENT

7-1 Headstock

1. Headstock cover leaks:

When the headstock cover is removed it is important to re-Install it properly to prevent leakage. To re-install, the connecting surfaces must be cleaned and coated with a thin layer of grease so it will seal properly.

2. There are three possible causes for oil to leak from the spindle covers.

1. Reservoir over filled. (Correction: drain oil to proper level).
2. Wrong weight oil (Correction: Change to recommended lubricant)
3. Blocked oil return.(Correction: Remove the headstock cover and while turning the spindle blow air through the small oil holes located in the top of the head.

3. Spindle bearing adjustment:

The front and center bearings on the spindle are precision taper roller type. To maintain the accuracy and proper operation, the bearings must have the proper preload. To adjust the bearings loosen the set screws on locking nut ③ (Fig. 7-1-3) and tighten locking nut ④ to get the proper preload do not over tighten. After adjusting be sure to re-tighten the setscrews.

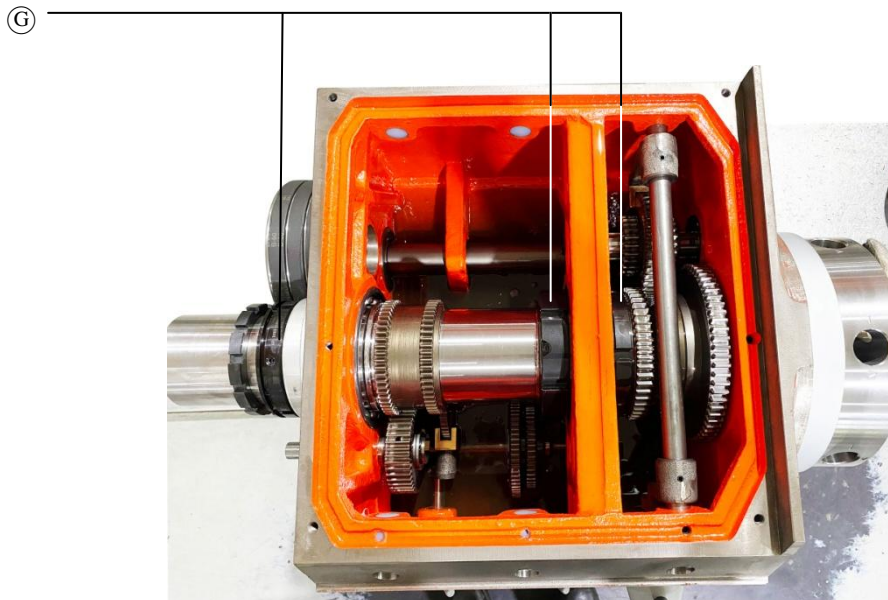

Fig.7-1.3

7-2 Apron & Saddle

1. The oil inlet is located on the right top side of the saddle base. (Plug marked "OIL")
2. The apron oil drain is located on the bottom of the apron. (See drawing)
3. Recommended lubricant is Shell Tellus No. 220 and changed every 6 months
4. Half nut adjustment: First remove the thread dial indicator, then find the 4 gib strip adjusting screw and loosen slightly. While pressing down on the half nut engagement lever adjust gib as needed. Re-tighten screw and replace the thread dial indicator.
5. If the manual oil pump fails it may need to be cleaned or repaired. To remove the pump, remove the pump body and loosen the plug lever to dismantle the unit. Use air to blow out the line. If the oil flow is too low the O-ring may need replacing. After replacing the O-ring, re-install pump and test.
6. The cone clutch in the center of the apron is an overload device. The safety overload weight limitation is 12Kg. This can be adjusted using the hexagon screw, located in the center of the apron. Turning the screw clockwise will increase the tension, counter clockwise will decrease the tension. This devise should automatically slip out if the overload is over 12Kg. When the auto-feed is engaged (Fig. 7-2.6) and the handwheel is held.

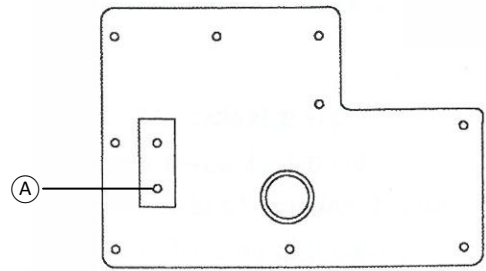

Fig.7-2.6

7-3 Gear Box

1. The oil inlet for the gearbox is located under the cover on top of the gear box. (See Fig. 7-3Ⓐ)
2. The drain is located on the left bottom side of the gear box near the 10 step feed selection dial as shown by arrow Ⓑ Fig. 7-3.
3. Recommended lubricant is Shell Tellus No. 220 and should be changed every 6 months.

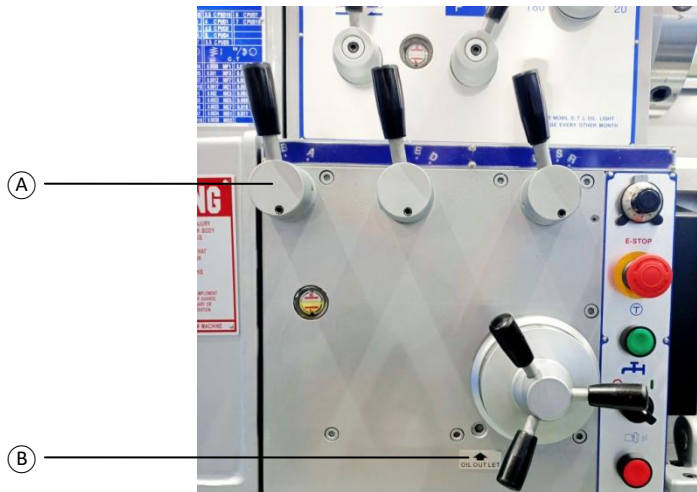

Fig.7-3

7-4 Tailstock Adjustment

1. Unclamp the tailstock - clamping lever.
2. Loosen the 2 hexagon head screws. (one on each side of tailstock)
3. Using a test bar between dead centers, make necessary adjustments using the slotted adjusting screws. (one on each side).
4. After adjusting re-tighten the two hexagon head screws and re-check for alignment.

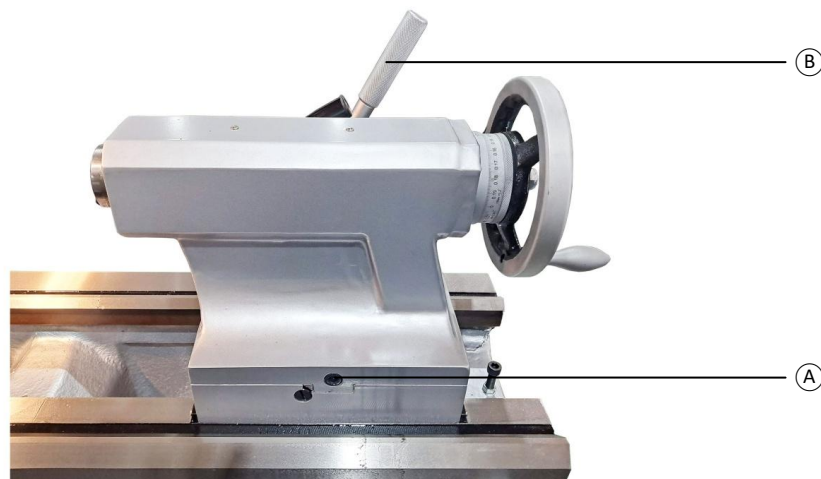
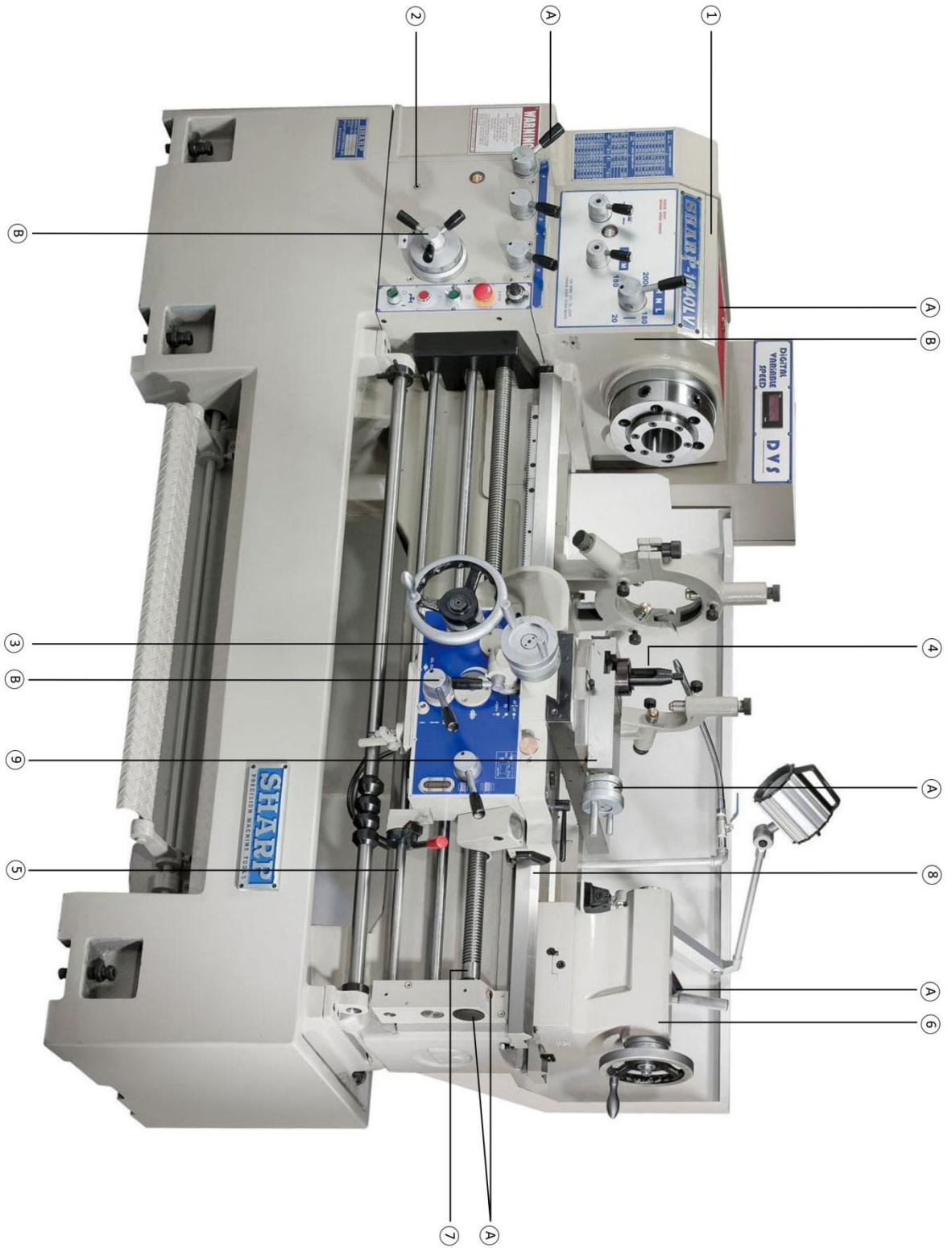

Fig.7-4

7-4 Lubrication Location

A: Oil input hole

B: Oil drain hole



7-5 Belt Tension Adjustment

After prolonged use, the belt will stretch and require periodic adjustment. To adjust belts:

1. Take off the cover on the left back side of the lathe.
2. Loosen adjusting lock nut ① Fig. 7-5 and adjust belt to proper tension.
3. After adjustment is made, re-tighten lock nut and replace the cover.

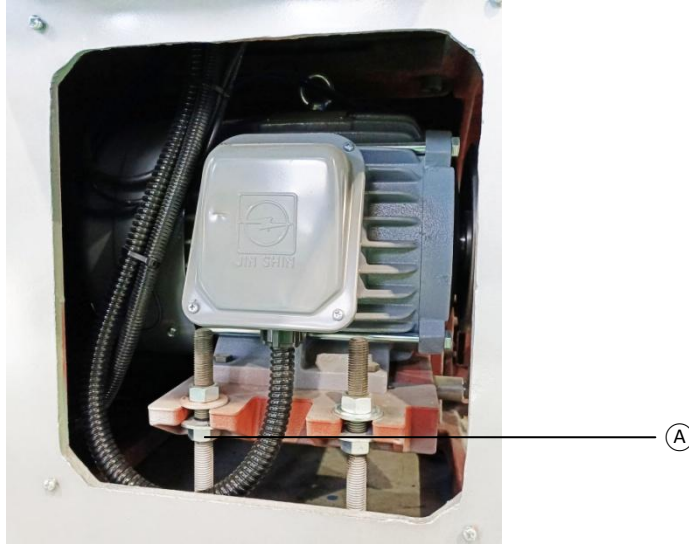

Fig.7-5

7-6 Brake Belt Adjustment

If the brake belt becomes worn or loose nut ② Fig. 7-6 on the brake band must be adjusted. This can be done by:

1. Remove the side rear cover.
2. Loosen the nuts on the top and tighten the nuts on the bottom to the appropriate height.
3. Re-tighten the top nuts and replace the cover.



Fig.7-6

7-7 Brake & Micro Switch Adjustment

The foot brake is connected with the micro switch. There should be 0-1 mm end play between the brake arm and the head of the micro switch. (See Fig. 7-7). The proper function of the brake is to first, cut off the power and then engage the brake belt. After using the brake, it is necessary to use the control lever to re-start the lathe.

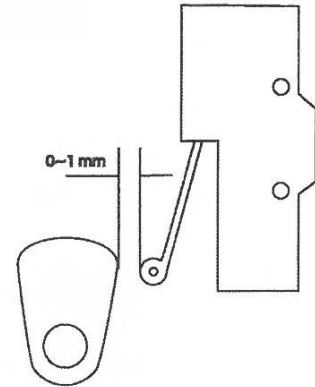

Fig. 7-7

7-8 Leadscrew Backlash Adjustment

Should the threading not repeat, the cause is most likely the leadscrew backlash. To adjust the backlash, remove the plastic cover on the leadscrew bracket (Fig. 7-8), loosen nut (A) then tighten the left side nut (B). To check the backlash, engage the half nut and while observing the connecting section of the leadscrew to the gearbox move the apron handwheel back and forth. If the backlash is properly set there should be no movement in the shaft. After adjusting, re-tighten nut (A) and replace plastic cover.

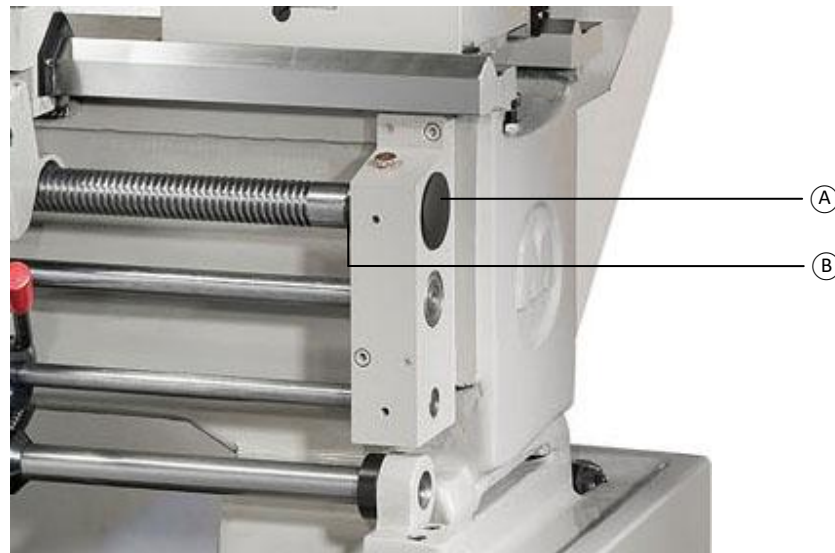

Fig. 7-8

7-9 Coolant Pump

Problem : No coolant flow :

Solution :

1. Make sure the switch is on.
2. Check if the pump motor is working.
3. Check if coolant level.
4. If all the above are normal, change the pump.

8. TAPER ATTACHMENT

Installation Taper Attachment:

STEP1:

Install taper attachment on the carriage using screws No.③① via hole ④A

(Do not tighten too tight using screw M10x40L and flat washer.)

STEP2:

Disengaged screw No.⑧

STEP3:

Adjust the position of No.① and let are gage point is contacted with

No.206009.

STEP4:

Set a dial gage on the No.⑨, and gage point is contacted the surface of bed.

Moving No.⑨ pointer has to be constant lifting it's nut, adjusting the position of No.①.

STEP5:

Disengaged screw No.206010 then locked No.206009 to No.⑦

STEP6:

Replaced screw No.⑧

STEP7:

Drill B hole. (Using Ø 6mm drilling tool)

STEP8:

Set straight pin. (Ø 6x45L)

STEP9:

Install universal connected-rod.

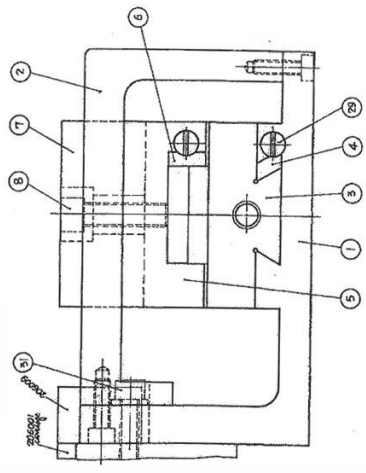
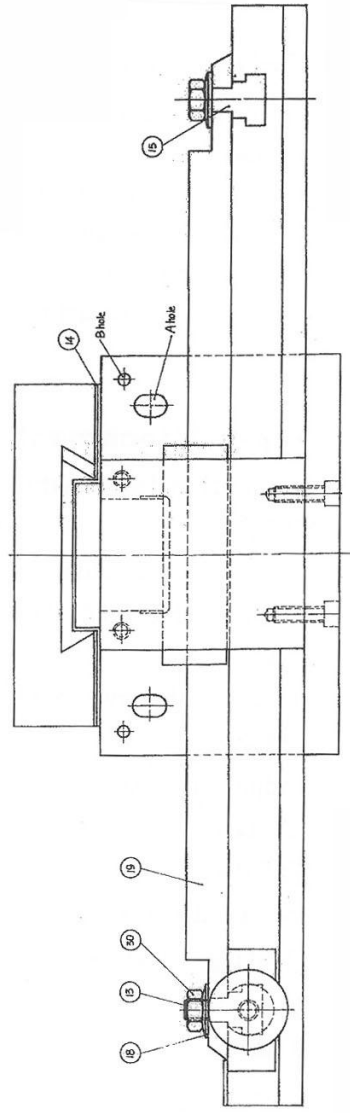
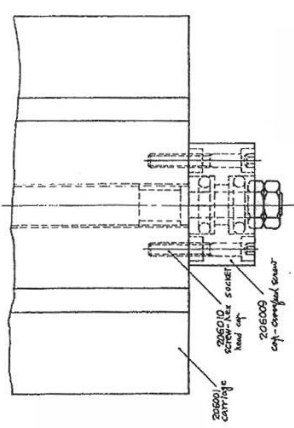
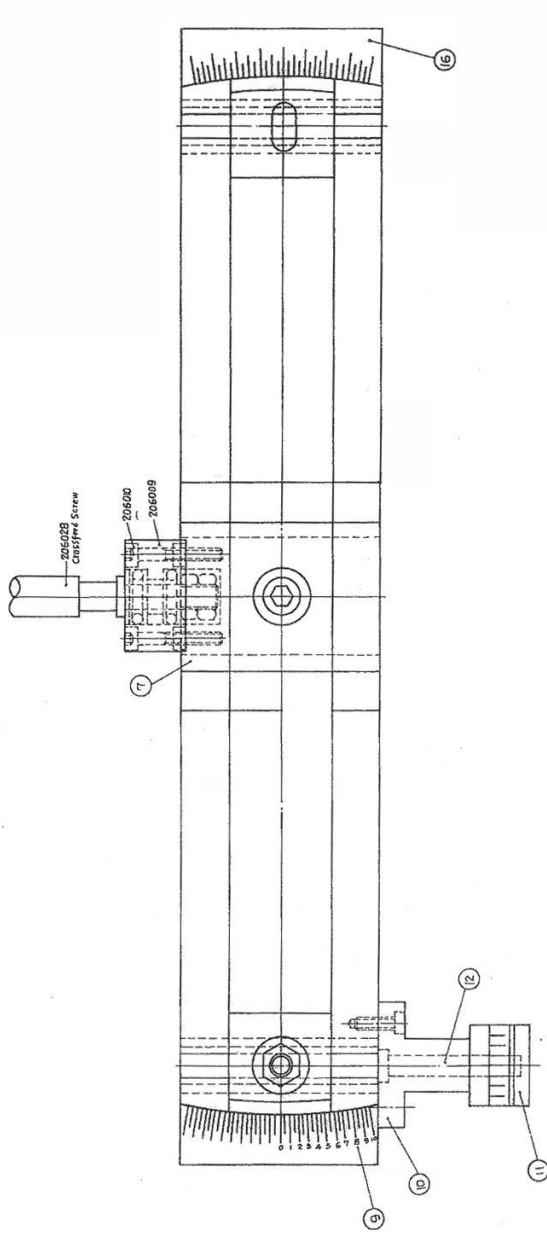

TROUBLESHOOTING

The objective is to locate and isolate the problem

NOISE IN HEADSTOCK/GEARBOX:

Note: 85 % of noise normally comes from the output shaft pulley.

1. Run lathe with all controls in neutral to see if the problem is in the spindle.
 - a. If the problem is in the spindle and the finish is good, the source is most likely in the rear bearing (Part#65). However if the finish is poor, the problem could be the front bearings are either loose or damaged.
 - b. If the problem is not in the spindle, continue by engaging one control at a time until the problem is found. **(Figure 1)**
 - c. If the problem is not in the headstock. Before you continue to the gearbox, check the change gears located on the back of the headstock for proper backlash and alignment. **(Figure 2)** If these gears are found to be in good working order, perform the same sequence as above on the gearbox. (engage one control) at a time until the problem is located. **(Figure 3)**
 - d. Once you determine the problem is either in the gearbox or the headstock, that part of the machine must be opened up to inspect for possible worn or broken parts.
2. If the gearbox is in order and the feed or leadscrews are not turning check the shear pins. (There are two shear pins on each shaft). **(Figure 4)**

Notes:



Figure 2

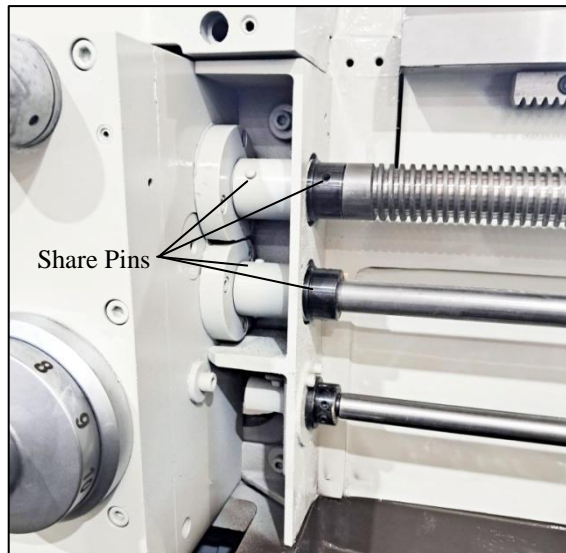
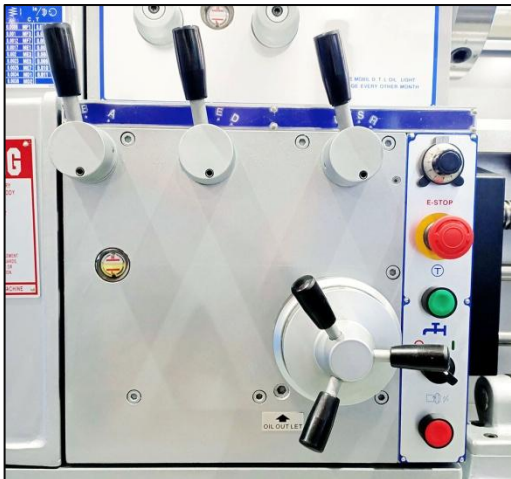

Figure 4

THREADING PROBLEMS:

Should there be a problem cutting **standard threads:**

- a. Check the chasing dial to see if it is loose from shaft.
- b. Check gear at bottom of shaft for tightness & proper fit against the lead screw.
- c. Check the half nut for proper fit.

Note: All Sharp Lathes are made to cut ASE (Inch) threads. To cut metric threads, make sure the half nuts are engaged at all times, because it is not a metric based machine, and therefore will not repeat according to the threading dials.

Notes:

CHATTER/VIBRATION PROBLEMS:

1. Spindle has excessive run out. **(Figure 5)**
2. Loose Compound, cross feed or saddle. **(Figure 6)**
3. Loose motor mount or motor not seated properly on base. **(Figure 7)**
4. Backlash on drive pulley shaft and key. **(Figure 2)**
5. New rack and old gear. (If machine has been crashed) **(Figure 8)**
6. Irregular power supply. (Not getting 3-phase)
7. Leveling bolts loose or lathe not properly leveled.
8. Defective live center. (On a long work piece chatter in the center & not on ends).

COOLANT PUMP NOT WORKING OR PRESSURE TOO LOW.

- a. Check coolant level.
- b. Check pump shaft for rotation. (Proper rotation is clockwise).
- c. Check for clogged line. (Both suction and discharge).

Notes:

ADJUSTMENTS AND REPAIRS:

ADJUSTING LEAD SCREW BACKLASH

- a. Remove plastic cover on the lead screw bracket.
- b. Loosen lock nut “A” under cover.
- c. Tighten left side nut “B” until backlash has been removed.
- d. Re-tighten lock nut “A” and replace plastic cover. (**Figure 9**)

ADJUSTING SPINDLE BEARINGS

The front and middle spindle bearings are **precision taper roller bearings**. To adjust:

- a. Loosen set screw (Part #60) on locking NUT (Part #62).
- b. Tighten locking nut (Part #62) to obtain proper preload. (Check by spinning chuck by hand. Chuck should rotate freely for at least 2 revolutions).
- c. Re-tighten set screw (Part #60) on lock nut. (**Figure 10**)

Notes:

ADJUSTING THE FEED OVERLOAD

This machine is equipped with a safety overload which can be adjusted by the set screw (Part # 73) located in the center of cover (Part # 75) which is located in the center of the apron. (To increase tension turn clockwise, to reduce tension turn counterclockwise). **(Figure 13)**

ADJUSTING HALF NUTS

1. Remove chasing dial assembly
 2. Loosen 3 screws
 3. Adjust half nuts and re-tighten the 3 screws
 4. Test movement before reassembling.
- (Figure 17)**

Notes:

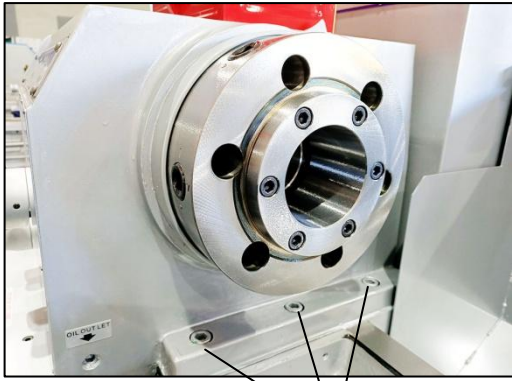

Figure 5

Loosen bolts a bit when aligning Head.



Figure 6



Figure 7



Figure 2

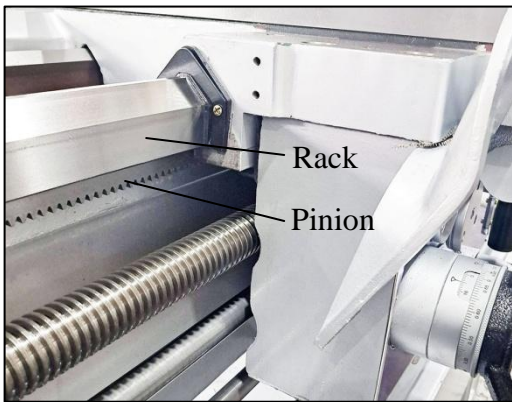

Figure 8

Rack

Pinion

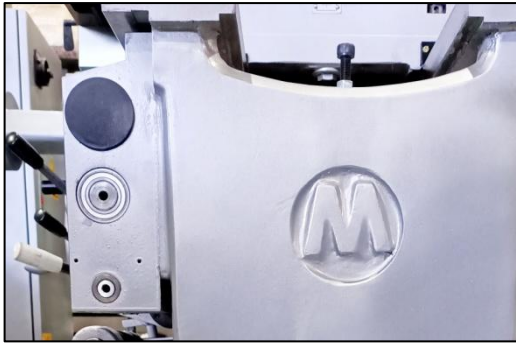

Figure 9



Figure 10

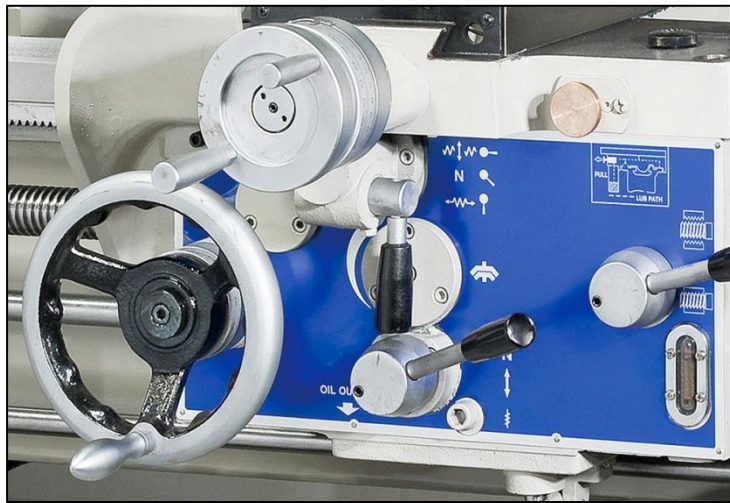
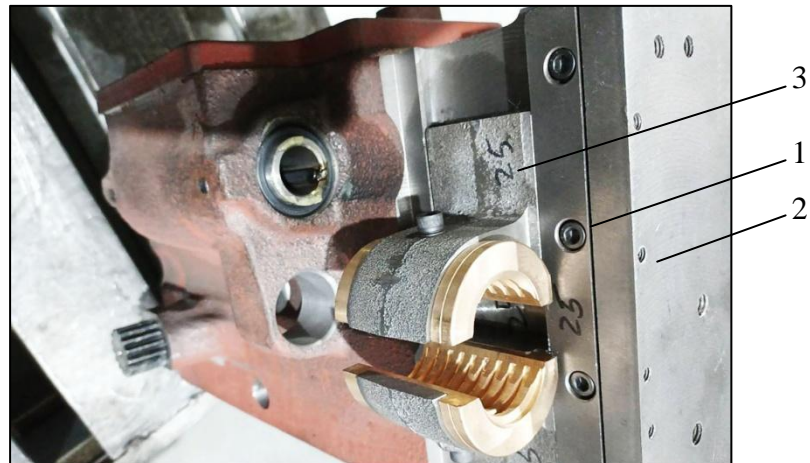

Figure 13



1. Loosen 3 screws
2. Tighten 3 screws on the side as needed
(First take off chasing dial assembly.)
3. Make sure to test the up/down movement of
halfnuts/holders before reassembling

Figure 17

OIL LEAKS

Headstock top cover leak: Remove cover, clean all surfaces with a clean rag, apply a small coat of *grease* on the gasket surface and reinstall the cover.

Oil leak around the spindle is most likely caused by the oil level being too high or oil return hole over the spindle being blocked or restricted. Most of the time this oil inlet hole can be cleaned out by simply blowing air through the passage. **(Figure 10)**

****Note:* Make sure to use 10W Oil only! Higher viscosity will result in leak!

Oil leak at the rear of spindle:

1. Mark lock nut and spindle. **(Figure 11)**
2. Mark balance weights on lock nut **(Figure 11)**
3. Remove lock nut. (First remove set screw)
4. Remove cover
5. Clear oil return hole using air pressure. **(Figure 12)**

Note: Be sure cover is not obstructing return.

ALIGNING THE HEAD

A taper will most likely be created by the head being out of alignment. To align head:

1. Loosen bolts on base of head slightly. (3 in front and 3 in back) **(Figure 5)**
2. Make appropriate adjustment to correct problem.
 - a. "C" Model adjusting screws are in front of lathe.
 - b. "S" and "F" Models adjusting screws are in the back of the lathe.

Notes:

APRON REMOVAL

1. Remove dowel pins from lead screw and feed shaft (**Figure 4**)
2. Remove chasing dial assembly (**Figure 15**)
3. Remove rotation lever assembly (**Figure 15**)
4. Remove lead screw bracket and slide lead screw & lead shafts out of apron (**Figure 16**)
5. Removing 4 bolts will allow the apron to be removed. (Caution should be taken when removing, due to its weight).

Notes:

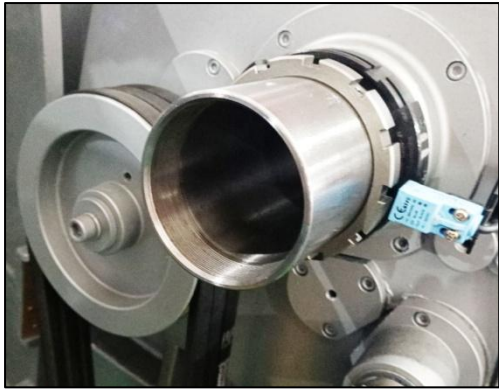

Figure 11

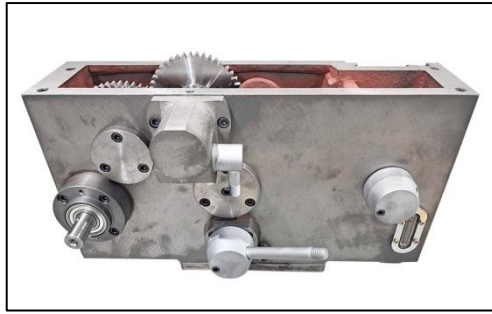

Figure 12

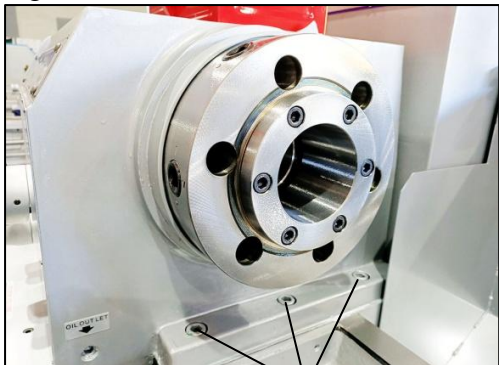

Figure 5
Loosen bolts a bit when aligning Head.

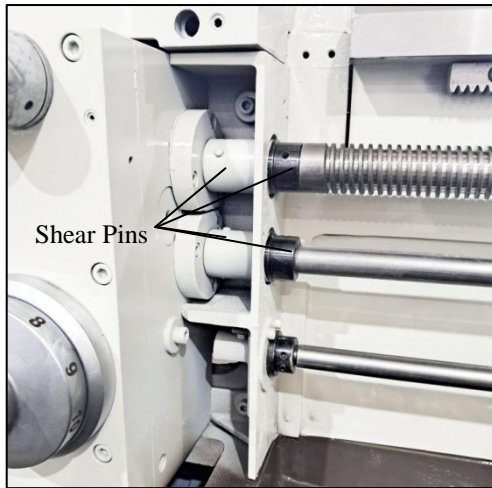

Figure 4



Figure 10

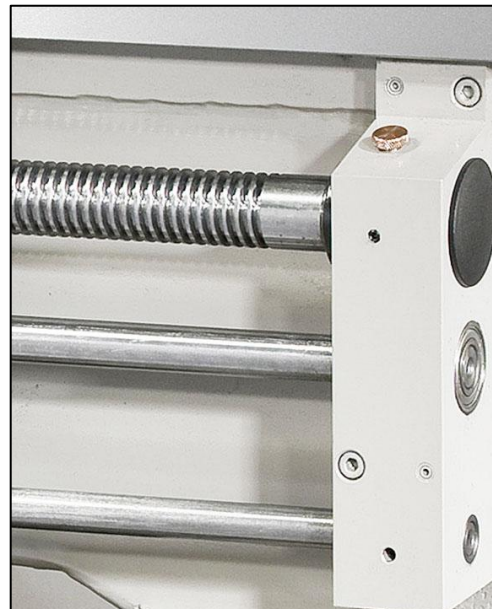

Figure 16

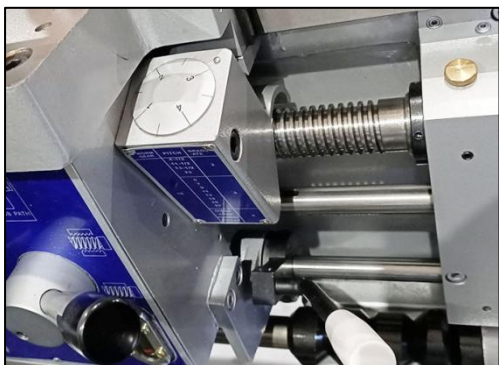
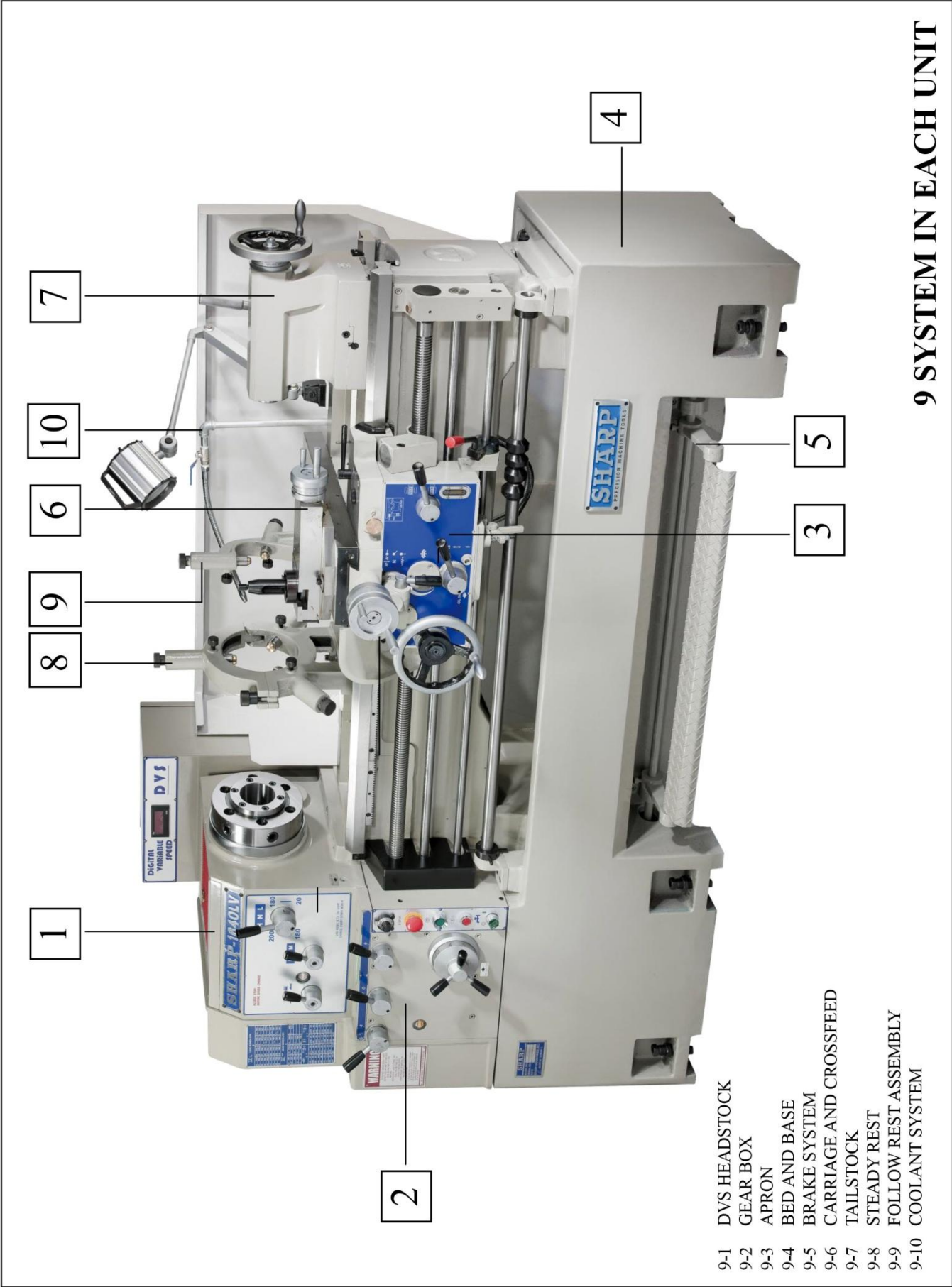

Figure 15

CONTENTS

9	SYSTEM IN EACH UNIT.....	1
9.1	DVS HEADSTOCK.....	2
9.2	GEAR BOX.....	6
9.3	APRON.....	11
9.4	BED AND BASE	16
9.5	BRAKE SYSTEM.....	19
9.6	CARRIAGE AND CROSSFEED.....	21
9.7	TAILSTOCK	25
9.8	STEADY	27
9.9	FOLLOW REST ASSEMBLY	29
9.10	COLLANT SYSTEM ASSEMBLY	31



- 9-1 DVS HEADSTOCK
- 9-2 GEAR BOX
- 9-3 APRON
- 9-4 BED AND BASE
- 9-5 BRAKE SYSTEM
- 9-6 CARRIAGE AND CROSSFEED
- 9-7 TAILSTOCK
- 9-8 STEADY REST
- 9-9 FOLLOW REST ASSEMBLY
- 9-10 COOLANT SYSTEM

9 SYSTEM IN EACH UNIT

9-1 DVS HEADSTOCK S DVS MODE-202207

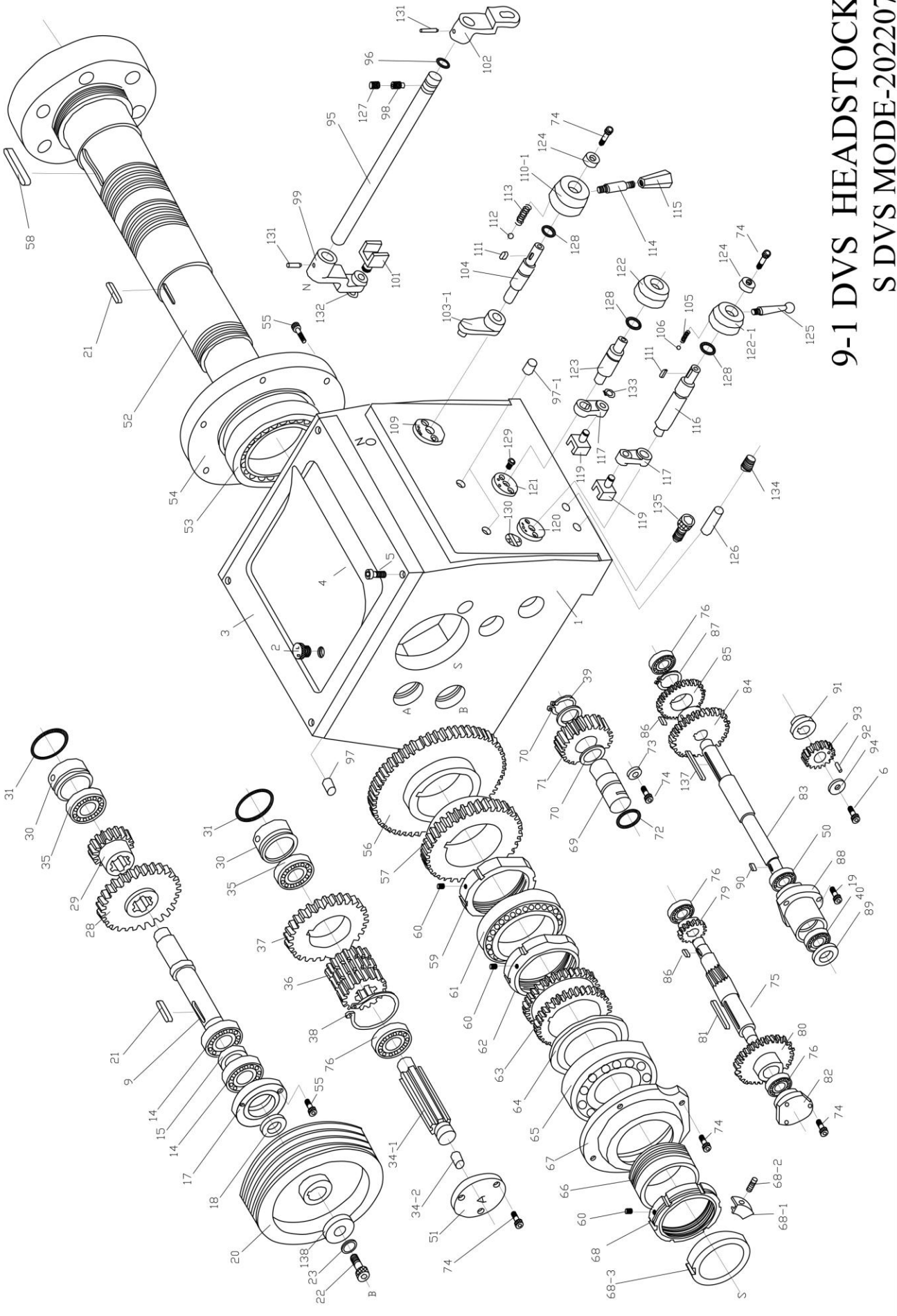

DVS HEADSTOCK ASSMBLY (Spindle Bore : 80mm or 3")

Item No.	Part Name	Amt. Used	Type: 16 Part No.	Type: 18 Part No.
1	Head stock	1	3001001-173	3001001-193
2	Oil plug	1	1122103405	1122103405
3	Head stock cover	1	1120200509	1120200509
4	Blanket	1	1003501701	1003501701
5	Hexagon socket screw, M8xP1.25x35L	4	91110835	91110835
6	Hexagon socket screw, M8xP1.25x25L	1	91110825	9110825
9	Input-shaft	1	112020880	112020880
14	Ball bearing , 6206	2	91301021	91301021
15	Collar	1	1120206501	1120206501
17	Housing	1	1120206903	1120206903
18	Oil-seal , TC30x50x8	1	91523001	91523001
19	Hexagon socket screw, M6xP1.0x25L	6		
20	Pulley	1	1120206305	1220200305
21	Square key , 8x7x45L	2		
22	Hexagon socket screw, M12xP1.75x30L	1	91111230	91111230
23	Spring washer , 12	1		
28	Gear-k	1	1120201202	1120201202
29	Gear-o	1	3001029-001	3001029-001
30	Plug-cover	2	1120202905	1120202905
31	O-ring , P55x3.5	2	9151P055	9151P055
34-1	Shaft-L	1	1120208505	1120208505
34-2	Plug	1	112020940	112020940
35	Ball bearing , 6305	2	91301029	91301029
36	Gear-l	1	1120201408	1120201408
37	Gear-m	1	3001037-001	3001037-001
38	Snap ring , S65	2		
39	Snap ring , S30	1	9171S030	9171S030
40	Ball bearing , 6005	3	91301010	91301010
50	Ball bearing , 6205	2	91301020	91301020
51	Cover	1	1120203108	1120203108
52	Spindle (A2-8)	1	3001052-A03	3001052-A03
	(D1-8)	1	3001052-D03	3001052-D03
53	Taper roller bearing, 32922	1		
54	Cover	1	3001054-003	3001054-003
55	Hexagon socket screw, M6xP1.0x35L	6	91110635	91110635
56	Gear-p	1	3001056-001	3001056-001
57	Gear-n	1	3001057-001	3001057-001
58	Square key , 8x7x85L	1	91620806	91620806
59	Lock-nut	1	122020170	122020170
60	Set screw, M8xP1.25x8L	5	91120808	91120808

DVS HEADSTOCK ASSMBLY (Spindle Bore : 80mm or 3")

Item No.	Part Name	Amt. Used	Type: 16 Part No.	Type: 18 Part No.
61	Taper roller bearing, 32920	1		
62	Lock-nut	1	9124F100	9124F100
63	Gear	1	3001063-001	3001063-001
64	Collar	1	3001064-001	3001064-001
65	Ball bearing , 6018	1		
66	Oil return collar	1	3001066-001	3001066-001
67	Cover	1	1120203608	1120203608
68	Lock-nut	1	122020180	122020180
68-1	Balance piece	2	3001068-003	3001068-003
68-2	Set screw, M5x8	4	1120207008	1120207008
68-3	Touch collar	1	3001068-004	3001068-004
69	Idle gear shaft	1	1120207508	1120207508
70	Spacer	2	1120206609	1120206609
71	Idle gear	1	1120202003	1120202003
72	O-ring , P29	1	9151P029	9151P029
73	Washer	1	1120207606	1120207606
74	Hexagon socket screw, M6xP1.0x16L	16	91110616	91110616
75	Gear shaft-C	1	1120202101	1120202101
76	Ball bearing , 6204	5	91301018	91301018
79	Gear	1	1120202209	1120202209
80	Gear	1	3001080-001	3001080-001
81	Square key , 6x6x65L	1		
82	Cover	1	1120203902	1120203902
83	Shaft-D	1	3001083-001	3001083-001
84	Gear	1	1120202405	1120202405
85	Gear	1	1320200601	1320200601
86	Square key , 6x6x18L	2	91610604	91610604
87	Snap ring , S40	1	9171S040	9171S040
88	Housing	1	1120204007	1120204007
89	Oil-seal , TC25x47x8L	1	91522501	91522501
90	Square key , 6x6x12L	1	91610601	91610601
91	Collar	1	1121602203	1121602203
92	Taper pin ,0#25L	1	82010025	82010025
93	Gear (24T in)	1	1121600405	1121600405
	Gear (41T mm)	1	1121600307	1121600307
94	Washer	1		
95	Shifting shaft	1	3001095-001	3001095-001
96	O-ring , P16	6	9151P016	9151P016
97	Plug	3	1120207704	1120207704
97-1	Plug	2	3001097-002	3001097-002
98	Set screw	3	1120204203	1120204203
99	Shifting lever	3	1120204301	1120204301

DVS HEADSTOCK ASSMBLY (Spindle Bore : 80mm or 3")

Item No.	Part Name	Amt. Used	Type: 16 Part No.	Type: 18 Part No.
101	Shifting fork	1	1120204409	1120204409
102	Shifting lever	1	1120204507	1120204507
103-1	Shifting lever	1	1120204703	1120204703
104	Shaft	1	1120204801	1120204801
105	Spring , D6xd0.8x25L	2	91901060102902	91901060102902
106	Ball steel , Ø 1/4"	2		
109	Detent plate	1	1120205102	1120205102
110-1	Hub	1	1120205308	1120205308
111	Square key , 5x5x15L	2	91610501	91610501
112	Ball steel , Ø5/16"	1		
113	Spring , D8xd0.8x25L	1		
114	Lever	1	1120207302	1120207302
115	Knob	3	1120207400	1120207400
116	Shaft	1	1120208309	1120208309
117	Shifting lever	2	1120205504	1120205504
118	Shifting fork	1	1120208005	1120208005
119	Shifting fork	1	3001119-001	3001119-001
119-1	Shifting fork	1	112020561	112020561
120	Detent plate	1	1120205700	1120205700
121	Detent plate	1	1120205808	1120205808
122	Knob	1	1120205906	1120205906
122-1	Knob	1	1120206001	1120206001
123	Shaft	1	1220200403	1220200403
124	Washer	5	1120206109	1120206109
125	Lever	2	1120207204	1120207204
126	Pin	2	1121600709	1121600709
127	Set screw , M8xP1.25x10L	3	91120810	91120810
128	O-ring , P18xP1.0x14L	5		
129	Screw , M6xP1.0x14L	10	91160614	91160614
130	Lenz-oil , Ø 29	1	93902003000004	93902003000004
131	Spring pin , Ø 5x32L	9		
	Spring pin , Ø 5x26L	2	92030526	92030526
132	Snap ring , S12	3	9171S012	9171S012
133	Snap ring , S10	2		
134	Set screw, M10xP1.25x20L	2	91121020	91121020
135	Hexagon socket screw, M10xP1.5x95L	2	91111095	91111095
136	Hexagon socket screw, M6xP1.0x40L	4	91110640	91110640
137	Square key , 6x6x70L	1	91610608	91610608
138	Spacer , D40x8L	1	1120206403	1120206403

9-2 GEAR BOX

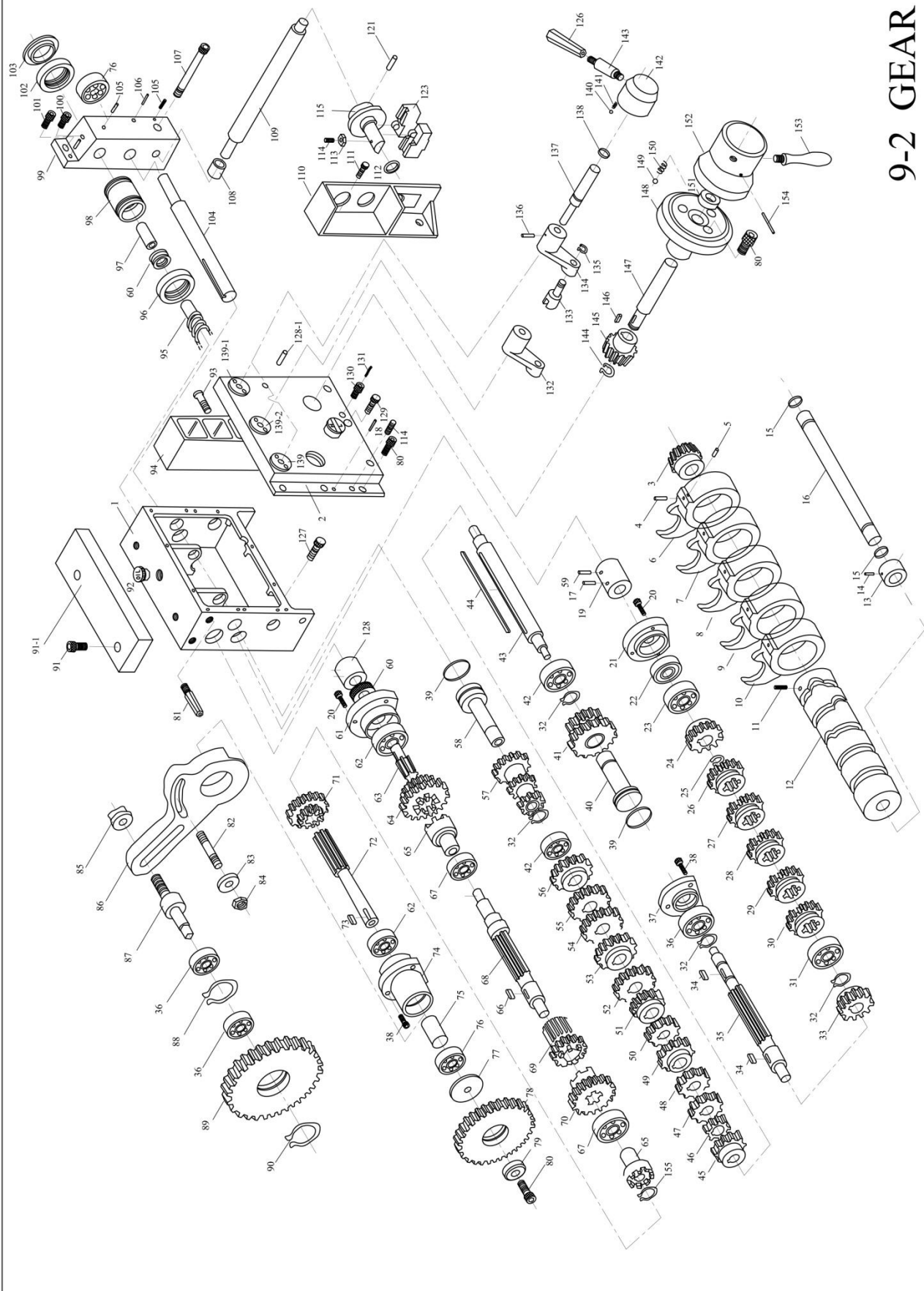

GEAR BOX ASSEMBLY

Item No.	Part Name	Amt. Used	Type: 16 Part No.	Type: 18 Part No.
1	Gear box	1	1210300307	1210300307
2	Cover-gear box	1	1210300101	1210300101
3	Gear-driven bevel	1	1210300405	1210300405
4	Pin-fixed	5	1210300503	1210300503
5	Pin-split	5	92004000000014	92004000000014
6	Claw-shifter	1	1210300601	1210300601
7	Claw-shifter	1	1210300709	1210300709
8	Claw-shifter	1	1210300807	1210300807
9	Claw-shifter	1	1210300905	1210300905
10	Claw-shifter	1	1210301000	1210301000
11	Screw-hexa. socket headless set , M8xP1.25x8L	1	1210301108	1210301108
12	Cam-shifter	1	1210301206	1210301206
13	Collar	1	1210301304	1210301304
14	Screw set, M8x12	2	9111008012	9111008012
15	Ring-"O" , P18	2	9151P018	9151P018
16	Shaft-"A"	1	1210301402	1210301402
17	Pin-taper , 4x38	3	92010438	92010438
18	Pin-taper , 6x38	2	1210702301	1210702301
19	Collar-linkage	1	1210301500	1210301500
20	Screw-hexa. socket head cap, M6xP1.0x16L	6	91110616	91110616
21	Cap-right	1	1210301608	1210301608
22	Seal-oil, 20x40x10L	1	91522001	91522001
23	Bearing-ball , 6204	1	91301018	91301018
24	Gear-"B" shaft (36T)	1	1210301706	1210301706
25	Snap ring , S25	2	9171S025	9171S025
26	Gear-"B" shaft	1	1210301804	1210301804
27	Gear-"B" shaft	1	1210301902	1210301902
28	Gear-"B" shaft	1	1210302007	1210302007
29	Gear-"B" shaft	1	1210302105	1210302105
30	Gear-"B" shaft	1	1210302203	1210302203
31	Bearing-ball , 6004	1	91301006	91301006
32	Snap ring , S20	2	9171S020	9171S020
33	Gear-"B" shaft	1	1210302301	1210302301
34	Key-square , 6x6x20L	2	91610605	91610605
35	Shaft-"B"	1	1210302409	1210302409
36	Bearing-ball , 6003	3	91301005	91301005
37	Cap-left	1	1210302507	1210302507
38	Screw-hexa. socket head cap, M6xP1.0x12L	6	91110612	91110612
39	Ring-"O" , P36	2	9151P036	9151P036
40	Shaft-"C"	1	1210302605	1210302605
41	Gear-"C" shaft	1	1210302703	1210302703
42	Bearing , 6203	2	91301016	91301016
43	Shaft-"D"	1	1210302801	1210302801
44	Key-square , 6x6x146L	1		
45	Gear-"D" shaft	1	1210302909	1210302909

GEAR BOX ASSEMBLY

Item No.	Part Name	Amt. Used	Type: 16 Part No.	Type: 18 Part No.
46	Gear-"D" shaft	1	1210303004	1210303004
47	Gear-"D" shaft	1	1210303102	1210303102
48	Gear-"D" shaft	1	1210303200	1210303200
49	Gear-"D" shaft	1	1210303308	1210303308
50	Gear-"D" shaft	1	1210303406	1210303406
51	Gear-"D" shaft	1	1210303504	1210303504
52	Gear-"D" shaft	1	1210303602	1210303602
53	Gear-"D" shaft	1	1210303700	1210303700
54	Gear-"D" shaft	1	1210303808	1210303808
55	Gear-"D" shaft	1	1210303906	1210303906
56	Gear-"D" shaft	1	1210304001	1210304001
57	Gear-"E" shaft	1	1210304109	1210304109
58	Shaft-"E"	1	1210304207	1210304207
59	Pin-taper, 3x38	1	1003502904	1003502904
60	Bearing-thrust , 51104	2	91303003	91303003
61	Cap	1	1210304305	1210304305
62	Bearing-ball , 6004V	2	91301008	91301008
63	Shaft-"F"	1	1210304403	1210304403
64	Gear-"F" shaft	1	1210304501	1210304501
65	Shaft-"F" (left)	1		
	(right)	1		
66	Square key , 4x4x20L	2	91610401	91610401
67	Bearing ball, 6005	2	91301010	91301010
68	Shaft-"G"	1	1210304805	1210304805
69	Gear-"G" shaft	1	1210304903	1210304903
70	Gear-"G" shaft	1	1210305008	1210305008
71	Gear-"H" shaft	1	1210305106	1210305106
72	Shaft-"H"	1	1210300209	1210300209
73	Key-square , 6x6x13L	1	91610602	91610602
74	Cap-bearing	1	1210305204	1210305204
75	Bushing-"H" shaft	1	1210305302	1210305302
76	Bearing ball , 6004Z	1	91301007	91301007
77	Spacer	1	1121600905	1121600905
78	Gear-drive shaft (57T in)	1	1121600601	1121600601
	(92T mm)	1	1121600503	1121600503
79	Washer	1	1121602105	1121602105
80	Screw-hexa. socket head cap, M8xP1.25x16L	1	91110816	91110816
81	Bolt-lock end cover	1	1122100208	1122100208
82	Stud	1	1121601108	1121601108
83	Washer, 1/2	1	1121602301	1121602301
84	Nut, W16	1	91210016	91210016
85	Nut-lock stud	1	1121601706	1121601706
86	Quadrat	1	1121601000	1121601000
87	Stud-gear	1	1121601206	1121601206
88	Snap ring , R35	1	9171R035	9171R035

GEAR BOX ASSEMBLY

Item No.	Part Name	Amt. Used	Type: 16 Part No.	Type: 18 Part No.
89	Gear-quadrat (71T in)	1	1121600209	1121600209
	(84T mm)	1	1121600101	1121600101
90	Snap ring , S16	1		
91	Screw-hexa. socket head cap, M6xP1.0x25L	2	91110625	91110625
91-1	Cover	1	1222100200	1222100200
92	Plug-oil inlet	1	1122101401	1122101401
93	Screw-hexa. socket head cap, M6xP1.0x65L	2		
94	Seat-pilot light		121071206	121071206
95	Lead-screw (5 feet in)	1	1210700209	1210700209
	(5 feet mm)	1	1210700101	1210700101
	(6 feet in)	1	1220700202	1220700202
	(6 feet mm)	1	1220700104	1220700104
	(8 feet in)	1	1230700205	1230700205
	(8 feet mm)	1	1230700107	1230700107
	(10 feet in)	1	1240700208	1240700208
	(10 feet mm)	1	1240700100	1240700100
96	Nut-lock	1	1210700709	1210700709
97	Bushing-leadscrew	1		
98	Plug-leadscrew	1	1210700709	1210700709
99	Supporter-for leadscrew, feed rod	1	1210700807	1210700807
100	Screw-hexa. socket head cap, M8xP1.25x25L	1	1122101509	1122101509
101	Screw-hexa. socket head cap, M8xP1.25x30L	1	91110830	91110830
102	Nut-lock	1	1210700709	1210700709
103	Plug-plastic	1	1122101607	1122101607
104	Rod-feed	1	1210700307	1210700307
105	Screw-hexa. socket headless set, M6xP1.0x20L	2		
106	Pin-taper , 6x100L	1	1210700601	1210700601
107	Bolt-hexa. socket head cap, M8xP1.25x80L	1		
108	Bushing-spindle starting rod	1	1210700905	1210700905
109	Rod-spindle starting switch (5 feet)	1	1210700405	1210700405
	(6 feet)	1	1220700408	1220700408
	(8 feet)	1	1230700401	1230700401
	(10 feet)	1	1240700404	1240700404
110	Seat-switch	1	1210701304	1210701304
111	Screw-hexa. socket head cap , M8xP1.25x25L	2	91110825	91110825
112	Snap ring , S30	1	9171S030	9171S030
113	Nut, M6xP1.0	1	91210006	91210006
114	Screw-hexa. socket headless set , M6xP1.0x20L	1	1210305400	1210305400
115	Bracket	1	1210701402	1210701402
121	Pin , 5x25L	1	92030530	92030530

GEAR BOX ASSEMBLY

Item No.	Part Name	Amt. Used	Type: 16 Part No.	Type: 18 Part No.
122	Screw-hexa. socket headless set ,M6xP1.0x8L	1		
123	Switch	2		
126	Knob	3	1120207400	1120207400
127	Screw-hexa. socket head cap, M10xP1.5x35L	4	1210701500	1210701500
128	Pin-taper , 0x38	1	1003502904	1003502904
128-1	Pin-taper , 6x45	1	2251002303	2251002303
129	Screw-hexa. socket head cap, M8xP1.25x40L	7	91110840	91110840
130	Screw-taper, oil outlet, PT3/8	1		
131	Screw-set, taper, PT1/8	1		
132	Shifter	2	1210305606	1210305606
133	Shoe-shifter	3	1210305704	1210305704
134	Shifter	1	1210306005	1210306005
135	Snap ring , S10	3		
136	Pin-spring , 5x26	3	92030526	92030526
137	Shaft-shifter	3	1210306103	1210306103
138	Ring-"O" , P12	3	9151P012	9151P012
139	Detent Plate	1	1210306201	1210306201
139-1	Detent Plate	1	1210306309	1210306309
139-2	Detent Plate	1	1210306407	1210306407
140	Ball-steel , 1/4	3		
141	Spring , 5x26	3		
142	Hub	3	1210306505	1210306505
143	Lever	3	1210306701	1210306701
144	Snap ring , S15	1	9171S015	9171S015
145	Gear-drive bevel	1	1210306809	1210306809
146	Key-square , 5x5x15L	1		
147	Shaft-bevel gear	1	1210306907	1210306907
148	Seat-gear shifting	1	1210307002	1210307002
149	Ball-steel , 5/16	1		
150	Spring , 8x20	1		
151	Seal-oil , 20x35x10L	1		
152	Hub	1		
153	Handle	1	1120207204	1120207204
154	Pin , 5x50	1	92030550	92030550
155	Snap ring , S18	2		

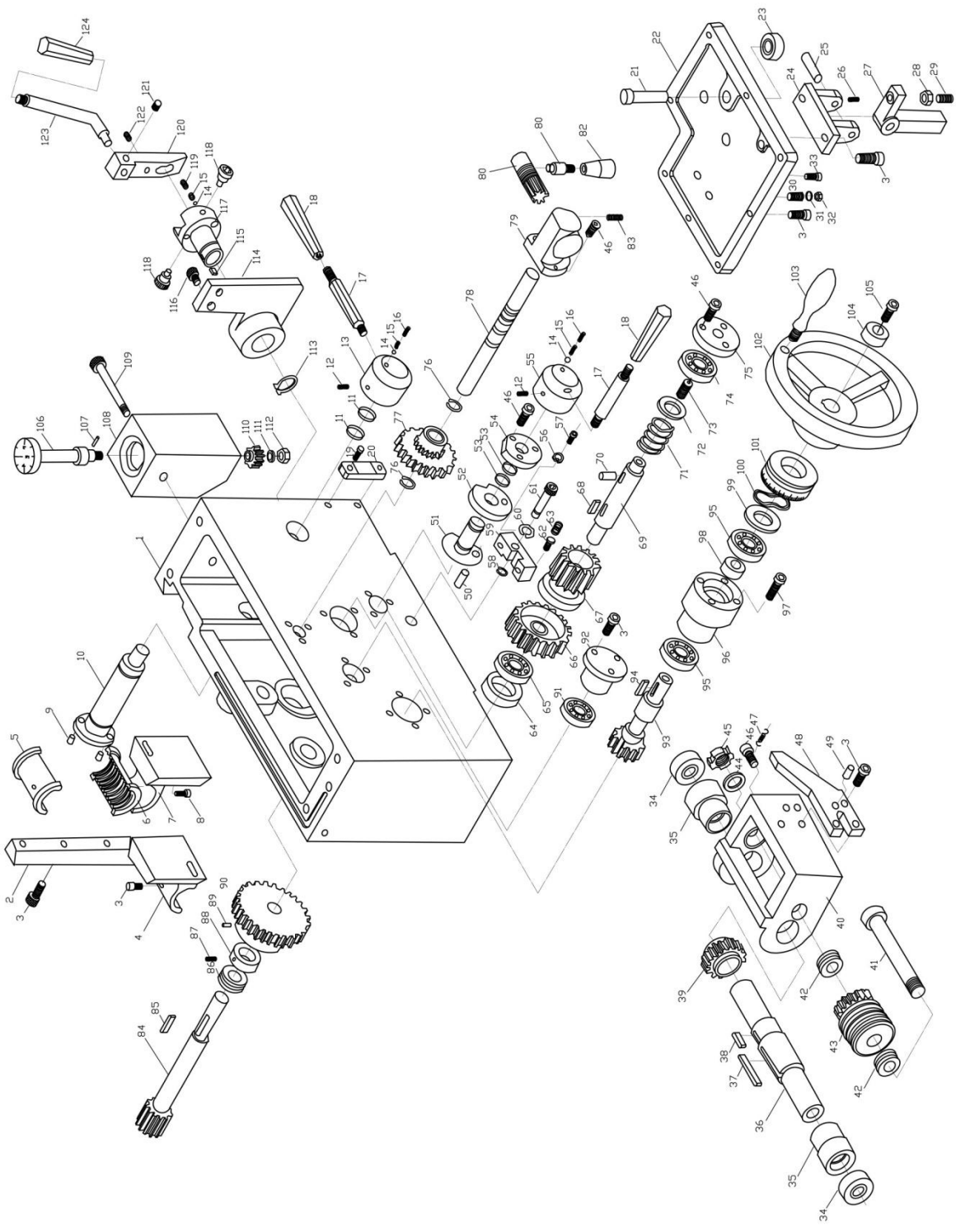

APRON ASSEMBLY

Item No.	Part Name	Amt. Used	Type: 16 Part No.	Type: 18 Part No.
1	Body-Apron (right)	1	1210900209	1210900209
	(left)	1	1210900101	1210900101
2	Gib	1	1210901706	1210901706
3	Screw-hexa. socket head cap, M6xP1.0x16L	17	91110616	91110616
4	Holder-half nut (right)	1	1210900405	1210900405
	(left)	1	1210900307	1210900307
5	Nut-half (in)	1	121090051	121090051
	(mm)	1	121090061	121090061
6	Nut-half (in)	1	121090051	121090051
	(mm)	1	121090061	121090061
7	Holder-half nut	1		
8	Screw-hexa. socket head cap, M6xP1.0x16L	1	91110616	91110616
9	Pin-sliding	2	1210902507	1210902507
10	Shaft-haft nut (right)	1	1210900807	1210900807
	(left)	1	1210900709	1210900709
11	Ring-O , P26	2	9151P026	9151P026
12	Screw-hexa. socket head cap, M8xP1.25x20L	2	1210902605	1210902605
13	Hub	1		
14	Ball-steel , 1/4"	3		
15	Spring , Ø 1x6x30L	3	91901060102902	91901060102902
16	Screw-hexa. socket headless set, M8xP1.25x10L	2	91120810	91120810
17	Lever	2	1210902703	1210902703
18	Knob	2		
19	Screw-hexa. socket head cap, M10xP1.5x25L	2	91111025	91111025
20	Lenx-oil	1	1210902801	1210902801
21	Shaft-auto stop	1	1210902909	1210902909
22	Cover-bottom apron	1	1210903004	1210903004
23	Seal-oil , 15x25x7	1	91521501	91521501
24	Seat-tappet	1	1121601804	1121601804
25	Shaft-tappet	1	1121601902	1121601902
26	Screw-hexa. socket headless set, M6xP1.0x16L	2		
27	Tappet	1	1121602007	1121602007
28	Nut , M8xP1.25	1		
29	Screw-hexa. socket headless set, M8xP1.25x30L	1	91102080300005	91102080300005
30	Screw-hexa. socket headless set, M6xP1.0x40L	1	91120640	91120640
31	Set screw , M6x40	1		
32	Nut , M6xP1.0	2		
33	Screw-oil leakage , PT1/4	1	92590601	92590601
34	Seal-oil , 32x42x10	2	91523210	91523210
35	Bushing	2	1210901804	1210901804
36	Sleeve-feed rod	1	1210901902	1210901902
37	Key-square , 6x6x42L	1	91610611	91610611

APRON ASSEMBLY

Item No.	Part Name	Amt. Used	Type: 16 Part No.	Type: 18 Part No.
38	Key-square , 6x6x12L	1	91610601	91610601
39	Gear	1	1210903200	1210903200
40	Seat-worm	1	1210903308	1210903308
41	Shaft-worm	1	1210903406	1210903406
42	Bearing-thrust , 2904	2		
43	Worm gear	1	1210902007	1210902007
44	Washer-lock , 20	1		
45	Nut	1		
46	Screw-hexa. socket head cap, M6xP1.0x12L	8	91110612	91110612
47	Spring, Ø 1x10x60L (right)	1	1210905400	1210905400
	(left)	1	1210905508	1210905508
48	Block-safe device (right)	1	1210901000	1210901000
	(left)	1	1210900905	1210900905
49	Pin, 5x18L	2	92030525	92030525
50	Pin (right)	1	1210901206	1210901206
	(left)	1	1210901108	1210901108
51	Shaft-auto feed (right)	1	1210901206	1210901206
52	Collar (left)	1	210901206	210901206
53	Ring-O , P16	2	9151P016	9151P016
54	Cover	1	1210903602	1210903602
55	Hub (right)	1	1210901402	1210901402
	(left)	1	1210901304	1210901304
56	Spring washer , M8	1		
57	Screw-hexa. socket head cap, M8xP1.25x12L	1		
58	Snap ring, S10	1		
59	Lever	1	1210903700	1210903700
60	Spring washer, M12	1	91420012	91420012
61	Screw	1	1210903808	1210903808
62	Screw-hexa. socket head cap, M5xP0.8x20L	1		
63	Spring	1	1210905606	1210905606
64	Spacer	1	1210903906	1210903906
65	Bearing ball, 6005V	1	91301012	91301012
66	Worm-wheel	1	1210902105	1210902105
67	Wheel-friction	1	1210902203	1210902203
68	Key-square, 7x7x12L	1		
69	Shaft-worm wheel	1	1210904001	1210904001
70	Pin	1	1210904109	1210904109
71	Spring, compressing	1	1210905302	1210905302
72	Washer	1	1210904207	1210904207
73	Screw-hexa. socket headless set	1		
74	Bearing-ball , 6204	1	91301018	91301018
75	Cover	1	1210904305	1210904305
76	Snap ring , S20	2	9171S020	9171S020
77	Gear	1	1210902301	1210902301
78	Shaft-cross feed	1	1210904403	1210904403

APRON ASSEMBLY

Item No.	Part Name	Amt. Used	Type: 16 Part No.	Type: 18 Part No.
79	Set (right)	1	1210901608	1210901608
	(left)	1	1210901500	1210901500
80	Shaft-lever	1	1210904501	1210904501
81	Lever	1		
82	Sleeve-lever	1		
83	Screw-hexa. socket headless set, M4xP0.7x10L	1		
84	Pinion-rack	1	1210904707	1210904707
85	Key-square , 6x6x20L	1	91610605	91610605
86	Bearing-niddle , NK20/22	1	91311001	91311001
87	Screw-hexa. socket headless set, M6xP1.0x10L	1	91120610	91120610
88	Collar	1	1210904805	1210904805
89	Pin-spring , 6x36L	1	92030636	92030636
90	Gear	1	1210904903	1210904903
91	Bearing-ball , 6003	1	91301005	91301005
92	Cover	1	1210905008	1210905008
93	Pinion-handwheel		1210905106	1210905106
94	Key-square , 6x6x25L	1	91610605	91610605
95	Bearing-ball , 6004V	1	91301008	91301008
95-1	Bearing-ball , 6004Z	1	91301007	91301007
96	Seat		1210905204	1210905204
97	Screw-hexa. socket head cap, M6xP1.0x30L	4	91110630	91110630
99	Washer	1	1210701608	1210701608
100	Washer-wave type	1		
101	Dial-rack (in)	1	1220900202	1220900202
102	Handwheel	1	1122101705	1122101705
103	Handle	1	1121102002	1121102002
104	Washer-lock	1	1122101901	1122101901
105	Screw-hexa. socket head cap, M8xP1.25x20L	1	91110820	91110820
106	Dial-thread chasing (in, 4 parts)		1003514708	1003514708
	(mm, 5 parts)	1	1003502404	1003502404
	(mm, 7 parts)	1	1003514904	1003514904
107	Pin	1		
108	Seat-dial shaft	1	1003514502	1003514502
109	Screw-hexa. socket head cap, M10xP1.5x65L	1	91111065	91111065
110	Gear (in 16T)	1	1003514600	1003514600
	(mm 11T)	1	1003502502	1003502502
	(mm 13T)	1	1003502600	1003502600
	(mm 14T)	1	1003514806	1003514806
	(mm 15T)	1	1003502708	1003502708
	(mm 18T)	1	1003502806	1003502806
111	Washer-spring , 10	1		
112	Nut , M10xP1.5	1	91210010	91210010
113	Snap ring , S30	1	9171S030	9171S030

APRON ASSEMBLY

Item No.	Part Name	Amt. Used	Type: 16 Part No.	Type: 18 Part No.
114	Seat-switch	1	1210701706	1210701706
115	Key-square , 6x8x25L	1	91610610	91610610
116	Screw-hexa. socket head cap, M8xP1.25x16L	2	91110816	91110816
117	Bracket	1	1210701804	1210701804
118	Screw-lock	2	1210701902	1210701902
119	Screw-hexa. socket headless cap, M8xP1.25x8L	1	1210702007	1210702007
120	Seat-lever	1	1210702105	1210702105
121	Screw-hexa. socket headless set, M8xP1.25x8L	2	91120808	91120808
122	Spring	1		
123	Lever	1	1210702203	1210702203
124	Knob	1	1122103601	1122103601

9-4 BED AND BASE

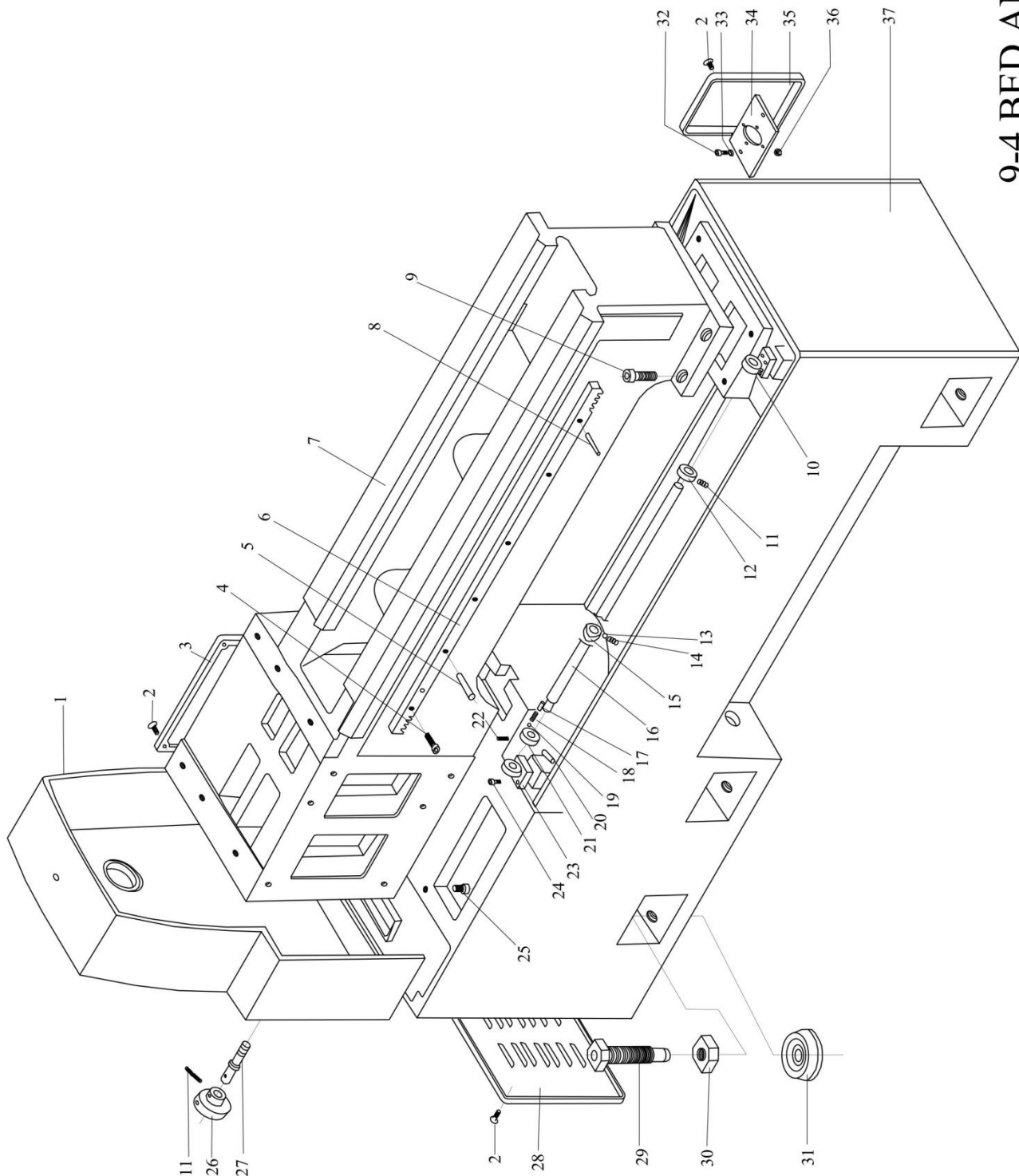

BED AND BASE ASSEMBLY

Item No.	Part Name	Amt. Used	Type: 16 Part No.	Type: 18 Part No.
1	Cover-end	1	1221600201	1221600201
2	Screw-cross-recessed head, M6xP1.0x20L	12		
3	Cover-electric box	1	1122102006	1122102006
4	Screw-hexa. socket head cap, M6xP1.0x25L	10	91110625	91110625
5	Pin-taper, 6x36	2		
6	Rack (5 feet)	1	1210701000	1210701000
	(6 feet , right)	1	1220700604	1220700604
	(6 feet , left)	1	1220700506	1220700506
	(8 feet)	1	1230700509	1230700509
	(10 feet)	1	1240700502	1240700502
7	Bed (5 feet)	1	1210100101	1210100101
	(6 feet)	1	1220100104	1220100104
	(8 feet)	1	1230100107	1230100107
	(10 feet)	1	1240100100	1240100100
8	Pin-taper , 6x36	2	92030636	92030636
9	Screw-hexa. socket head cap, M16xP2.0x45L	4	91111645	91111645
10	Supporter-shaft	1	1122102104	1122102104
11	Screw-hexa. socket headless set, M6xP1.0x10L	2	91120610	91120610
12	Collar	1	1122102202	1122102202
13	Shoe-brass	4	1122102300	1122102300
14	Screw-hexa. socket headless set, M6xP1.0x6L	1		
15	Cam-auto feed stopping	4	1122102408	1122102408
16	Shaft-auto stopping (5 feet)	1	1212100109	1212100109
	(6 feet)	1	1222100308	1222100308
	(8 feet)	1	1232100105	1232100105
	(10 feet)	1	1242100108	1242100108
17	Screw-hexa. socket headless set, M8xP1.25x8L	1	91120808	91120808
18	Spring , 1x6x8L	1	91910610	91910610
19	Ball-steel , 1/4"	1	91820104	91820104
20	Lever-turning shaft	4	1122103807	1122103807
21	Collar	1	1122103905	1122103905
22	Screw-hexa. socket headless set, M8xP1.25x10L	1	91120810	91120810
23	Supporter-shaft	1	1122102604	1122102604
24	Screw-hexa. socket head cap, M8xP1.25x16L	4	91110816	91110816
25	Screw-hexa. socket head cap, M16xP2.0x55L	8	91111655	91111655
26	Plug	1	1122102702	1122102702
27	Bolt-lock	1		
28	Cover-motor seat	2	1122100806	1122100806
29	Bolt-set machine	6	1122102800	1122102800
30	Nut-lock	6	1122102800	1122102800

BED AND BASE ASSEMBLY

Item No.	Part Name	Amt. Used	Type: 16 Part No.	Type: 18 Part No.
31	Block-leveling	6	1003501809	1003501809
32	Bolt-hexa. head , W1/4"x25	2		
33	Washer, W5/8"	2	91401051600003	91401051600003
34	Seat-coolant pump (5, 6feet)	1	1210100503	1210100503
	(8 feet)	1	1230100509	1230100509
	(10 feet)	1	1240100502	1240100502
35	Cover-coolant motor seat	1	1005000403	1005000403
36	Nut-lock , W1/4"	2		
37	Base (5 feet)	1	1210100209	1210100209
	(6 feet)	1	1220100202	1220100202
	(8 feet)	1	1230100205	1230100205
	(10 feet)	1	1246100208	1246100208

9-5 BRAKE SYSTEM

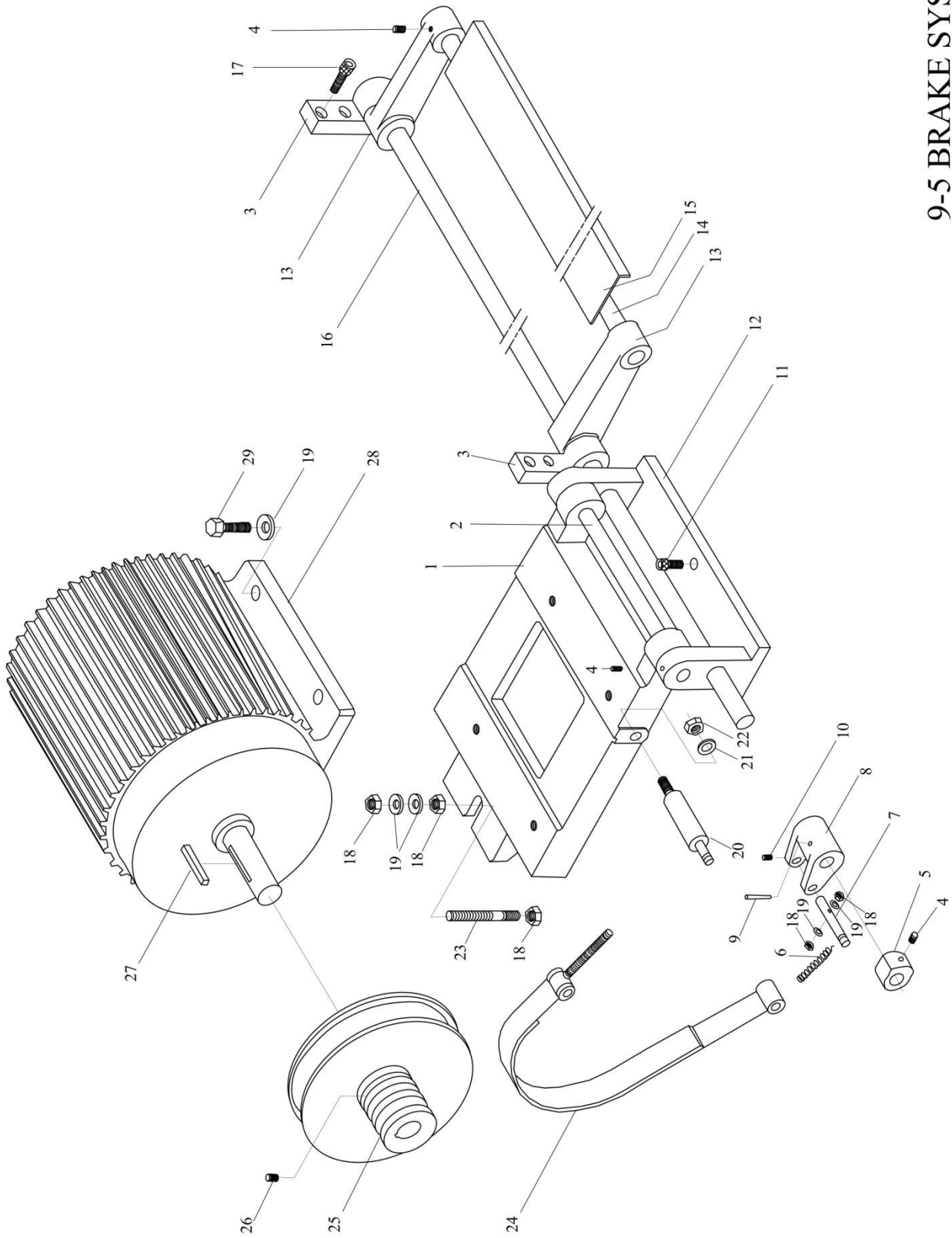

BRAKE SYSTEM ASSEMBLY

Item No.	Part Name	Amt. Used	Type: 16 Part No.	Type: 18 Part No.
1	Seat-motor	1	1210400606	1210400606
2	Shaft-motor seat	1	1210400204	1210400204
3	Block	2	1210100601	1210100601
4	Screw-hexa. socket headless set, M6xP1.0x15L	4	91102060160003	91102060160003
5	Cam	1	1210400606	1210400606
6	Spring	1	1210400302	1210400302
7	Shaft-brake	1	1210400704	1210400704
8	Arm-brake	1	1210400802	1210400802
9	Pin-taper , 4"x38L	1		
10	Screw-hexa. socket, M6xP1.0x10L	1		
11	Screw-hexa. socket head cap, M10xP1.5x20L	3	91111020	91111020
12	Bracket-motor seat	1	1210100709	1210100709
13	Bracket-pedal	2	1210400900	1210400900
15	Pedal-brake (5 feet)	1	1210400508	1210400508
	(6 feet)	1	1220400109	1220400109
	(8 feet)	1	1230400102	1230400102
	(10 feet)	1	1240400105	1240400105
16	Shaft-pedal bracket (5 feet)	1	1210100405	1210100405
	(6 feet)	1	1220100300	1220100300
	(8 feet)	1	1230100401	1230100401
	(10 feet)	1	1240100404	1240100404
17	Screw-hexa. socket head cap, M8xP1.25x25L	4	91110825	91110825
18	Nut , M16	5	91210016	91210016
19	Washer , M16	8	91410016	91410016
20	Bolt-adjusting	1	1210401005	1210401005
21	Washer , M12	1	91410012	91410012
22	Nut , M12	1	91210012	91210012
23	Bolt-adjusting	1	1210400400	1210400400
24	Belt-brake (5HP , 15HP)	1	1003519605	1003519605
	(7.5HP , 10HP)	1	1003519703	1003519703
25	Belt pulley (5HP/60HZ)	1	1000400805	1000400805
	(7.5HP/60HZ)	1	1000400501	1000400501
	(5HP/ 50HZ)	1	1000400609	1000400609
	(7.5HP /50HZ)	1	1000400707	1000400707
26	Screw-hexa. socket headless set, M8xP1.25x8L	1	91120608	91120608
27	Key, 8x7.5x40 (5HP)	1		
	10x8x65 (7.5HP)	1		
	(10HP)	1		
	12x8x80 (15HP)	1		
28	Motor	1		
29	Bolt-hexa. head , M10x30L	4		

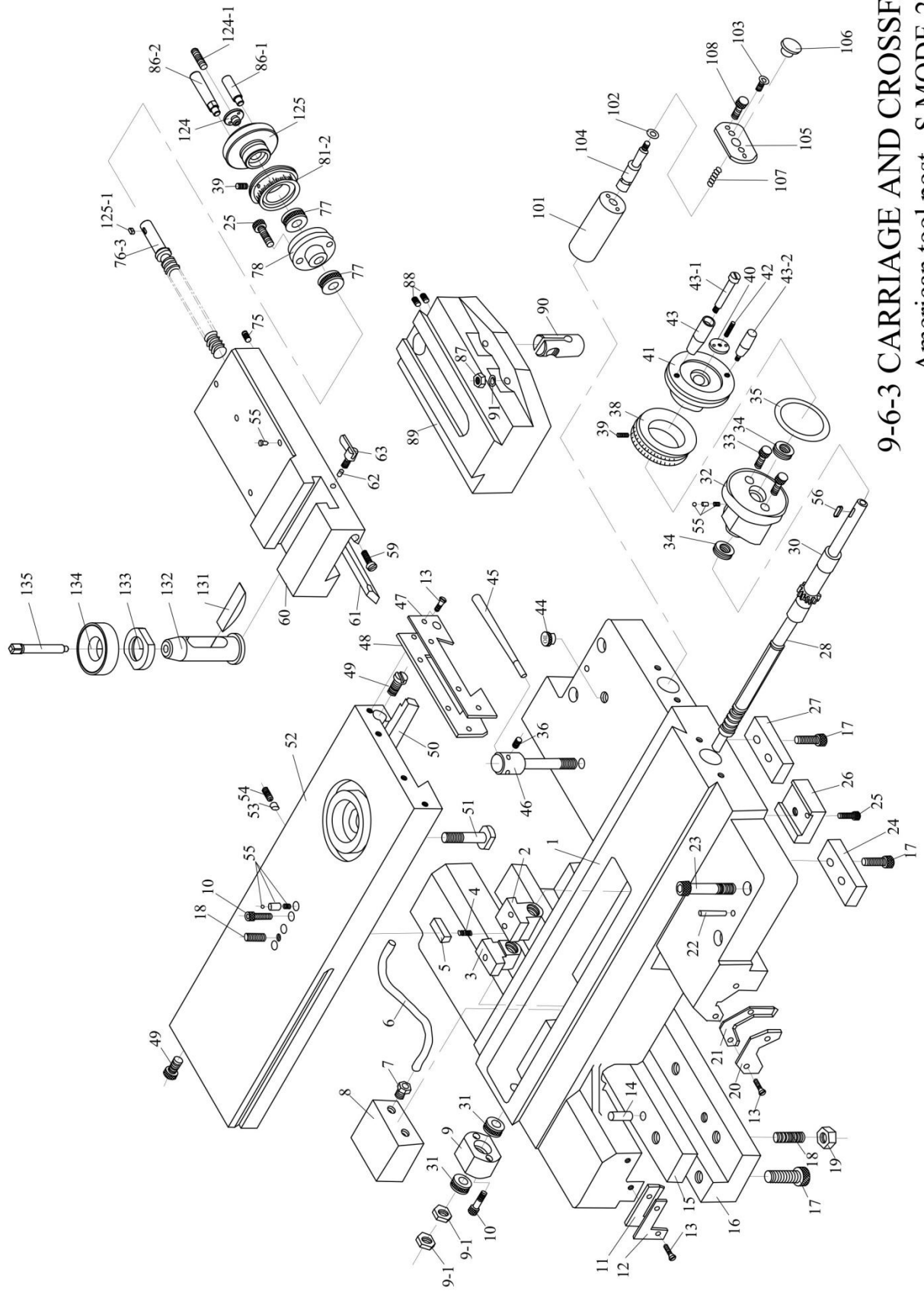

9-6-3 CARRIAGE AND CROSSFEED
 American tool post S MODE-202207

CARRIAGE AND CROSSFEED ASSEMBLY

Item No.	Part Name	Amt. Used	Type: 16 Part No.	Type: 18 Part No.
1	Carriage	1	122080109	122080109
2	Nut-crossfeed	1		
3	Nut-crossfeed	1		
4	Spring, 0.3x5x15L	1		
5	Shim-crossfeed nut	1	1120800901	1120800901
6	Pipe-lubrication oil	1		
7	Nut-copper	1		
8	Conveyor-oil	1	1120801006	1120801006
9	Cap-crossfeed screw	1	1120801104	1120801104
9-1	Nut-hexa. Head, M12xP1.25	2		
10	Hexagon socket screw, M6xP1.0x35L	5	91110635	91110635
11	Wiper-rear	1	1122100100	1122100100
12	Case-wiper , rear	1	1122100306	1122100306
13	Screw-cross-recessed, M4xP0.7x10L	8	91140410	91140410
14	Pin	2		
15	Gib	1	1220800207	1220800207
16	Holder-gib	1	1220800403	1220800403
17	Hexagon socket screw, M8xP1.25x20L	4	91110820	91110820
18	Set screw, M8xP1.25x20L	5	91120820	91120820
19	Nut, M8xP1.25	4		
20	Case-wiper, front	1	1122100404	1122100404
21	Wiper-front	1	1122100100	1122100100
22	Pin-taper, 6 # 75L	2	1210700503	1210700503
23	Hexagon socket screw, M10xP1.5x70L	4		
24	Gib-left-front	1	1120801202	1120801202
25	Hexagon socket screw, M6xP1.0x20L	3	91120620	91120620
26	Clamp-carriage	1	1120801300	1120801300
27	Gib-right-front	1	1120801408	1120801408
28	Screw-crossfeed (8TPI , in)	1	3006028-002A	3006028-002A
	(5MM , mm)	1	3006028-001A	3006028-001A
30	Pinion-crossfeed (local)	1	1220800501	1220800501
	(export)	1	1220800609	1220800609
31	Bearing thrust, 51101	1	91303001	91303001
32	Bracket	1	1120800107	1120800107
33	Bolt-hexa. Socket, M8xP1.25x40L	2	91110840	91110840
34	Bearing-thrust, 51103	2	91303002	91303002
35	Washer-wave type, 6210	2	91440001	91440001
36	Screw-hexa. Socket head cap headless set, M6xP1.0x10L	1	91120610	91120610
37	Clutch-dial	1	1120802807	1120802807

CARRIAGE AND CROSSFEED ASSEMBLY

Item No.	Part Name	Amt. Used	Type: 16 Part No.	Type: 18 Part No.
38	Dial-crossfeed (8TPI/left/export)	1	3006038-B01	3006038-B01
	(5MM/left/export)	1	1000802603	1000802603
39	Screw-hexa. Socket headless set, M6xP1.0x15L	1		
40	Nut (local)	1	1120803000	1120803000
	(export)	1	3004040-001	3004040-001
41	Handle-wheel (local)	1	1120802601	1120802601
	(export)	1	1120802709	1120802709
42	Screw-adjusting , M6xP1.0x30L	1		
43	Knob-handle (local)	1	1120803206	1120803206
	(export)	1	112083304	112083304
43-1	Screw-handle (export)	1	1120803500	1120803500
43-2	Knob-handle	1	1120803402	1120803402
44	Plug-oil inlet	1	1122103405	1122103405
45	Lever	1	1120801506	1120801506
46	Screw-carriage clamp	1	1120800607	1120800607
47	Case-wiper	1		
48	Wiper	1	1222100102	1222100102
49	Screw-adjusting	1	1120801604	1120801604
50	Gib	1	1220800305	1220800305
51	Bolt	4	1120800509	1120800509
52	Cover-cross sliding	1	1430800802	1430800802
53	Shoe-clamp	1	1220800707	1220800707
54	Set screw, M8xP1.25x20L	1	91120820	91120820
55	Ball-steel , 1/4"	4		
56	Square key, 5x5x15L	1	91610501	91610501
59	Screw-gib	2	112081702	112081702
60	Compound rest	1	3006060-317	3006060-319
61	Gib-compound rest	1		
62	Shoe-clamp	1	1220800707	1220800707
63	Screw-clamp	1		
75	Screw-gib, M8xP1.25x30L	1		
76-3	Screw-compound rest	1	3006076-003	3006076-003
77	Bearing-thrust, 51102	2		
78	Seat-compound rest screw	1		
81-2	Dial-compound rest	1	3006081-002	3006081-002
82	Washer-wave type	1		
86-2	Long-Knob-handle	1		
87	Nut, M10xP1.5	4		
88	Screw-hexa. socket headless cap, M8xP1.25x8L	2		
89	Swivel	1		
90	Nut-compound rest screw	1		
91	Spring washer , M10	4		
101	Body-pump	1	1120801800	1120801800
102	Ring-O , P10	1		

CARRIAGE AND CROSSFEED ASSEMBLY

Item No.	Part Name	Amt. Used	Type: 16 Part No.	Type: 18 Part No.
103	Screw-cross-recessed, M5xP0.8x12L	2		
104	Rod-pump	1	1120801908	1120801908
105	Stopper	1	1120802003	1120802003
106	Plug	1		1120802101
107	Spring-compressing, Ø 1.2x10x63L	1		
108	Screw-hexa. Socket head cap, M6xP1.0x16L	2	1120802209	1120802209
124	Nut	1	3006124	3006124
124-1	Set screw, M6xP1.0x25L	1		
125	Handle-wheel	1	3006125	3006125
125-1	Square key, 5x5x10L	1		
131	Tool block	1	3006131	3006131
132	Tool post	1	3006132	3006132
133	Tool buckle	1	3006133	3006133
134	Tool block seat	1	3006134	3006134
135	Locking bolt	1	3006135	3006135

9-7 TAIL STOCK

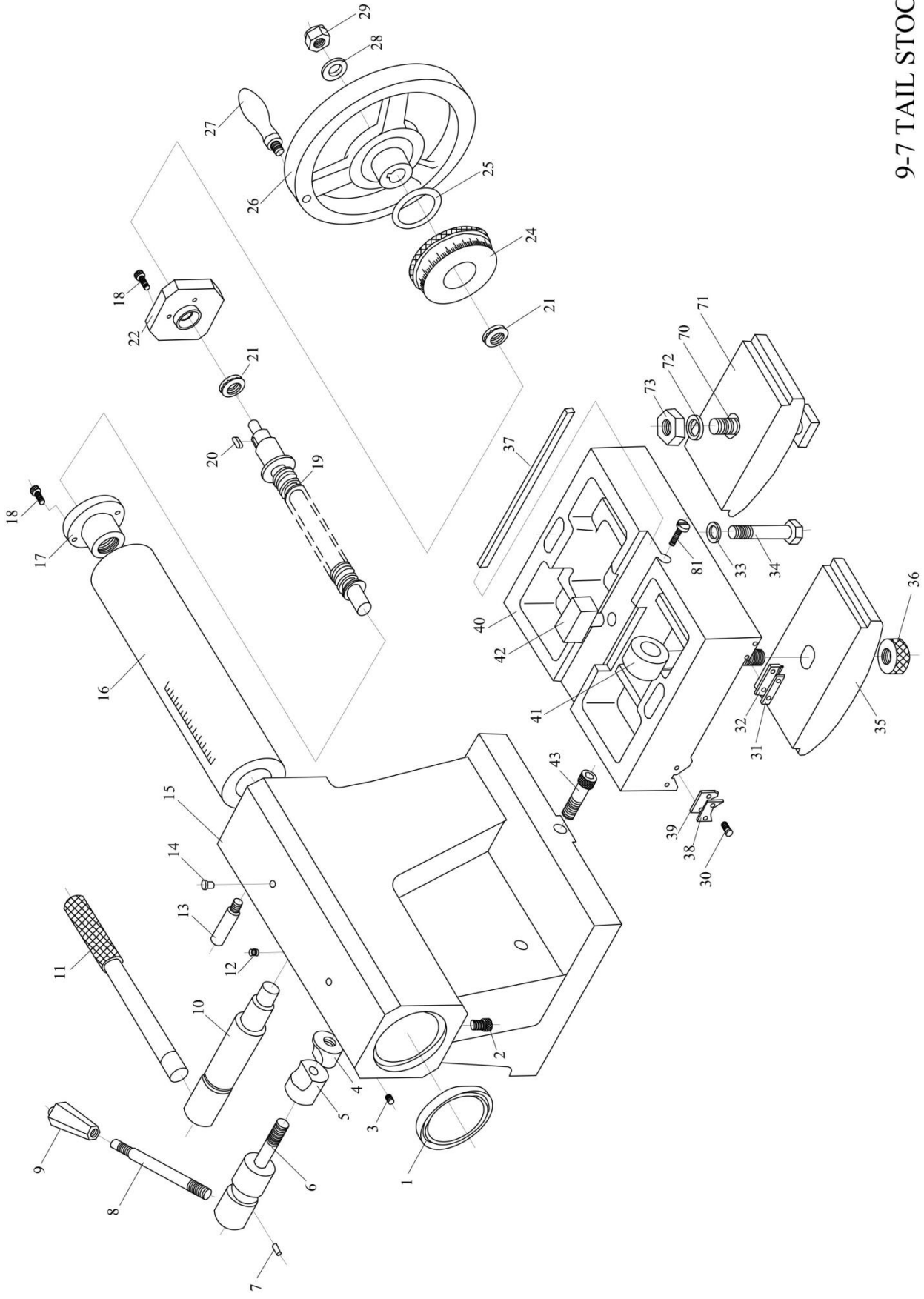

TAILSTOCK ASSEMBLY

Item No.	Part Name	Amt. Used	Type: 16 Part No.	Type: 18 Part No.
1	Seal-oil , TC68x90x12	1	91526801	91526801
2	Screw-hexa. socket head cap, M8xP1.25x10L	1	1121100802	1121100802
3	Screw-hexa. socket headless set, M6xP1.0x10L	1	91120610	91120610
4	Block-clamp	1	1121101005	1121101706
5	Block-clamp	1	1121101005	1121101706
6	Shaft-clamp spindle	1	1121101103	1121101804
7	Pin, 5x12	1		
8	Lever	1	1121102100	1121102100
9	Sleeve-lever	1	1120207400	1120207400
10	Shaft-clamp bottom	1	1121101201	1221100902
11	Lever	1	1121101201	1221100902
12	Screw-hexa. socket, M6xP1.0x20L	1	91120620	91120620
13	Screw-brake	1	1121102306	1121102306
14	Plug-oil	3		
15	Body-tailstock	1	1121100106	1121100106
16	Spindle-tang slot	1	1121101309	1121101309
17	Cap-spindle	1		
18	Screw-hexa. socket head cap, M6xP1.0x12L	3	91110612	91110612
19	Screw-spindle feed (in)	1		1221100304
	(mm)	1		1221100402
20	Key-square , 6x6x25	1	91610606	91610606
21	Bearing-thrust , 51204	2		
22	Cap-body end	1	1121101407	1221101105
23	Screw-hexa. socket head cap, 96xP1.0x25L	4		
24	Dial-feed (in)	1	1121100508	1221100500
	(mm)	1	1121100606	1221100608
25	Washer-wave type, 6205	1	91440002	91440002
26	Handwheel	1	1121100900	1121100900
27	Knob	1	1121102002	1121102002
28	Washer , 1/2"	1	9141S001	9141S001
29	Nut , 1/2-20UNF	1	9125S001	9125S001
30	Screw-cross-recessed, M4xP0.7x12L	4		
31	Case-wiper	2		
32	Wiper	2		
33	Washer-flat, M10	2	91410010	91410010
34	Bolt-clamp, M10xP1.5x75L	2		
35	Clamp	1		
36	Washer	1		
38	Case	1		
39	Wiper	1		
40	Bottom-tailstock	1		
41	Bolt-clamp	1		
42	Block-adjusting	1		
43	Screw-hexa. socket, M10xP1.5x80L	2	91111080	91111080

9-8 STEADY REST

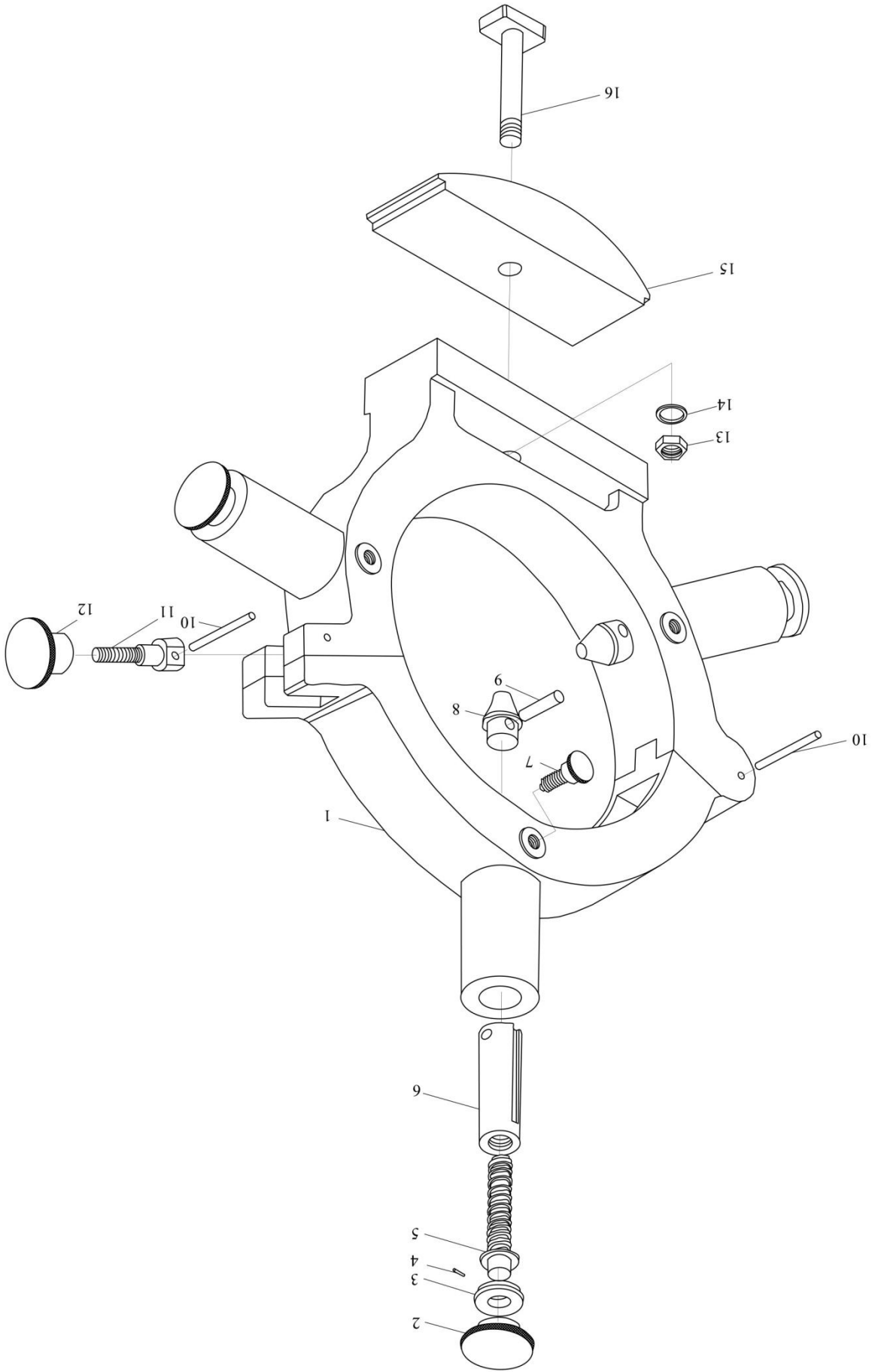

STEADY REST

Item No.	Part Name	Amt. Used	Type: 16 Part No.	Type: 18 Part No.
1	Steady-rest	3		
2	Plug-lead screw	3		
3	Cap, 6x52L	12		
4	Pin	3		
5	Lead-screw	3		
6	Nut-lead screw	1		
7	Screw-fixed	3		
8	Jaw	3		
9	Pin-fixed	3		
10	Pin , 9x25L	2		
11	Screw	1		
12	Plug	1		
13	Nut , W5/8"	1		
14	Washer	1		
15	Block-clamp	1	1003500204	1003500204
16	Bolt	1	1003500400	1003500400
	(6" Sleeve)		1003519203	1003501103
	(6" Bearing)		1003519301	1003501201
	(9" Sleeve)			1003501309
	(9" Bearing)			1003501407

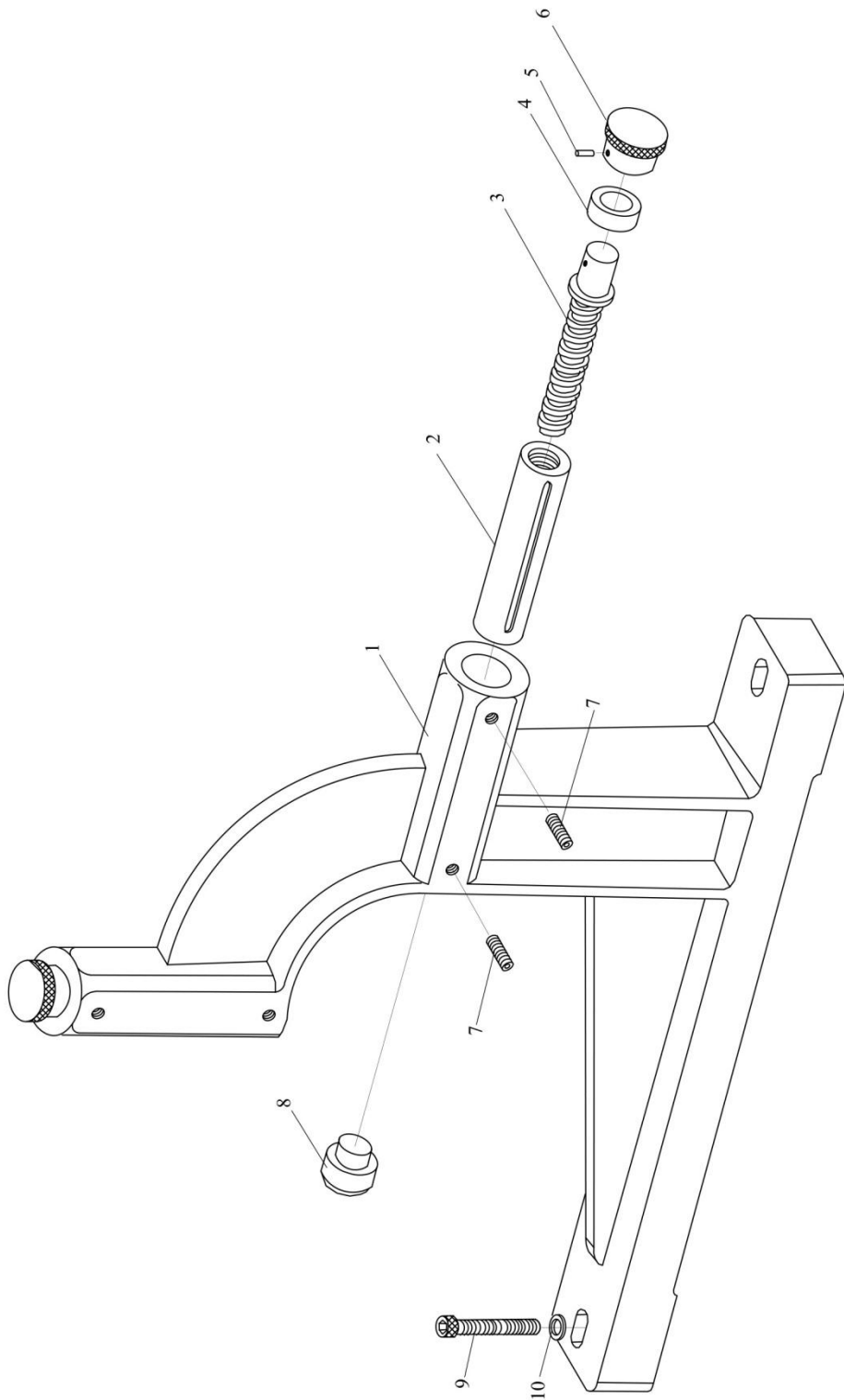

9-9 FOLLOW REST

FOLLOW REST ASSEMBLY

Item No.	Part Name	Amt. Used	Type: 16 Part No.	Type: 18 Part No.
1	Body-follow rest	1		
2	Nut-lead screw	2		
3	Lead-screw	2		
4	Collar	2		
5	Pin , 4x25L	2		
6	Plug-lead screw	2		
7	Screw-hexa. socket headless cap, M8xP1.25x10L	4		
8	Shoe	2		
9	Screw-hexa. socket head cap, M10xP1.5x30L	2	91111030	91111030
10	Washer			
	(6" Sleeve)			
	(6" Bearing)		10035019409	1003503107
	(9" Sleeve)		100352700	100352710
	(9" Bearing)			1003503107
				100352710

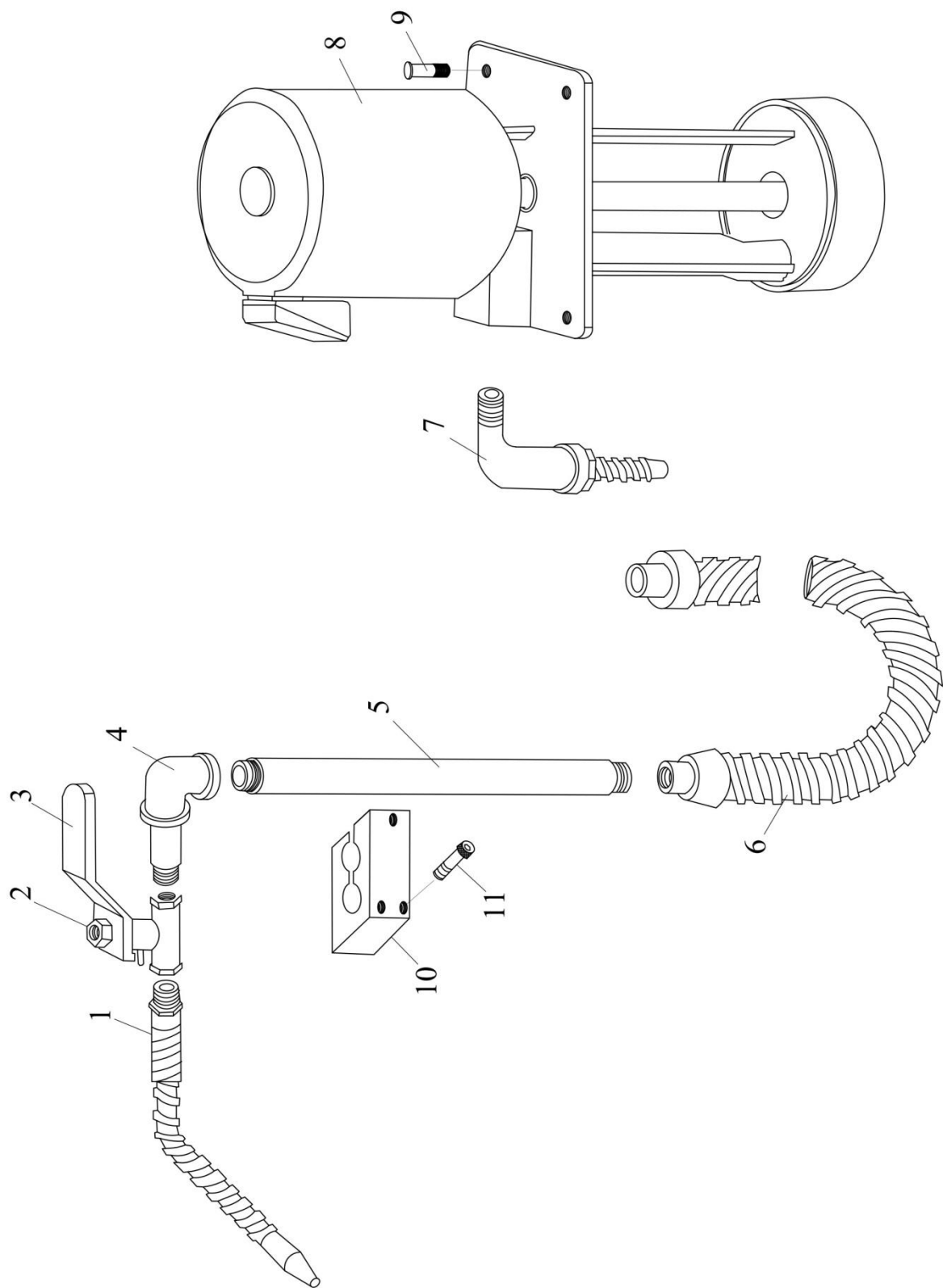

COOLANT SYSTEM ASSEMBLY

Item No.	Part Name	Amt. Used	Type: 16 Part No.	Type: 18 Part No.
1	Nozzle	1		
2	Nut-lock	1		
3	Cock-lever	1		
4	Elbow	1		
5	Rod-support	1		
6	Pipe (5, 6 feet)	1	92605002	92605002
	(8 feet)	1	92605003	92605003
	(10 feet)	1	92605001	92605001
7	Elbow	1		
8	Pump body	1		
9	Bolt-hex. head, M6xP1.0x12L	2		
10	Supporter-lock pipe	1		
11	Screw-hexa. socket head cap, M6xP1.10x20L	3	91110620	91110620