



PRECISION MACHINE TOOLS

SURFACE GRINDERS

- SH 1224 -

SHARP INDUSTRIES INC.

3501 Challenger Street Torrance, CA 90503

TEL: 310-370-5990

FAX: 310-542-6162

E-MAIL: info@sharp-industries.com

www.sharp-industries.com

--TABLE OF CONTENTS--

MACHINE ASSEMBLY P.3

LONGITUDINAL STRUCTURE P.6

CROSS STRUCTURE P.10

VERTICAL STRUCTURE P.14

SPINDLE ASSEMBLY P.18

HYDRAULIC SYSTEM P.22

PARALLEL DRESSING ATTACHMENT P.25

MACHINE ASSEMBLY

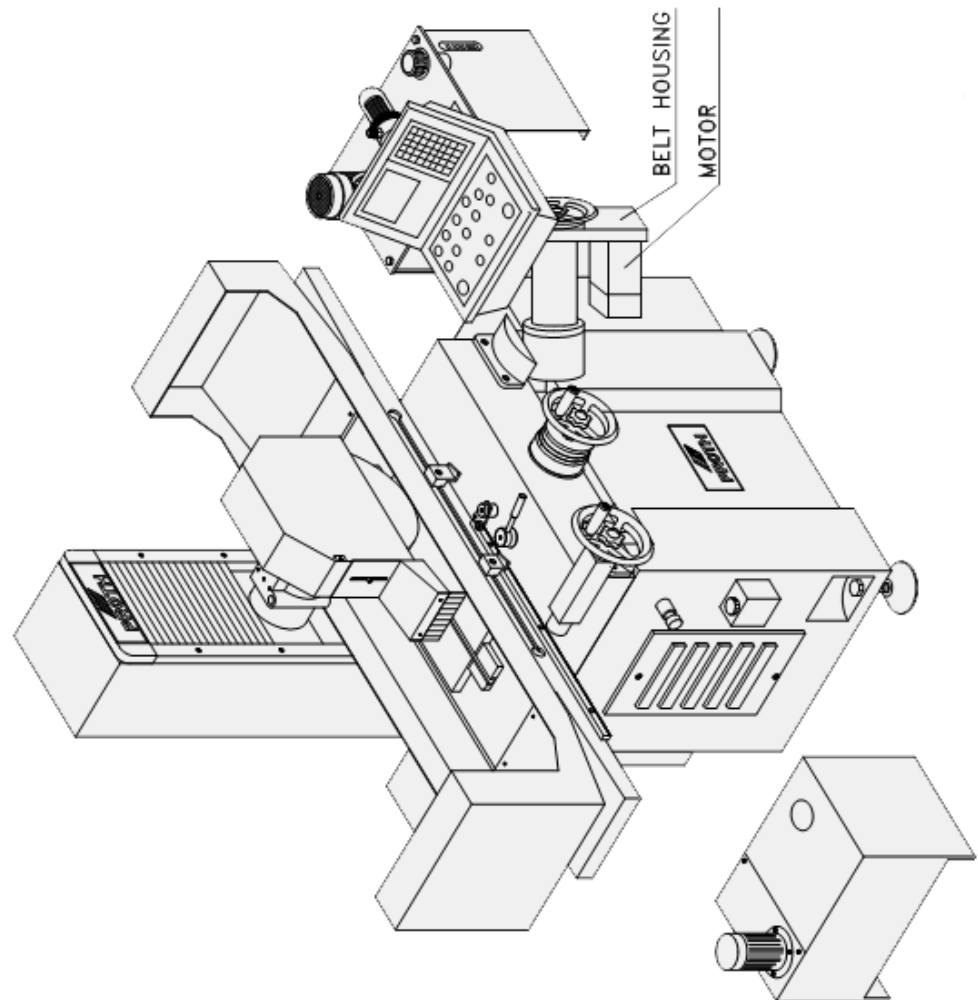

MACHINE BASE STRUCTURE

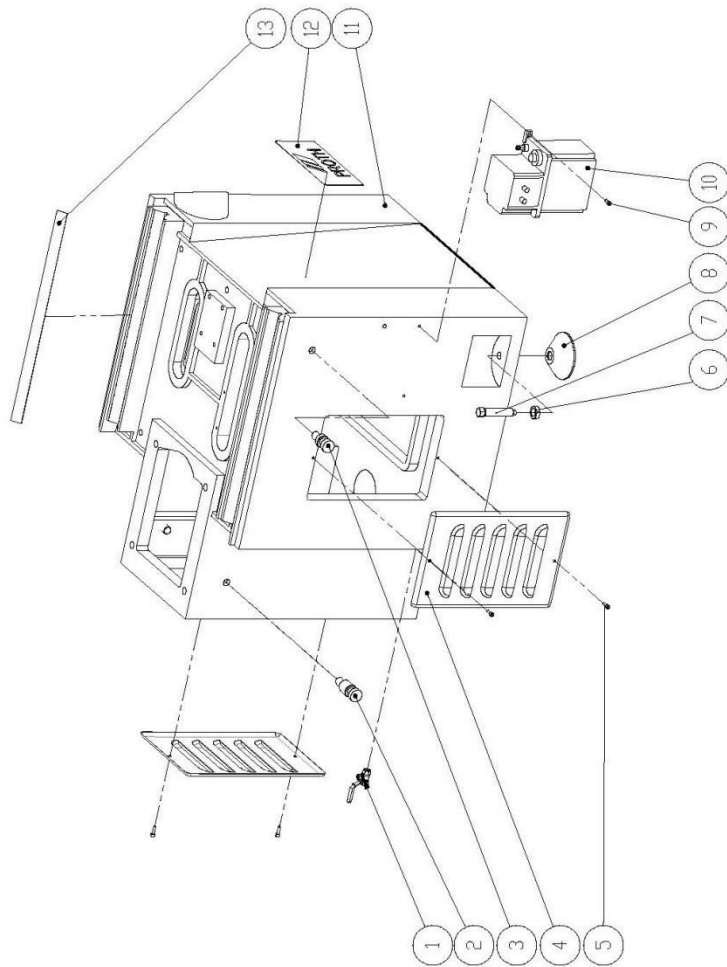

SERVICE GRINDER

序號 INDEX NO	件號 PART NO	品名 PART NAME		數量 QUANTITY
1	L7-1/2B	球閥	VALVE	1
2	SD9114A*	大吊栓	FLYING RING M20X2.5P	2
3	SD9115A*	小吊栓	FLYING RING M20X2.5P	2
4	SD9113A*	通風蓋板	VENTILATION COVER	2
5		圓頭十字螺絲	SCREW	4
6		外六角螺帽	NUT	3
7	SD9111A*	腳座螺絲	JACK BOLTS	3
8	SD9112A*	腳墊盤	MOUNTING BASE	3
9		內六角螺絲	SCREW	2
10	CESW(1)	電動注油機	ADJUSTABLE AUTO LUBE PUMP	1
11	SF1111A*	主機座	MACHINE BASE	1
12	SD9116A*	公司銘板	NAME PLATE PROTH	1
13	I3-630-1	特氟龍	TURCITE	4

LONGITUDINAL STRUCTURE

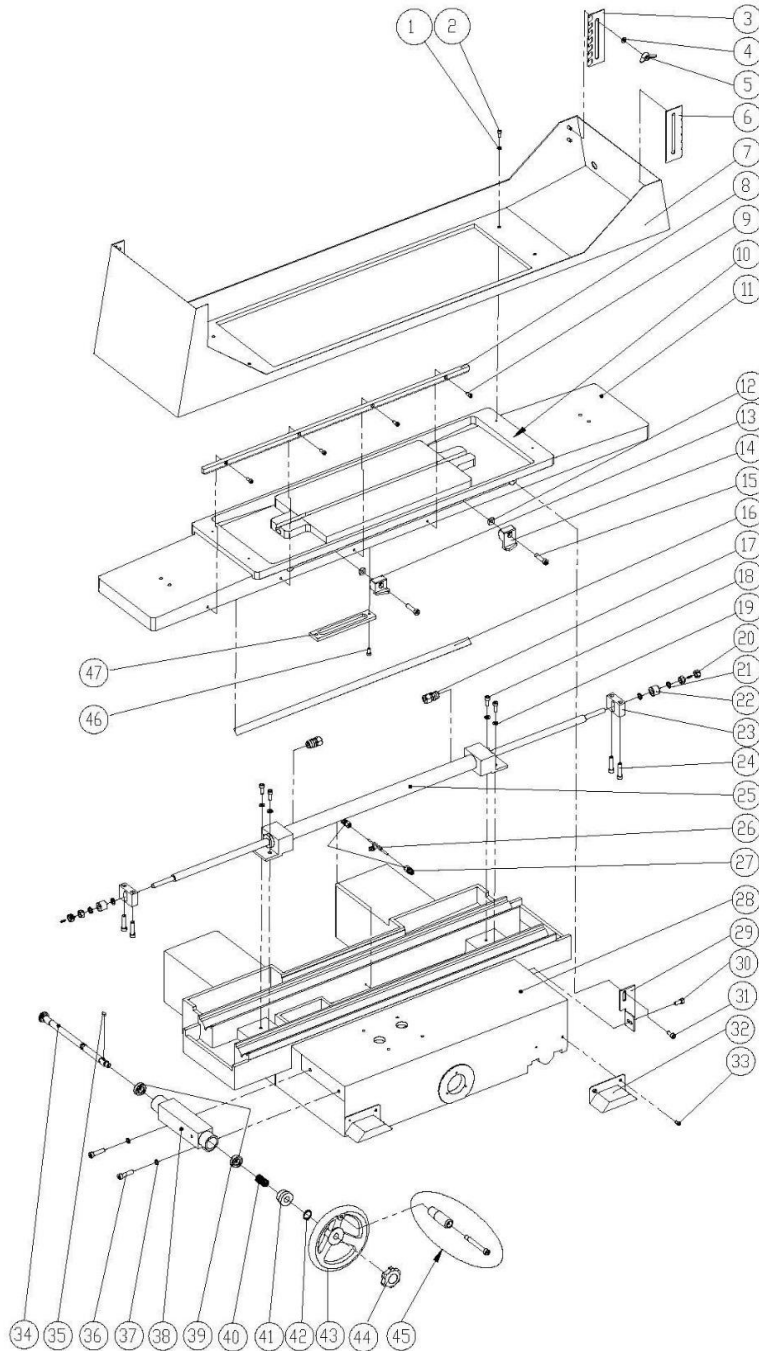

SERVICE GRINDER

序號 INDEX NO	件號 PART NO	品名 PART NAME		數量 QUANTITY
1		墊圈	WASHER	4
2		內六角螺絲	SCREW	4
3	SD2315A*	掛勾(右後)	HOOK	1
4		墊圈	WASHER	4
5		蝶型螺母	NUT	4
6	SD2314A*	掛勾(右前)	HOOK	1
7	SF2311A*	防濺槽	TABLE SPLASH GUARD	1
8	SF2111A*	齒排	RACK	1
9		內六角螺絲	SCREW	4
10	G-E20	保溫帶	TAPE	1
11	SF1113A*	工作台	TABLE	1
12	SD2112A*	調距螺母	NUT M8*1.25P	4
13	SD2114A*	左調距滑塊	TRIP DOG (LEFT)	1
14	SD2113A*	右調距滑塊	TRIP DOG (RIGHT)	1
15		內六角螺絲	SCREW	2
16	I3-800	特氟龍	TURCITE	4
17	I-C1/2	銅接頭	JOINT	2
18	M8×1.25*2	耐落螺絲	SCREW	4
19		墊圈	WASHER	4
20		螺母	NUT	4
21		墊圈	WASHER	4

序號 INDEX NO	件號 PART NO	品名 PART NAME		數量 QUANTITY
22	SD2116A*	墊套	WASHER	2
23	SD2115A*	驅動座	ROD DRIVER	2
24		內六角螺絲	SCREW	4
25	SF2210A*	油壓缸	CYLINDER	1
26	油壓附件	三通	JOINT	1
27	油壓附件	直接頭	JOINT	2
28	SF1112A*	滑動座	SADDLE	1
29	SD2564A*	工作台固定片	FIXED PLATE	1
30		內六角螺絲	SCREW	1
31		內六角螺絲	SCREW	1
32	SF3145A*	滑座護蓋	SADDLE COVER	2
33		內六角螺絲	SCREW	4
34	SD2412A*	齒桿	PINION	1
35		平行鍵	KEY	1
36		內六角螺絲	SCREW	2
37		墊圈	WASHER	2
38	SF2411A*	手動傳動軸座	BEARING HOLDER	1
39	6003ZZ	軸承	BEARING	2
40	SD2413A*	彈簧	SPRING	1
41	SD2414A*	銅套	HOSE	1
42		R 型扣環	R-RING	1
43	SD2555A*	把手輪	HANDWHEEL	1

序號 INDEX NO	件號 PART NO	品名 PART NAME		數量 QUANTITY
44	SD2556A*	梅花螺帽	NUT	1
45	SD2550A*	把手桿總成	HANDLE	1
46		內六角螺絲	SCREW	2
47	SF2127A*	漏水孔壓板	SPLASH GUARD ON COOLANT OPENING OF TABLE	1

CROSS STRUCTURE

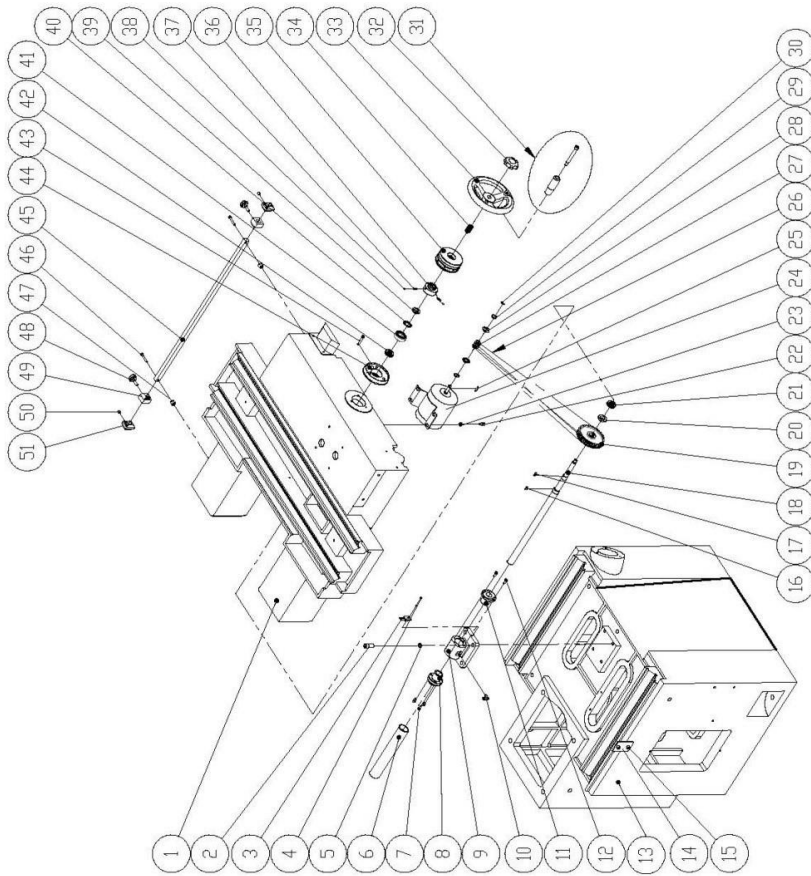

SERVICE GRINDER

序號 INDEX NO	件號 PART NO	品名 PART NAME		數量 QUANTITY
1	SF1112A*	滑動座	SADDLE	1
2		內六角螺絲	SCREW	4
3	SD3191A*	毛刷	BRUSH	1
4		十字型圓頭螺絲	SCREW	1
5		墊圈	WASHER	4
6	SD3122A*	保護管	PROTECTION TUBE	1
7		內六角螺絲	SCREW	3
8	SF3110A*	螺母	NUT	1
9	SD3119A*	前後螺桿座	NUT HOLDER	1
10	油壓附件	直角接頭	JOINT	1
11	SF3110A*	螺母	NUT	1
12		內六角螺絲	SCREW	2
13	SF1111A*	主機座	MACHINE BASE	1
14	SD3159A*	工作台固定片	FIXED PLATE	1
15		內六角螺絲 + 墊圈	SCREW+WASHER	2
16		平行鍵	KEY	1
17		平行鍵	KEY	1
18	SF3110A*	前後螺桿組	LEADSCREW ON CROSS IN METRIC	1
19	SD3113A*	時規皮帶輪	PULLEY	1
20	SD3114A*	間隔環	SPACER	1

序號 INDEX NO	件號 PART NO	品名 PART NAME		數量 QUANTITY
21	51104	軸承	BEARING	1
22		內六角螺絲	SCREW	4
23		墊圈	WASHER	4
24	SD3123A*	前後馬達	CROSS MOTOER	1
25		平行鍵	KEY	1
26		時規皮帶	TIMING BELT	1
27	SD3124A*	時規皮帶輪	PULLEY	1
28	SD3125A*	皮帶輪護片	PULLEY COVER	2
29		R 型扣環	R-RING	2
30		E 型扣環	E-RING	1
31	SD2550A*	把手桿總成	HANDLE	1
32	SD2556A*	梅花螺帽	NUT	1
33	SD3555A*	把手輪	HAND WHEEL	1
34	SD3126A*	彈簧	SPRING	1
35	SD3116A*	前後刻度盤	GRADUATED DIAL ON CROSS IN METRIC	1
36	SD3117A*	離合器聯軸座	CLUTCH HOLDER	1
37	SD3118A*	彈簧	SPRING	3
38		鋼珠	BALL	3
39	T7-AN04	止動螺母	NUT	1
40	T4-AW04	止動華司	WASHER	1
41	1204	軸承	BEARING	1
42	51104	軸承	BEARING	1

序號 INDEX NO	件號 PART NO	品名 PART NAME		數量 QUANTITY
43	SD3133A*	特殊螺絲	SCREW	3
44	SD3115A*	前後指示盤	INDICATOR	1
45	SD3128A*	調距導軌	SLIDEWAYS OF TRIP DOG	1
46		內六角螺絲	SCREW	2
47	SD3127A*	前後調距座	TRIP DOG HOLDER	2
48		T 字型螺絲	T SCREW	2
49	SD3129A*	極限滑塊	TRIP BLOCK	2
50		止付螺絲	SCREW	2
51	SD3131A*	調距滑塊	TRIP DOG	2

VERTICAL STRUCTURE

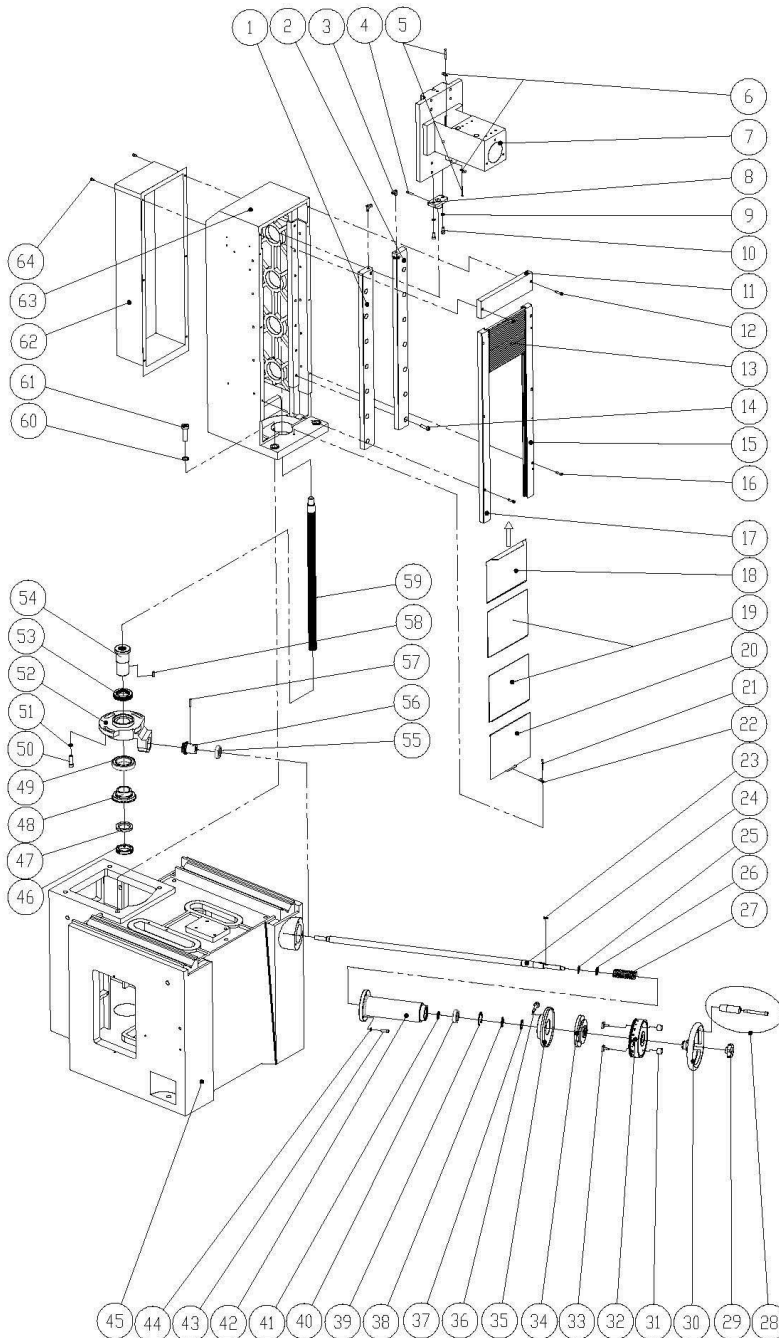

SERVICE GRINDER

序號 INDEX NO	件號 PART NO	品名 PART NAME		數量 QUANTITY
1	SD4121A*	上下滑板	VERTICAL SLIDEWAYS	1
2	SD4122A*	上下滑板	VERTICAL SLIDEWAYS	1
3	油壓附件	直角接頭	JOINT	2
4		彈簧銷	SPRING	1
5		十字型圓頭螺絲	SCREW	2
6	油壓附件	單面單管夾	CABLE CLAMPER 4mm	2
7	SG1115A*	主軸座	SPINDLE HOUSING	1
8	SD4413A*	上下頂座	VERTICAL HOLDER	1
9		彈簧華司	SPRING WASHER	2
10		內六角螺絲	SCREW	2
11				
12		內六角螺絲	SCREW	2
13	SD4115A*	防塵布	BELLOWS COVER	1
14	CA4123A*	滑板螺絲	SCREW	14
15	SD4114A*	上機架側蓋板	COLUMN COVER	1
16		內六角螺絲	SCREW	6
17	SD4113A*	上機架側蓋板	COLUMN COVER	1
18	SD4118A*	下 4 號防塵片	METAL COVER(4)	1
19	SD4117A*	下 2,3 號防塵片	METAL COVER(2,3)	2
20	SD4116A*	下 1 號防塵片	METAL COVER	1
21		十字型圓頭螺絲	SCREW	1

序號 INDEX NO	件號 PART NO	品名 PART NAME		數量 QUANTITY
22	油壓附件	單面單管夾	CABLE CLAMPER	1
23		平行鍵	KEY	1
24	SF4416A*	上下傳動軸	VERTICAL SHAFT	1
25		扣環	25C-RING	2
26	SD4315A*	彈簧墊圈	SPRING WASHER	1
27	SD4314A*	彈簧	SPRING	1
28	SD2550A*	把手桿總成	HANDLE	1
29	SD2556A*	梅花螺帽	NUT	1
30	SD3555A*	把手輪	HAND WHEEL	1
31	SD4324A*	螺母	NUT	2
32	SD4321A*	刻度盤	GRADUATED DIAL	1
33	SD4323A*	固鎖螺絲	LOCKING SCREW	2
34	SD4322A*	離合器	CLUTCH	1
35	SD4312A*	指示盤	INDICATOR	1
36	SD4313A*	指示盤螺絲	SCREW	1
37	T7-AN05	止動螺母	NUT	1
38	T4-AW05	止動華司	WASHER	1
39		C型扣環	C52-RING	1
40	1205	軸承	BEARING	1
41	SD4315A*	彈簧墊圈	SPRING WASHER	1
42	SD4311A*	上下軸座	VERTICAL SHAFT HOLDER	1
43		內六角螺絲	SCREW	3

序號 INDEX NO	件號 PART NO	品名 PART NAME		數量 QUANTITY
44		墊圈	WASHER	3
45	SF1111A*	主機座	MACHINE BASE	1
46	YSR50	軸承螺帽	NUT	1
47	SK4423A*	間隔環	SPACER	1
48	SD4421A*	大傘齒輪	BEVEL GEAR	1
49	6012ZZ	軸承	BEARING	1
50		內六角螺絲	SCREW	3
51		墊圈	WASHER	3
52	SD4414A*	傳動傘輪座	HOLDER OF BEVEL GEAR	1
53	51111	軸承	BEARING	1
54	SD4410A*	螺母	NUT	1
55	6304ZZ	軸承	BEARING	1
56	SD4422A*	左旋小傘齒輪	BEVEL GEAR	1
57		彈簧銷	SPRING	1
58		平行鍵	KEY	1
59	SD4410A*	上下螺桿	LEADSCREW ON VERTICAL	1
60		彈簧華司	SPRING WASHER	4
61		外六角螺絲	SCREW	4
62	SD4124A*	通風後蓋板	VENTILATION COVER	1
63	SD1114A*	上機架	COLUMN	1
64		十字型圓頭螺絲	SCREW	6

SPINDLE ASSEMBLY

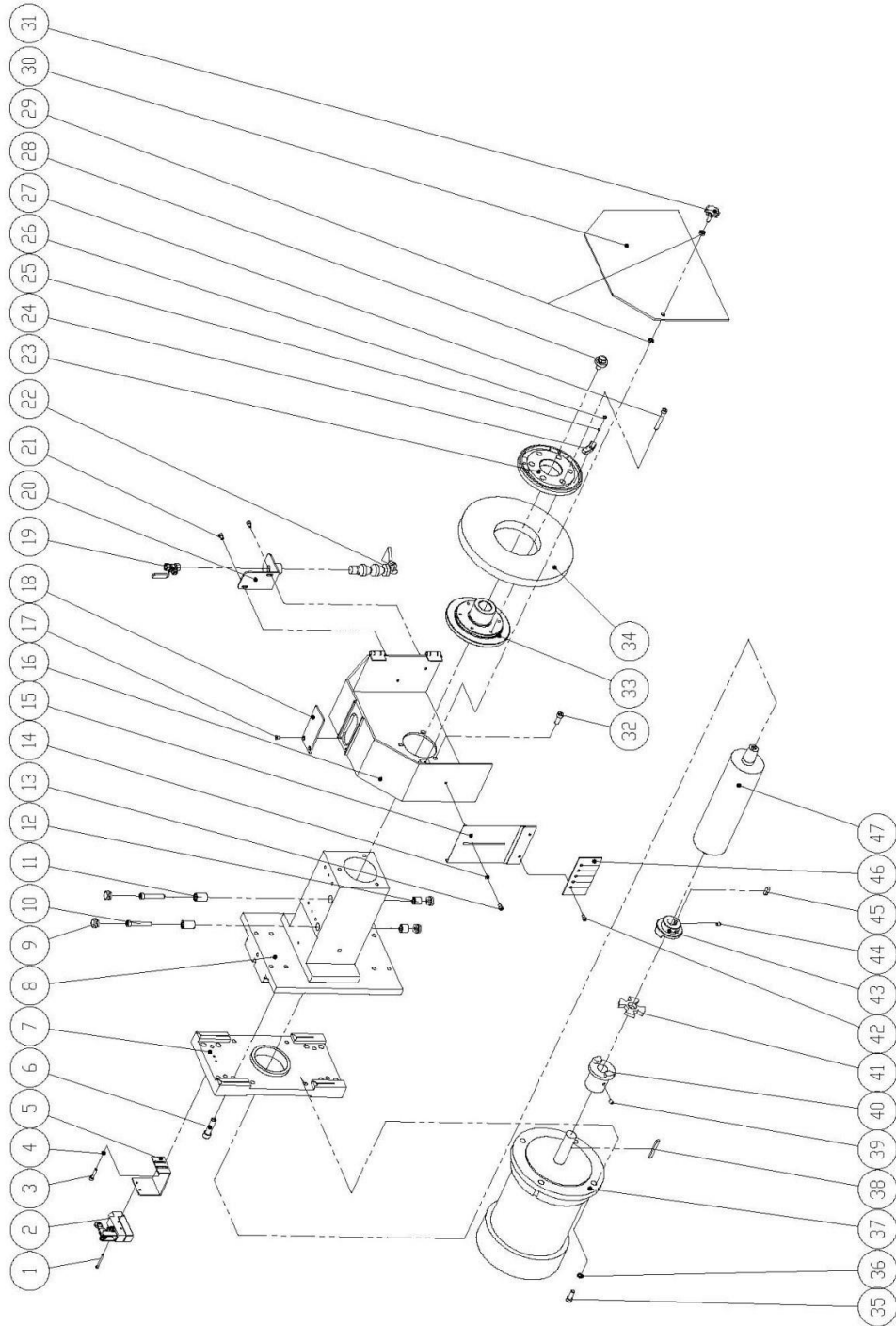

SERVICE GRINDER

序號 INDEX NO	件號 PART NO	品名 PART NAME		數量 QUANTITY
1		十字型圓頭螺絲	SCREW	2
2	MJ1-6104	極限開關	LIMIT SWITCH	1
3		內六角螺絲	SCREW	2
4		墊圈	WASHER	2
5	SD4126E*	極限擋塊	LINIT BLOCK	1
6		內六角螺絲	SCREW	12
7	SD1116A*	主軸座背鎖板	SPINDLE HOUSING HOLDER	1
8	SG1115A*	主軸座	SPINDLE HOUSING	1
9	SD5117A*	防塵塞	PLUG	4
10		內六角螺絲	SCREW	2
11	SD5113A*	主軸壓柱	FIXED ELEMENT	2
12	SD5114A*	主軸壓柱	FIXED ELEMENT	2
13		螺絲	SCREW	1
14		墊圈	WASHER	1
15	SK5314A*	防濺板	SPLASH GUARD OF WHEEL	1
16	SD5311A*	砂輪後蓋	REAR COVER OF WHEEL	1
17		平頭螺絲	SCREW	2
18	SK5313A*	砂輪蓋蓋板	COVER OF WHEEL	1
19	L7-1/2B	球閥	VALVE	1

序號 INDEX NO	件號 PART NO	品名 PART NAME		數量 QUANTITY
20	SK6318A*	水管固定座	HOLDER	1
21		內六角螺絲	SCREW	2
22	SD6312E*	組合式沖水管	COOLANT TUBE ASSEMBLY	1
23	SD5213A*	鎖緊面盤	LOCKING BOARD	1
24	SD5214A*	平衡塊	BALANCING WEIGHT	3
25		鋼珠	BALL	3
26		止付螺絲	SCREW	3
27		內六角螺絲	SCREW	6
28	SD5211A*	主軸螺絲	SPINDLE SCREW	1
29		螺帽	NUT	2
30	SD5312A*	砂輪前蓋	FRONT COVER OF WHEEL	1
31		薔薇型螺絲	SCREW	1
32		內六角螺絲	SCREW	3
33	SD5212A*	法蘭主體	WHEEL FLANGE	1
34	M6-14A	砂輪	WHEEL	1
35		內六角螺絲	SCREW	4
36		墊圈	WASHER	4
37	SD5111A*	主軸馬達	SPINDLE MOTOR	1
38		平行鍵	KEY	1
39		止付螺絲	SCREW	1
40	SD5112A*	聯軸器(馬達)	COUPLING(FOR MOTOR)	1

序號 INDEX NO	件號 PART NO	品名 PART NAME		數量 QUANTITY
41	SD5118A*	聯軸器墊	COUPLING	1
42		十字型圓頭螺絲	SCREW	2
43	SA5116A*	聯軸器(主軸)	COUPLING(FOR SPINDLE)	1
44		止付螺絲	SCREW	1
45		平行鍵	KEY	1
46	SK5315A*	防濺布	SPLASH GUARD	1
47	SG5211A*	主軸	SPINDLE	1

HYDRAULIC SYSTEM

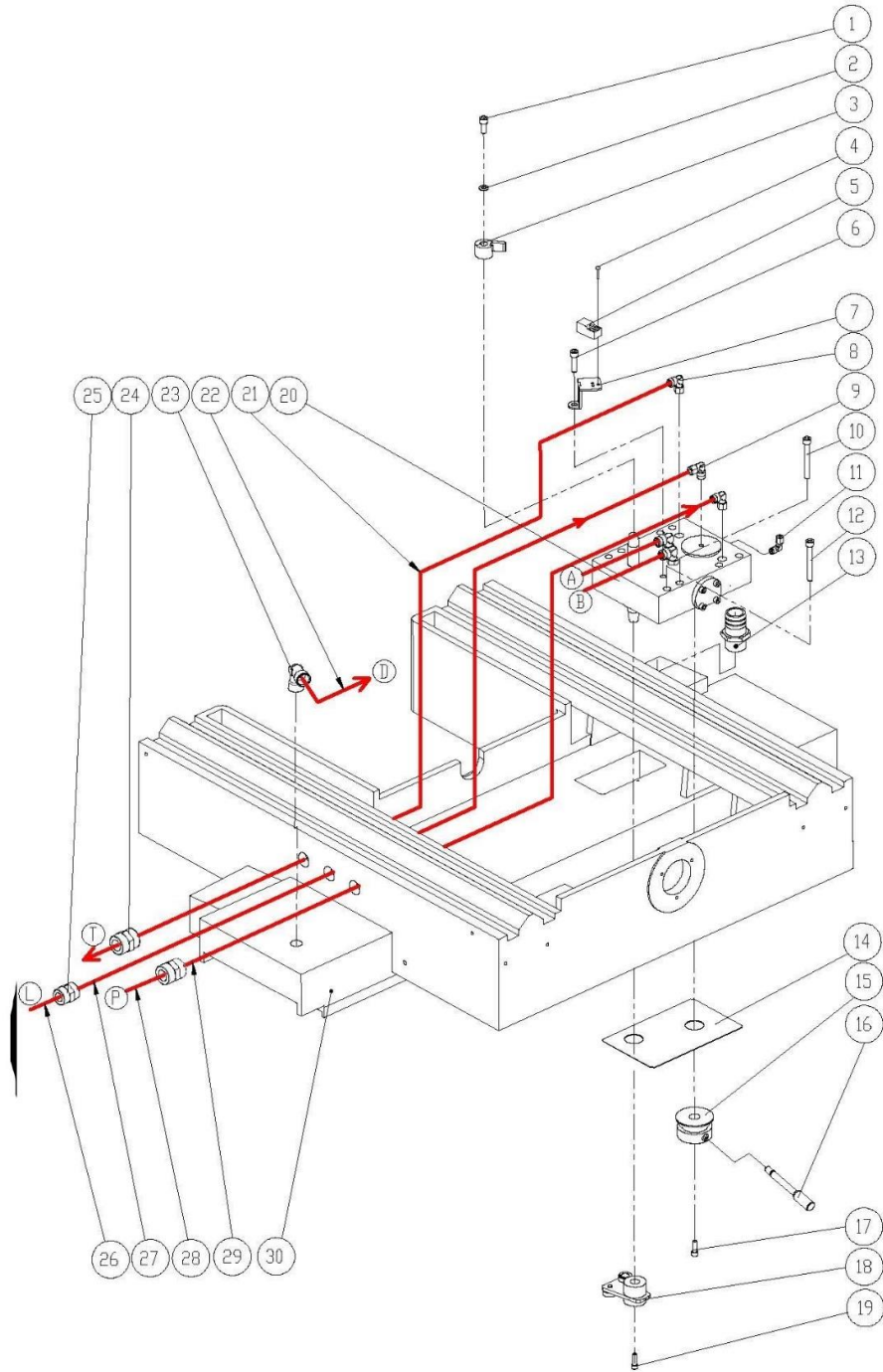

SERVICE GRINDER

序號 INDEX NO	件號 PART NO	品名 PART NAME		數量 QUANTITY
1		內六角螺絲	SCREW	1
2		墊圈	WASHER	1
3	SD6156AA	方向凸輪	DIRECTIONAL CAM	1
4		十字型圓頭螺絲	SCREW	2
5	PNP	近接開關	PROXIMITY SWITCH	1
6		內六角螺絲	SCREW	1
7	SD6155A*	微動開關座	SWITCH HOLDER	1
8	I-L1/2	銅接頭	JOINT	4
9	J-1/8×1/4	彎接頭 90	JOINT	1
10		內六角螺絲	SCREW	4
11	PH401	直角接頭	JOINT	1
12		內六角螺絲	SCREW	4
13	SK6311AB	漏水接頭	JOINT	1
14	SD6154A*	油壓銘板	OIL NAMEPLATE	1
15	SD6152A*	流量閥把手	FLOW CONTROL HANDLE	1
16	SD6153A*	流量閥把手桿	FLOW CONTROL HANDLE	1
17		內六角螺絲	SCREW	1
18	SD6140A*	方向搖臂	DIRECTIONAL CONTROL ARM	1
19		內六角螺絲	SCREW	1

序號 INDEX NO	件號 PART NO	品名 PART NAME		數量 QUANTITY
20	SD6110A*	油壓閥	SEALS OF HYDRAULIC CONTROL VALVE	1
21		高壓尼龍管	HIGH PRESSURE TUBE	1
22	N11/2×1.1A	鋼絲透明管	HOSE	1
23	J-1/2×1/2	彎接頭	JOINT	1
24	25643	油管接座	JOINT	2
25		油管接座	JOINT	1
26	N3-1/4×1.1	油壓管	HOSE	1
27	N3-1/4×800	油壓管	HOSE	1
28	N3-1/2×1.2A	油壓管	HOSE	2
29		高壓尼龍管	HIGH PRESSURE TUBE	1
30	SF1112A*	滑動座	SADDLE	1

PARALLEL DRESSING ATTACHMENT

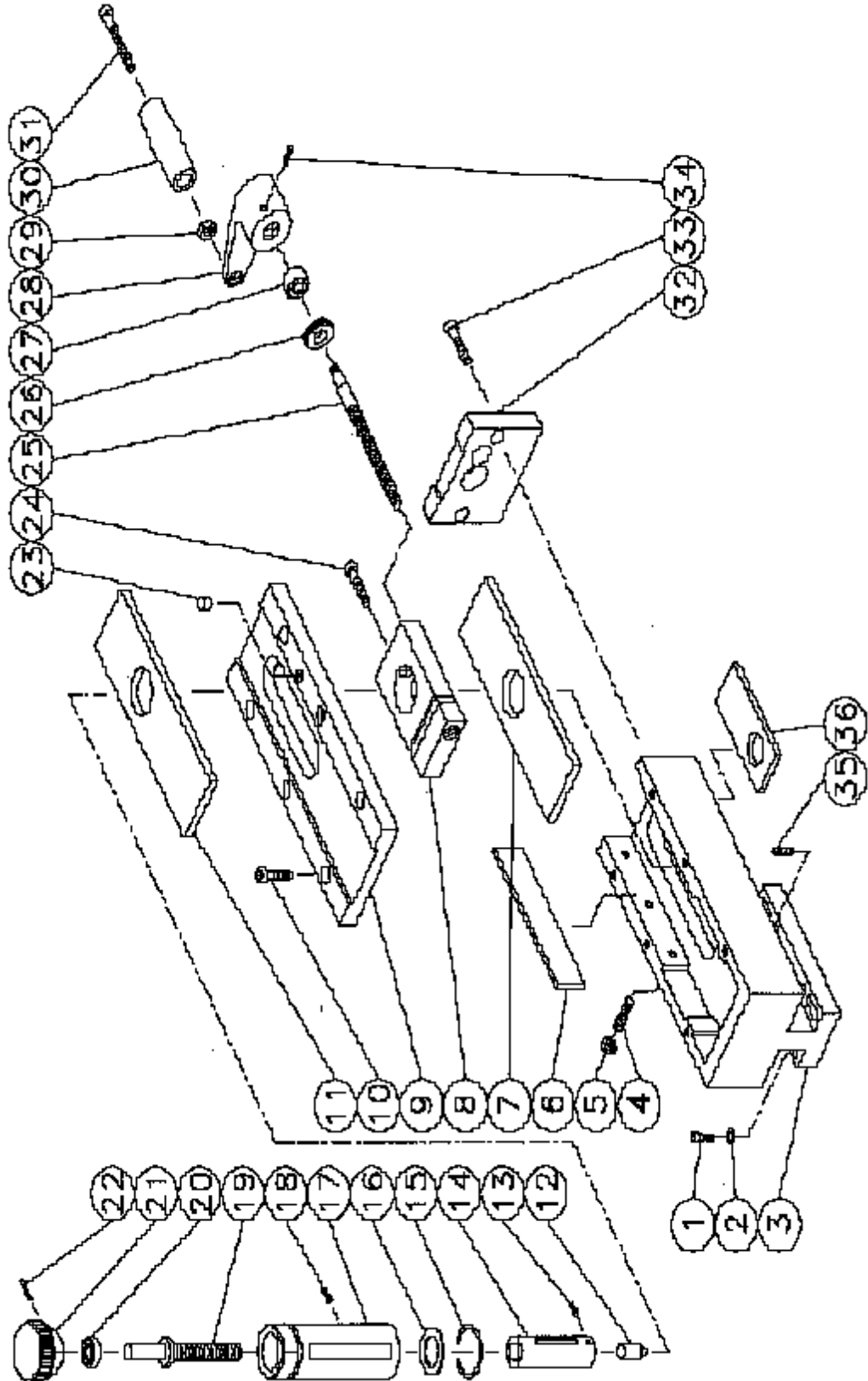

SERVICE GRINDER

序號 INDEX NO	件號 PART NO	品名 PART NAME		數量 QUANTITY
1		螺絲	SCREW	4
2		墊圈	WASHER	4
3		平行整輪座	MAIN BODY	1
4		螺絲	SCREW	3
5		螺母	NUT	3
6		固定片	WEDGE	1
7		下心軸固定片	LOWER COVER	1
8		調距滑塊	TRIP DOG	1
9		平行整輪護蓋	COVER	1
10		螺絲	SCREW	6
11		上心軸固定片	UPPER COVER	1
12		鑽石修刀	DIAMOND DRESSER	1
13		螺絲	SCREW	2
14		平行整輪心軸	SHAFT	1
15		扣環	LOCKING RING	1
16		油封	SEAL	1
17		心軸座	HOUSING	1
18		螺絲	SCREW	1
19		螺絲	SCREW	1
20		軸承	BEARING	1

序號 INDEX NO	件號 PART NO	品名 PART NAME		數量 QUANTITY
21		刻度盤	GRADUATED DIAL	1
22		斜梢	WEDGE	1
23		油栓	OIL INJECTOR	1
24		螺絲	SCREW	1
25		螺絲	SCREW	1
26		軸承	BEARING	1
27		軸承	BEARING	1
28		把手桿座	HANDLE CAM	1
29		螺母	NUT	1
30		把手桿	HANDLE	1
31		螺絲	SCREW	1
32		前護蓋	FRONT COVER	1
33		螺絲	SCREW	2
34		螺絲	SCREW	1
35		螺絲	SCREW	4
36		護蓋	COVER	1