

CHAPTR 9 Annex

9.1 Electrical circuit diagram (For TPR720A,TPR820A,TPR920A CE Standard)

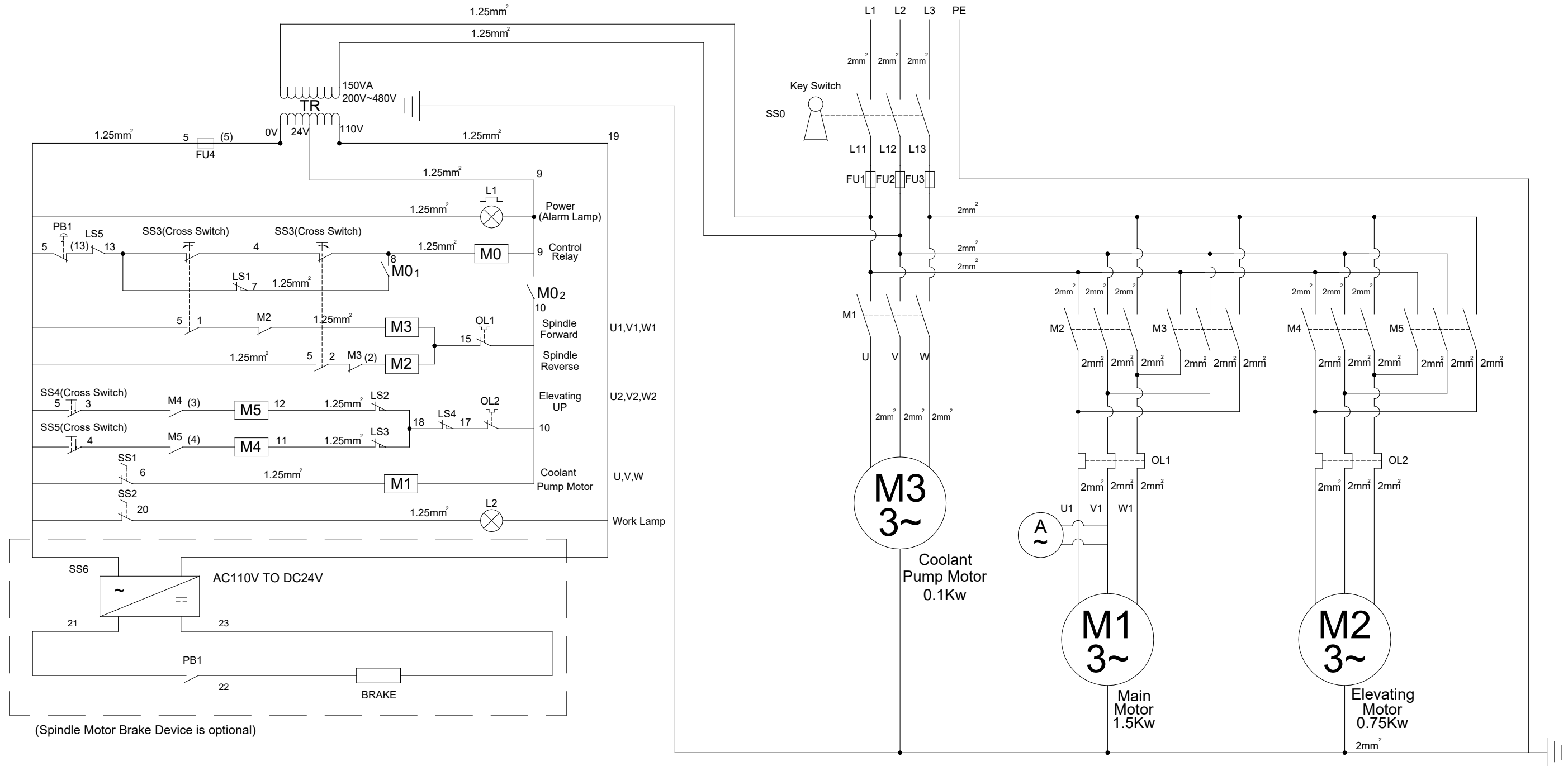

**9.2 Electrical circuit diagram
(For TPR-1100 CE Standard)**

