

Annex1 Electrical circuit diagram (TPR-C1250A,TPR-C1600 Standard) for 110V

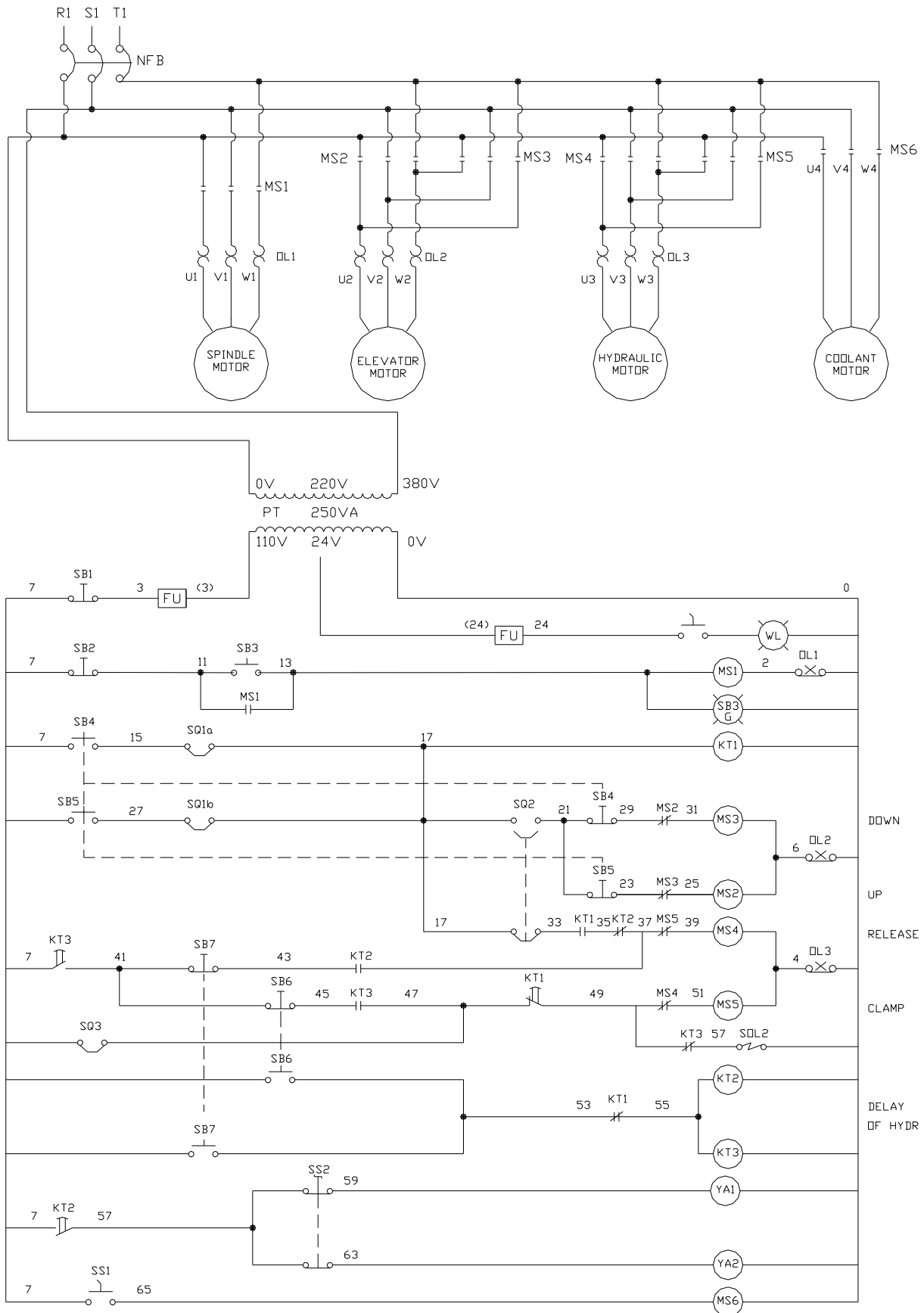

Annex2 Electrical Main Parts list (TPR-C1250A,TPR-C1600)

Part No.	Symbol	Name	Specification	Q'ty	Remark
E0403003	NFB	Circuit breaker	3P. 30A	1	For 200~240V
E0403004	NFB	Circuit breaker	3P. 20A	1	For 380~480V
E0701021	MS1	Magnetic Contact	CU18 3a1a1b AC110V	1	
E0701020	MS2	Magnetic Contact	CU11 3a1b 110V	1	
E0701020	MS3	Magnetic Contact	CU11 3a1b 110V	1	
E0701020	MS4	Magnetic Contact	CU11 3a1b 110V	1	
E0701020	MS5	Magnetic Contact	CU11 3a1b 110V	1	
E0701020	MS6	Magnetic Contact	CU11 3a1b 110V	1	
E0207057	OL1	Over load relay	RHU 10/11.3~16	1	For 200~240V
E0207055	OL2	Over load relay	RHU 10/15.5~7.5	1	For 200~240V
E0207054	OL3	Over load relay	RHU 10/3.5~4.8	1	For 200~240V
E0207056	OL1	Over load relay	RHU 10/9~12.5	1	For 380~480V
E0207054	OL2	Over load relay	RHU 10/3.5~4.8	1	For 380~480V
E0207053	OL3	Over load relay	RHU 10/1.8~2.5	1	For 380~480V
	PT	Transformer	250VA 1:0,220,380,415,440V 2:0,24,110V	1	Optional
E3101009	Fu	Fuse	E16	2	
E3101013	Fu	Fuse	E16 6A	2	
E0701016 E0209001	KT1	Timer Relay	LC1D09F7 110V+LA3DR0	1	0.1~3 sec
E0701016 E0209001	KT2	Timer Relay	LC1D09F7 110V+LA3DR0	1	0.1~3 sec
E0701016 E0210001	KT3	Timer Relay	LC1D09F7 110V+LA2DT2	1	0.1~3 sec
E1618002	SB1	Emg. Rush Button	XB4-BS542	1	
E1202019 E1202025	SB2	Push Button	ZB4-BA1+ZB4-BZ102	1	
E1202003	SB3	Push Button	YK22Φ 110V green	1	
E1202022 E1202020	SB4	Push Button	ZB4-BA2+ZB4-BZ105	1	
E1202022 E1202020	SB5	Push Button	ZB4-BA2+ZB4-BZ105	1	
E1202022 E1202020	SB6	Push Button	ZB4-BA2+ZB4-BZ105	1	
E1202022 E1202020	SB7	Push Button	ZB4-BA2+ZB4-BZ105	1	

Part No.	Symbol	Name	Specification	Q'ty	Remark
E1302004	SS1	Selector switch	YK22Φ 1A1B (B)	1	
E1302022 E1302023	SS2	Selector switch	ZB4-BD3+ZB4-BZ104	1	
		Spindle Motor	vertical 5HP 4P 3PH	1	
		Ascending/ Descending Motor	vertical 2HP 4P 3PH	1	
		Cooling Motor	1/4HP 2P	1	
E0303015		Terminal block	Ta020*45P	1	
M0302014	YA1	Solenoid	MFJ 1-3 110V	1	
M0302014	YA2	Solenoid	MFJ 1-3 110V	1	
E1617001	SQ1	Travel Switch	HZ4-22	1	
E0901007	SQ2	Limit Switch	1704	1	
E0901007	SQ3	Limit Switch	1704	1	
E1701001	WL	Work Lamp	A-L301C 24V/20W	1	

Annex3 Electrical Main Parts list (TPR-C2500)

Part No.	Symbol	Name	Specification	Q'ty	Remark
E1401020 E0403029	SS0	Key Switch	EZAROTE 3P30A100B	1	For 380~480V Optional CE
E1401020 E0403011	SS0	Key Switch	EZAROTE 3P50A100B	1	For 200~240V Optional CE
E0403003	NFB	Circuit breaker	3P. 30A	1	For 380~480V
E0403009	NFB	Circuit breaker	3P. 50A	1	For 200~240V
E0701022	MS1	Magnetic Contact	CU27 3a1a1b AC110V	1	
E0701021	MS2	Magnetic Contact	CU11 3a1a1b AC110V	1	
E0701021	MS3	Magnetic Contact	CU11 3a1a1b AC110V	1	
E0701020	MS4	Magnetic Contact	CU11 3a1b AC110V	1	
E0701020	MS5	Magnetic Contact	CU11 3a1b AC110V	1	
E0701020	MS6	Magnetic Contact	CU11 3a1b AC110V	1	
E0703006	MS1	Magnetic Contact	CU27 3a1a1b AC24V	1	Optional
E0703005	MS2	Magnetic Contact	CU18 3a1a1b AC24V	1	Optional
E0703005	MS3	Magnetic Contact	CU18 3a1a1b AC24V	1	Optional
E0703004	MS4	Magnetic Contact	CU11 3a1b AC24V	1	Optional
E0703004	MS5	Magnetic Contact	CU11 3a1b AC24V	1	Optional
E0703004	MS6	Magnetic Contact	CU11 3a1b AC24V	1	Optional
E0207061	OL1	Over load relay	RHU 80/24.5~36A4	1	For 200~240V
E0207057	OL2	Over load relay	RHU 10/11.36~16	1	For 200~240V
E0207054	OL3	Over load relay	RHU 10/3.5~4.8	1	For 200~240V
E0207059	OL1	Over load relay	RHU 80/17~25A4	1	For 380~480V
E0207056	OL2	Over load relay	RHU 10/9~12.5	1	For 380~480V
E0207053	OL3	Over load relay	RHU 10/1.8~2.5	1	For 380~480V
	PT	Transformer	500VA 1:0,200V~480V 2:0,24,110V	1	Optional
E3101009	Fu	Fuse seat	10*38	2	
E3101025	FU	Fuse	10*38*6A	2	
E0701016 E0209001	KT1	Timer Relay	LC1D09F7 110V 4A+LA3DRO	1	0.1~3 sec
E0701016	KT2	Magnetic Contact	LC1D09F7 110V 4A	1	
E0701016 E0210001	KT3	Timer Relay	LC1D09F7 110V 4A+LA2DTO	1	0.1~3 sec

Part No.	Symbol	Name	Specification	Q'ty	Remark
E1202045	SB1	Emg. Rush Button	XB2BS544C-R-2B	1	
E1202046	SB2	Push Button	XB2BA23C-2A	1	
E1202003	SB3	Push Button	YK22ΦYK110V green 1A1B	1	
E1202001	SB3	Push Button	YK22Φ24V green 1A1B	1	Optional
E1202046	SB4	Push Button	XB2-BA23C-2A	1	
E1202046	SB5	Push Button	XB2-BA23C-2A	1	
E1202046	SB6	Push Button	XB2-BA23C-2A	1	
E1202046	SB7	Push Button	XB2-BA23C-2A	1	
E0901006	SB8	Micro Switch	1309	1	Optional
E1302004	SS1	Change Over Button	YK22Φ 1A1B (B)	1	
E1302035	SS2	Selector switch	SKB2+BD34	1	
E1202040	SS2	Selector switch	SKB2-BE102-1B	2	
E3501002	SS3	Power Supply	S-50-24	1	
E0303010	X1	Terminal block	4p 50A	1	
E0303015	X2	Terminal block	Ta020*40P	1	
M0302018	SOL1 \ SOL2	Solenoid Valve	DSG-02-3C2 110V	1	
M0302018	SOL3 \ SOL4	Solenoid Valve	DSG-02-3C2 110V	1	
M0302018	SOL5 \ SOL6	Solenoid Valve	DSG-02-3C2 110V	1	
M0302019	SOL1 \ SOL2	Solenoid Valve	DSG-02-3C2 24V	1	
M0302019	SOL3 \ SOL4	Solenoid Valve	DSG-02-3C2 24V	1	
M0302019	SOL5 \ SOL6	Solenoid Valve	DSG-02-3C2 24V	1	
E0901042	SQ0	Limit Switch	9208	1	
E0901042	SQ1	Limit Switch	9208	1	
E0901007	SQ2	Micro Switch	1704	1	
E0901007	SQ3	Micro Switch	1704	1	
E1701001	WL	Work Lamp	A-L301C 24V/20W	1	
E0703009 E0209001	KT1	Timer Relay	LC1D09B7 AC24V+LA3 DRO	1	
E0703009	KT2	Magnetic Contact	LC1D09B7 AC24V	1	
E0703009 E0210001	KT3	Timer Relay	LC1D09B7 AC24V+LA3 DTO	1	
		Spindle Motor	Vertical 10HP 4P 3PH	1	
		Ascending/ Descending Motor	Vertical 5HP 4P 3PH	1	
		Hydraulic Motor	Vertical 1HP 4P 3PH	1	
		Cooling Motor	1/4HP 2P	1	

Annex4 Electrical Main Parts list (for RD-2500 CE Standard)

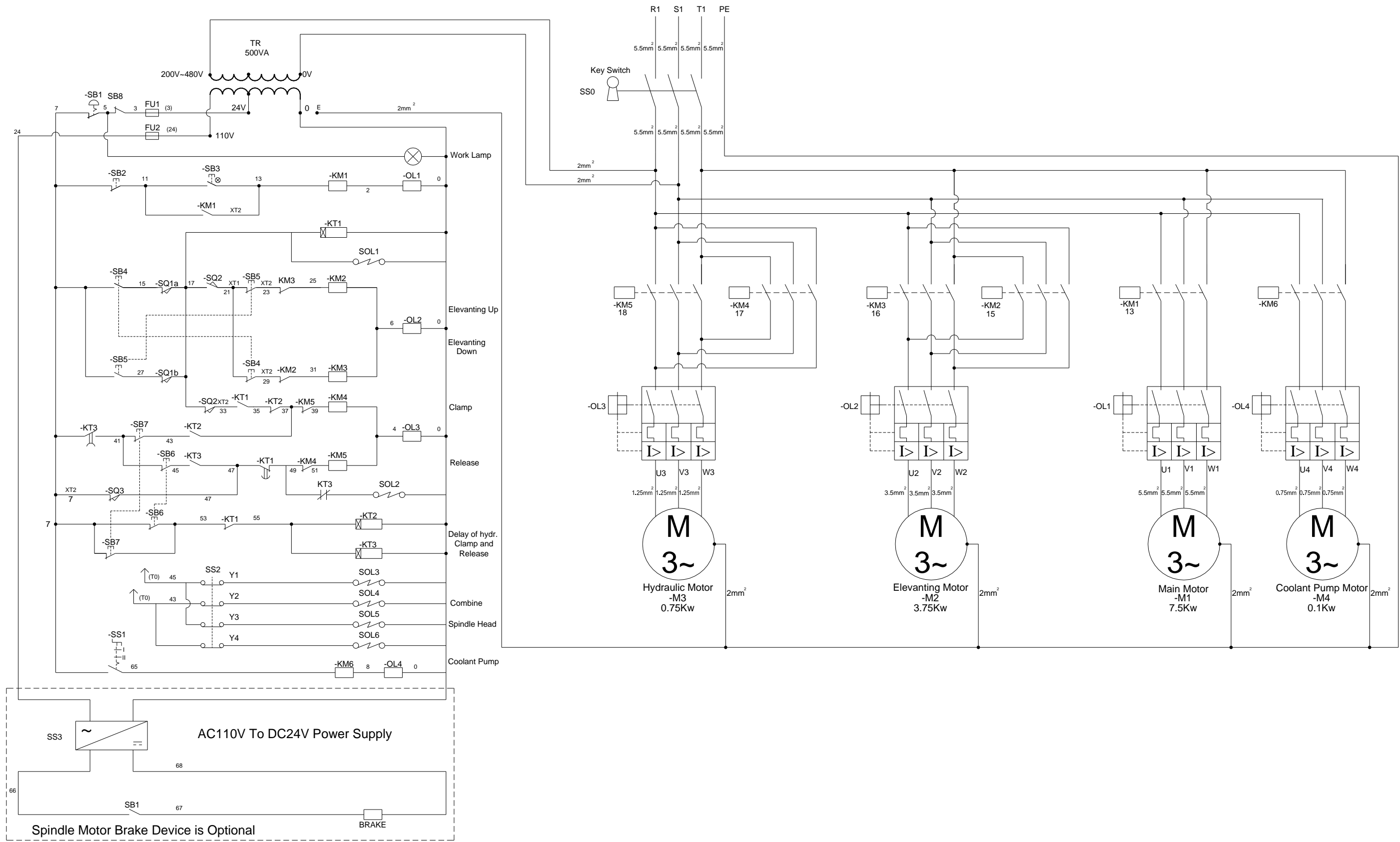

Annex5 Electrical Main Parts list (TPR-C2500 CE Standard)

Part No.	Symbol	Name	Specification	Q'ty	Remark
2E1625007 2E1630001 2E1630002	SS0	Key Switch	NZMB1-A32A NZM1*TVPNA NZM1/2-XV4	1	For 380~480V UL/CSA Optional
2E1625017 2E1630001 2E1630002	SS0	Key Switch	NZMB1-A50 NZM1*TVPNA NZM1/2-XV4	1	For 200~240V UL/CSA Optional
E0703006	MS1	Magnetic Contact	CU27 24V	1	
E0703005	MS2	Magnetic Contact	CU18 24V	1	
E0703005	MS3	Magnetic Contact	CU18 24V	1	
E0703004	MS4	Magnetic Contact	CU11 3a1b 24V	1	
E0703004	MS5	Magnetic Contact	CU11 3a1b 24V	1	
E0703004	MS6	Magnetic Contact	CU11 3a1b 24V	1	
E0207061	OL1	Over load relay	RHU-80Kz 24.5~36A	1	For 200~240V
E0207058	OL2	Over load relay	RHU-10 15~20A	1	For 200~240V
E0207054	OL3	Over load relay	RHU-10 3.5~4.8A	1	For 200~240V
E0207050	OL4	Over load relay	RHU-10/1.1~1.6		For 200~240V
E0207059	OL1	Over load relay	RHU-80Kz 17~25A	1	For 380~280V
E0207056	OL2	Over load relay	RHU-18 9~12.5A	1	For 380~480V
E0207053	OL3	Over load relay	RHU-10 1.8~2.5A	1	For 380~480V
E0207049	OL4	Over load relay	RHU-10/0.55~0.8	1	For 380~480V
	PT	Transformer	500VA 1:0,220,380,415,440V 2:0,24,110V	1	optional
E3101019	Fu1 \ Fu2	Fuse seat	10*38	2	UL/CSA optional
E2802109	Fu1 \ Fu2	Fuse seat	10*38	2	
E3101043	Fu1	Fuse	10*38*6A	1	UL/CSA optional
E3101039	Fu2	Fuse	10*38*2A	1	UL/CSA optional
E3101025	Fu1	Fuse	10*38*6A	1	
E3101022	Fu2	Fuse	10*38*2A	1	
E0703009 E0209001	KT1	Timer Relay	LC1D09B7 24V+LA3DRO	1	0.1~3 sec
E0703009	KT2	Timer Relay	LC1D09B7 24V	1	
E0703009 E0210001	KT3	Timer Relay	LC1D09B7 24V+LA2DTO	1	0.1~3 sec
E1618002	SB1	Emg. Rush Button	XB4-BS542	1	UL/CSA optional
E1202019 E1202025	SB2	Push Button	ZB4-BA1+ZB4-BZ102	1	UL/CSA optional
E1202001	SB3	Push Button	YK22Φ 24V green	1	
E1202022 E1202020	SB4	Push Button	ZB4-BA2+ZB4-BZ105	1	UL/CSA optional
E1202022 E1202020	SB5	Push Button	ZB4-BA2+ZB4-BZ105	1	UL/CSA optional

Part No.	Symbol	Name	Specification	Q'ty	Remark
E1202022 E1202020	SB6	Push Button	ZB4-BA2+ZB4-BZ105	1	UL/CSA optional
E1202022 E1202020	SB7	Push Button	ZB4-BA2+ZB4-BZ105	1	UL/CSA optional
E0901006	SB8	Limit Switch	1309	1	Optional
E1401020 E0403029	SS0	Key Switch	EZAROTE 3P30A100B	1	For 380~480V Optional CE
E1401020 E0403011	SS0	Key Switch	EZAROTE 3P50A100B	1	For 200~240V Optional CE
E1302004	SS1	Selector switch	YK22Φ 1A1B(B)	1	
E1302022 E1302023	SS2	Selector switch	ZB4-BD3+ZB4-BZ104	1	UL/CSA optional
E1202024	SS2	Selector switch	ZBE-102	2	UL/CSA optional
E3501002	SS3	Power supply	S-50-24	1	Optional
		Spindle Motor	Vertical 10HP 4P 3PH	1	
		Ascending/ Descending Motor	Vertical 5HP 4P 3PH	1	
		Hydraulic Motor	Vertical 1HP 4P 3PH	1	
		Cooling Motor	1/4HP 2P	1	
E0303017	X1	Terminal block	AVK-16 * 3P	1	
E0303018	X1	Terminal block	AVK-35*1P	1	
E0301003	X2	Terminal block	WG260 -311*18P	1	
E0301001	X2	Terminal block	WG260 -346*13P	1	
E0301039	X3	Terminal block	AKV6*3P	1	
E0301034	X3	Terminal block	AKV4*9P	1	
E0901042	SQ0	Limit Switch	9208	1	
E0901042	SQ1	Limit Switch	9208	1	
E0901007	SQ2	Micro Switch	1704	1	
E0901007	SQ3	Micro Switch	1704	2	
E1701001	WL	Work Lamp	A-L301C 24V/20W	1	
M0302019	SOL1 \ SOL2	Solenoid Valve	DSG-02-3C2 24V	1	
M0302019	SOL3 \ SOL4	Solenoid Valve	DSG-02-3C2 24V	1	
M0302019	SOL5 \ SOL6	Solenoid Valve	DSG-02-3C2 24V	1	
E1202045	SB1	Emg. Rush Button	XB2BS544C-R-2B	1	
E1202046	SB2	Push Button	XB2BA23C-2A	1	
E1202046	SB4	Push Button	XB2BA23C-2A	1	
E1202046	SB5	Push Button	XB2BA23C-2A	1	
E1202046	SB6	Push Button	XB2BA23C-2A	1	
E1202046	SB7	Push Button	XB2BA23C-2A	1	
E1302035	SS2	Selector switch	SKB2+BD34	1	
E1202040	SS2	Selector switch	SKB2-BE102-1B	2	
E0901006	SB7	Micro Switch	1309	1	Optional