

# CHAPTR 9 Annex

## 9.1 Electrical circuit diagram (For RD-1230H CE Standard)

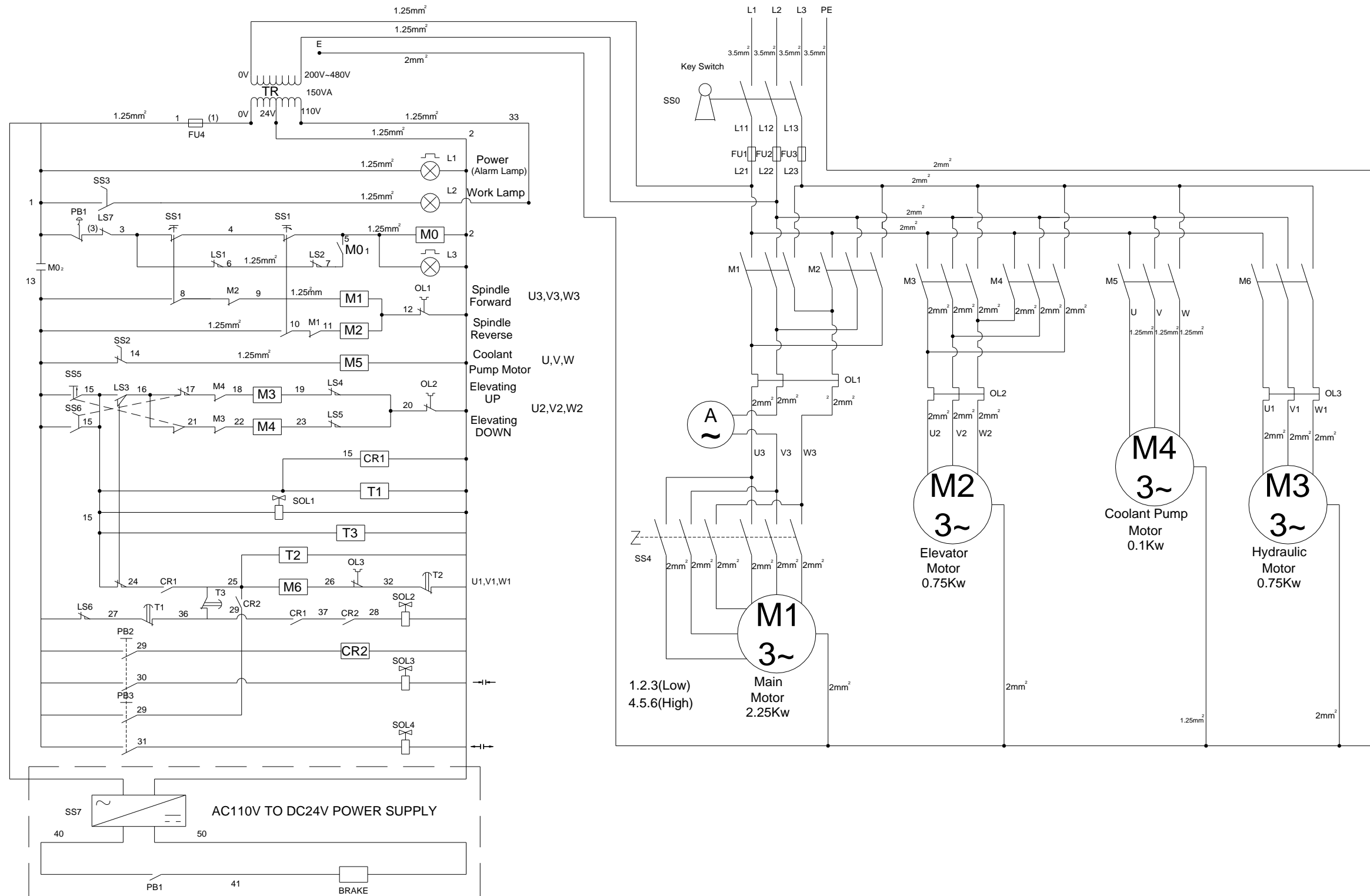

(Spindle Motor Brake Device is Optional)

**9.2 Electrical circuit diagram  
(For RD-1230 CE Standard)**

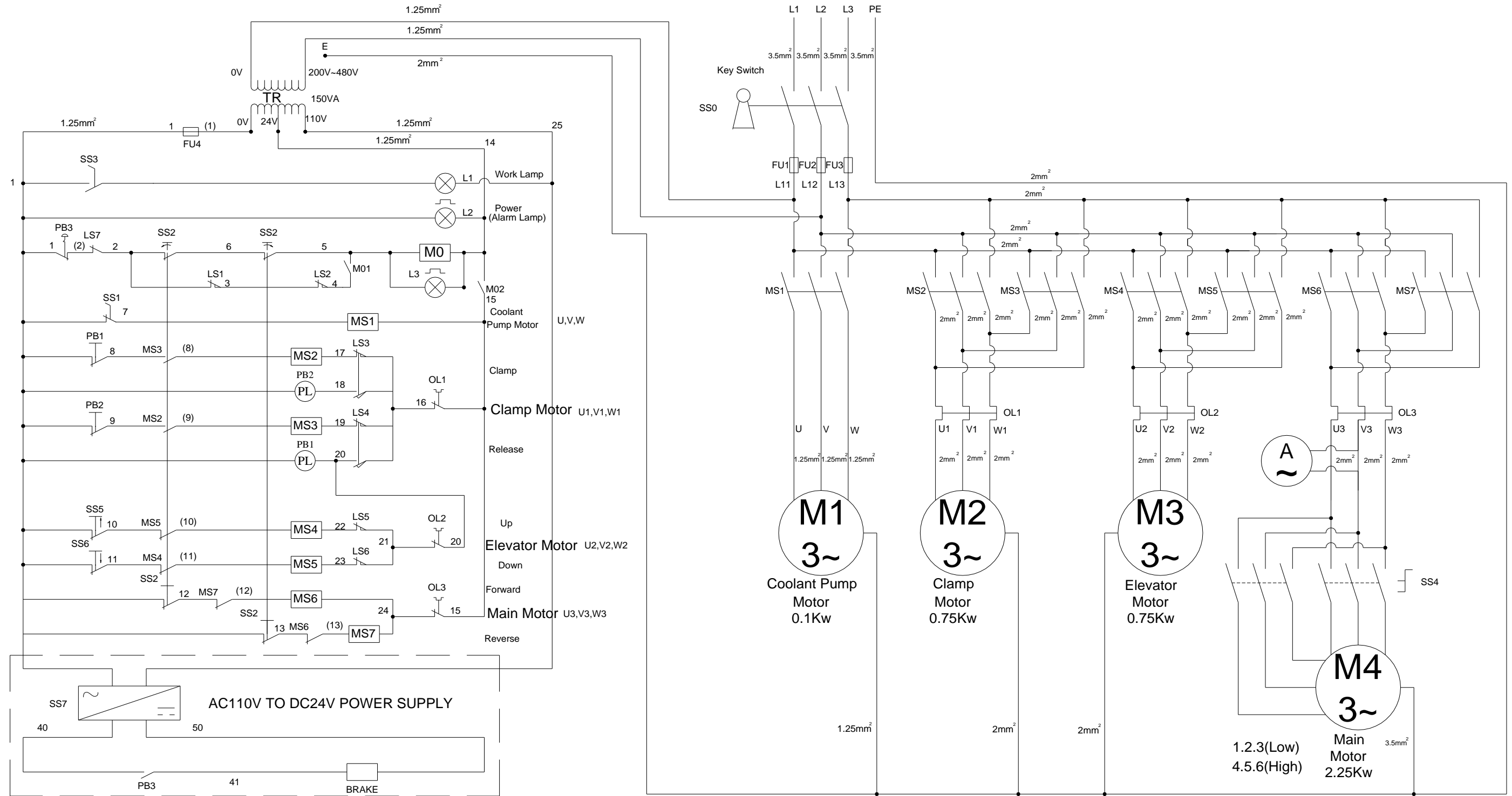

(Spindle Motor Brake Device is Optional)

**9.3 Electrical circuit diagram  
(For RD-1600H CE Standard)**

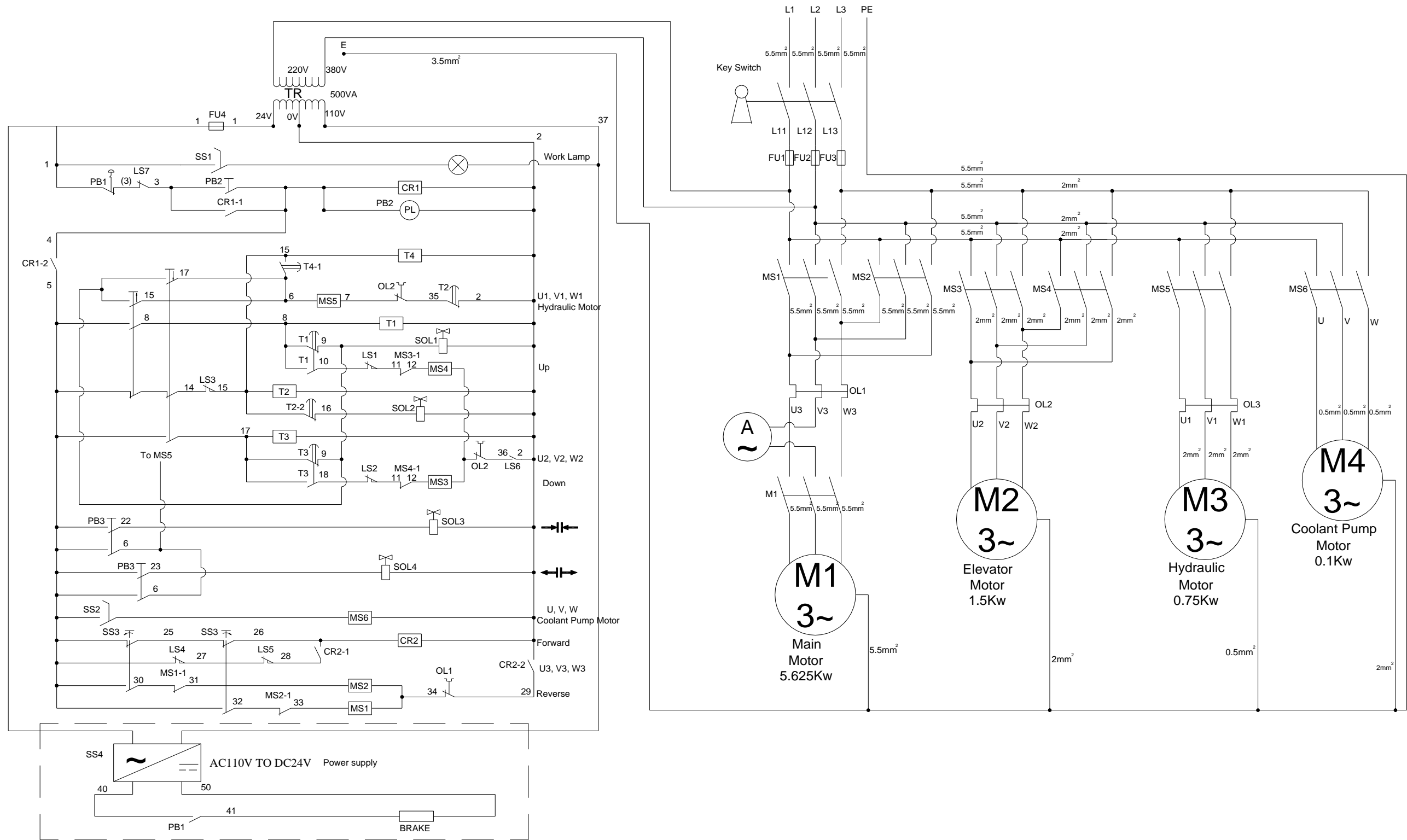

(Spindle Motor Brake Device is Optional)

**9.4 Electrical circuit diagram  
(For TPR-2000H CE Standard)**

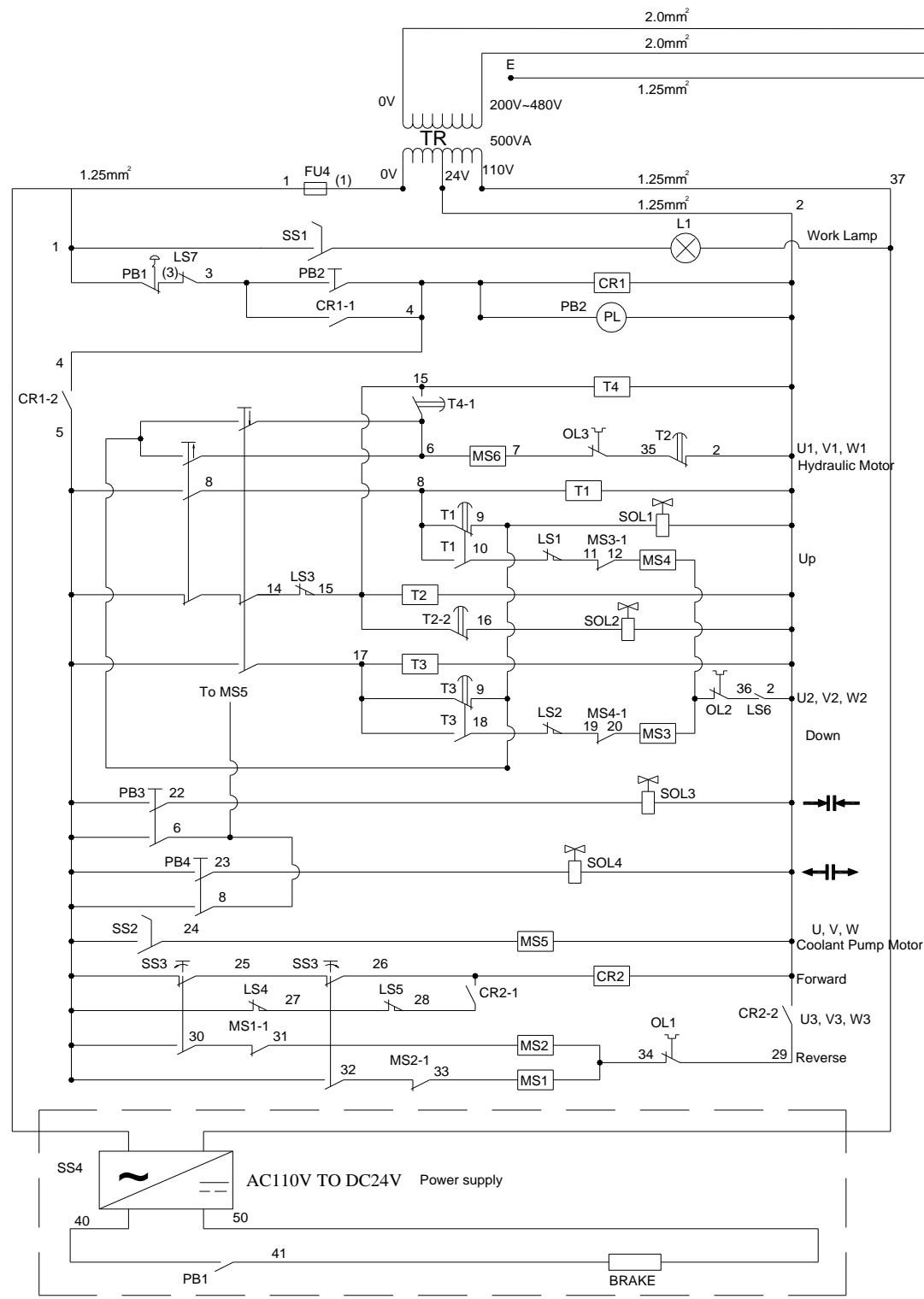

(Spindle Motor Brake Device is Optional)

