



---

## **HIGH SPEED PRECISION LATHE**

# **OPERATOR'S & SPARE PARTS MANUAL**

16" & 18" Series

**For Models : 1640L, 1660L, 1860L, 1880L**

Sharp Industries, Inc.  
3501 Challenger Street  
Torrance, CA 9050. USA  
Tel (310) 370-5990, Fax (310) 542-6162

# CONTENTS

<b>PREFACE</b> .....	3
<b>1. SHARP HIGH SPEED PRECISION LATHE</b>	
1-1 Machine Assembly .....	5
<b>2. UNPACKING &amp; MACHINE INSTALLATION</b>	
2-1 Unpacking.....	7
2-2 Lifting.....	7
2-3 Basic Foundation .....	8
2-4 Cleaning .....	8
2-5 Leveling Adjustment .....	8
<b>3. ELECTRICAL CIRCUIT CONTROL</b>	
3-1 Electrical Wiring .....	9
3-2 Electrical Equipment.....	9
3-3 Electrical Cautions.....	9
<b>4. TESTING &amp; OPERATION</b>	
4-1 Operation Symbols .....	10
4-2 Transmission & Stop of Spindle .....	11
4-3 Spindle Speed Selection .....	11
4-4 Intermittent Operation of Spindle.....	12
4-5 The Importance and Methods of Spindle Leveling Adjustment.....	13
4-6 Transmission & Stop of Gear Box .....	14
4-7 Gear Box Operation .....	14
4-8 Manual Operation .....	14
4-9 Automatic Feeding Operation .....	15
4-10 Automatic Feeding Stop Operation.....	15
4-11 4 Position Automatic Feeding Stop Operation.....	15
4-12 Tailstock Operation .....	16

# CONTENTS

## 5. THREADING

5-1 Leadscrew Drive .....	17
5-2 Threading .....	17
5-3 Thread Dial Indicator .....	17
5-4 Thread & Feed Chart.....	19
5-5 Module & D.P. Thread Chart .....	22

## 6. LUBRICATION

6-1 Headstock Lubrication .....	24
6-2 Gear Box & Apron Lubrication .....	24
6-3 Lubrication Charts .....	24
6-4 Lubrication Locations .....	25

## 7. MAINTENANCE & ADJUSTMENT

7-1 Headstock .....	26
7-2 Apron & Saddle .....	27
7-3 Gear Box.....	28
7-4 Tailstock Center Line Adjustment .....	28
7-5 Belt Tension Adjustment.....	29
7-6 Brake Belt Adjustment.....	29
7-7 Brake & Limit Switch Adjustment.....	30
7-8 Leadscrew Backlash Adjustment.....	30
7-9 Cutting Coolant Pump.....	30

## 8. TAPER ATTACHMENT .....

31

# PREFACE

Thank you for choosing Sharp as your choice for a high precision lathe. We at Sharp take pride in the workmanship, durability and precision of our machines.

Read this manual in its entirety in order to get the best possible results from the machine and prolong its life, and become familiar with its operation, safety features and recommended maintenance.

The 1 year warranty would be void if the machine was damaged due to improper use or disregard to any operational instruction contained in this manual.

Some precautions to be taken not listed later in this manual are:

1. Do **NOT** install the machine in direct sunlight or directly in front of any cooling system blowers.
2. Use only recommended lubricants.
3. Always keep machine clean.
4. Should the ways become damaged do not move the carriage until they have been repaired.



**Read the following instructions before operating the machine.**

- ◆ Only authorized personnel should work on this machine. Untrained personnel present a hazard to themselves and the machine, and improper operation will void the warranty.
- ◆ Check for damaged parts and tools before operating the machine. Any part or tool that is damaged should be properly repaired or replaced by authorized personnel. Do not operate the machine if any component does not appear to be functioning correctly.
- ◆ Use appropriate eye and ear protection while operating the machine. ANSI-approved impact safety goggles and OSHA-approved ear protection are recommended to reduce the risks of sight damage and hearing loss.
- ◆ The Emergency Stop button is the large, circular red switch located on the Control Panel. Pressing the Emergency Stop button will instantly stop all motion of the machine.
- ◆ The electrical panel should be closed and the key and latches on the electrical cabinet should be secured at all times except during installation and service. At those times, only qualified electricians should have access to the panel. When the main circuit breaker is on, there is high voltage throughout the electrical panel. Once the machine is installed, the electrical cabinet must be locked and the key available only to qualified service personnel.
- ◆ DO NOT modify or alter this equipment in any way. If modifications are necessary, all such requests must be handled by SHARP INDUSTRIES, INC. Any unauthorized modification or alteration of any sharp MACHINES could lead to personal injury and/or mechanical damage and will void your warranty

# 1. SHARP HIGH SPEED PRECISION LATHE

## 1-1 Machine Assembly

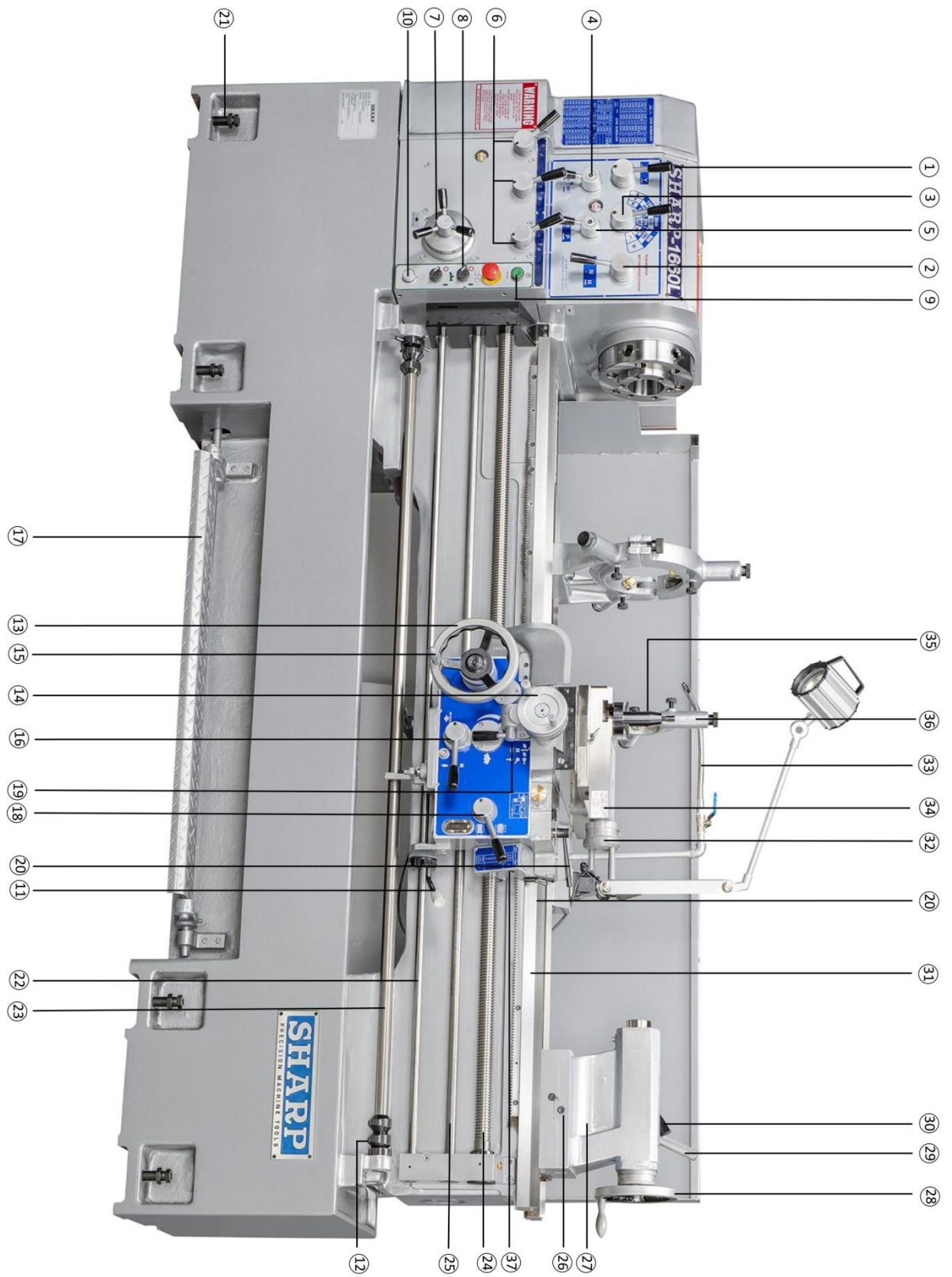

<b>ITEM</b>	<b>DESCRIPTION</b>	<b>ITEM</b>	<b>DESCRIPTION</b>
1	Spindle speed shifting lever	20	Carriage clamping lever
2	Spindle speed H/L shifting lever	21	Foundation adjusting bolt
3	Spindle speed shifting selection lever	22	Spindle operation control rod
4	Forward/Reverse Shifting lever	23	4 position automatic feed stop selection rod
5	Thread/Feed Selection lever	24	Leadscrew
6	Thread/Feed Shifting lever	25	Auto-feed rod
7	10-step feed selection dial	26	Tailstock set over adjusting Screw
8	Power source switch (Main switch)	27	Tailstock body
9	Intermittent button	28	Tailstock handwheel
10	Coolant supply button	29	Tailstock body Clamping lever
11	Spindle operation control lever	30	Tailstock spindle locking lever
12	Adjustable trip dog	31	Rack
13	Longitudinal feed hand wheel	32	Compound rest handle
14	Cross slide handle	33	Coolant control valve
15	Trip plunger	34	Compound rest
16	Auto feeding engaged lever	35	Four way tool post
17	Foot brake pedal	36	Tool post clamping lever
18	Half nut engaged lever	37	Thread dial indicator
19	Feed axis selector		

## 2. UNPACKING & MACHINE INSTALLATION

### 2-1 Unpacking

When the machine is arrived, first, check if the wooden case is damaged or not, secondly, open the case and inspect the machine for any damage or short supply of parts. If so, please contact our company or insurance company immediately in order to get the best solution or refund; otherwise our company or the insurance company will not be in the position to compensate for the damage.

### 2-2 Lifting

Please refer to figure 2-2 for machine unloading from the truck.

The steps of lifting the lathes are:

1. Clamp the bedways with a special made hanger, which consists of clamp and an iron chain.
2. Raise the lathe a little bit with crane, then check if the lathe is balanced. If not, move apron and cross slide back or forth to make the machine is balanced.
3. While the machine arrives at the location, put down the machine slowly to avoid any inaccuracy of the machine caused by bumps or crash.
4. For adjusting the electrical cabinet, the machine should be located allowing sufficient area, min. over 600mm from wall at back and tailstock end.



Fig.2-2

### 2-3 Basic Foundation

With the common usage of tungsten carbide cutting tools nowadays, heavy cutting and quicker spindle speed are therefore reinforced. This may cause the vibration easily. In order to keep the best cutting condition it is necessary to build a sound & good floor basis. (Please refer to figure 2-3 for basic structure.)

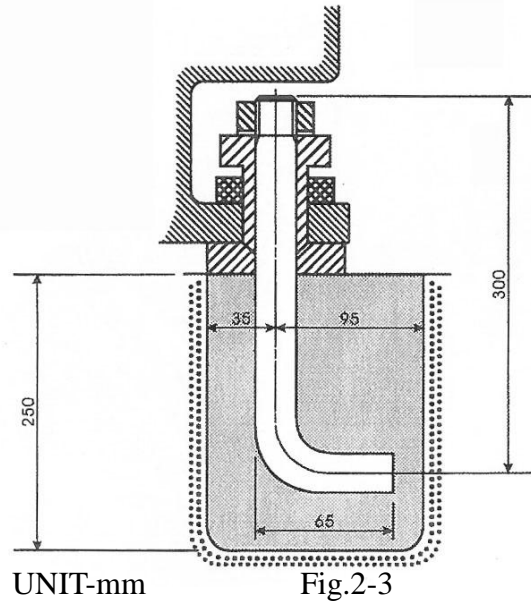

### 2-4 Cleaning

The machine is protected with a special anti-rust agent before delivery. Before operating the machine, clean all parts, especially the slideways, leadscrew, rack and all bright surfaces with soft brush/cloth soaked with cleaning solvent or kerosene. Do NOT use gasoline or cellulose solvent to avoid dangers or fire or explosion. After removing the anti-agent, keep the machine properly lubricated. Then turn the moving mechanism like tool post, tailstock by hand back & forth within their moving areas.

### 2-5 Leveling Adjustment

Once the set screw and concrete are completely dried and fixed. It is time to adjust the level of the bedway. A machinist's level (accuracy 0.02mm/1000mm) should be placed on the slideways of bed. Adjust the set screw for longitudinal direction of bed level. For transverse direction of bed level, tight the nuts until the accuracy is within 0.04mm/1000mm. Then check again. If the deviation is resulted from the nuts, it is necessary to make another adjustment. (See Figure 2-5)

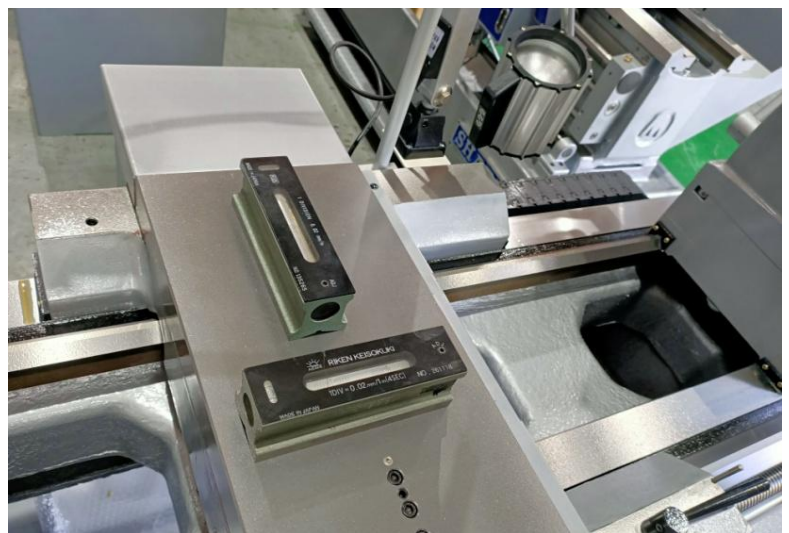

Fig.2-5



### 3. ELECTRICAL CIRCUIT CONTROL

#### 3-1 Electrical Wiring

The electrical control box can be found by opening its cover at the back side of bed. Connect the power source wire with the connecting points (R.S.T).

The wire between the power source and the connecting points must be over sectional area  $8\text{mm}^2$  ( $5.5\text{mm}^2$  for 460 or 18" series).

The main switch between machine and power source should be equipped with safety fuse. Besides, the machine must have a earth wire.



Fig.3-1

#### 3-2 Electrical Equipment













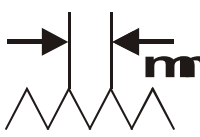

1. The electrical control box is also equipped with overload circuit breaker and electric magnetic contactor to protect motor from burning out by overload.
2. The main switch is connected with a micro switch.
3. The foot brake is connected with micro switch. Stepping the footbrake is quicker to stop the lathe than turning off the switch. The spindle can only revolute again by re-operating the spindle operation control lever using the foot brake.
4. The spindle will rotate continuously as long as the intermittent switch on the top of the electrical panel is pressed.

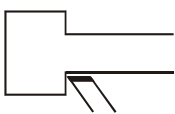
#### 3-3 Electrical Cautions

After wiring, check the rotation of the spindle. Turn the main switch “ON” and make sure the safety of spindle. Then push intermittent button ① momentarily. The correction direction of the spindle rotation is counter clockwise. (looking from tailstock for a downward movement of the spindle operation control lever.) Wrong direction of rotation can be rectified by interchanging any two of the three phase lines (R.S.T.) in the power source.

## 4. TESTING & OPERATION

### 4-1 Operation Symbols

1	<b>HIGH</b>	High speed revolution	11		Variable adjustment (pressure) <b>Clockwise:</b> pressure increase <b>Counterclockwise:</b> pressure decrease
2	<b>LOW</b>	Low speed revolution	12		Electrical control box
3		Forward revolution	13		Imperial threads
4		Neutral gear	14		Metric threads
5		Reverse revolution	15		Auto feeding Rate per revolution
6		Feeding	16		Pump
7		Intermittent button	17		Power switch-ON
8		Cross feeding	18		Power switch-OFF
9		Longitudinal feeding	19		Oil inlet (hole)
10		Cone clutch			

## 4-2 Transmission & Stop of Spindle

After the procedure described previously in this manual have been done, it is time to test the machine.

Position the spindle H/L shifting lever ② to “L”, the spindle speed shifting selection lever ③ to the very left side, and forward/reverse shifting lever ④ to “N” position. Lift the spindle operation control lever (⑪ of item 1-1), the spindle will rotate forward, press down the lever, the spindle will rotate reverse; in ‘Neutral’ position, the spindle will stop. For normal forward & reverse revolution, always operate the spindle operation control lever. For emergency stop, step on the foot brake, the spindle operation control lever should push back to ‘Neutral’ position after stepping the foot brake. Afterward, start the spindle.

Turn the coolant supply button (⑩ of item 1-1). Adjust the adjusting valve for the required coolant flow.

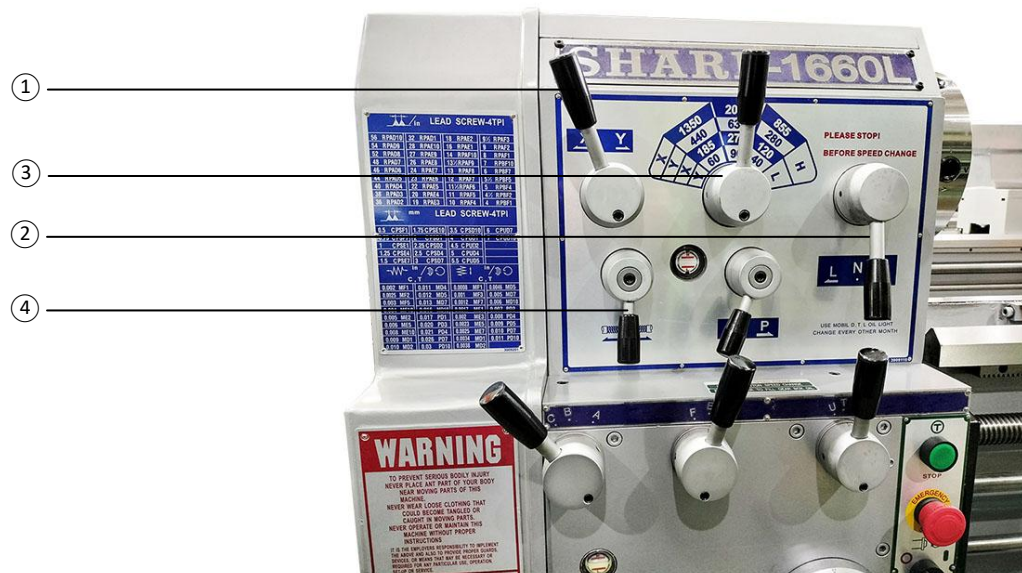

Fig.4-2

## 4-3 Spindle Speed Selection

Spindle speed shift is made up of three speed shifting levers:

1. Spindle speed shifting lever
2. Spindle speed H/L shifting lever
3. Spindle speed shifting selection lever for total of 12 spindle speed numbers

Put the spindle speed H/L shifting lever to ‘neutral’ gear between ‘H’ and ‘L’ rotate the spindle by hand.

For safety and protecting the gears from damage, only change speeds when the motor is completely stopped. If the gears are not easily engaged, press intermittent button and handle the speed shifting levers to change the speeds.



**Caution:** Do not shift gears while spindle is turning. Be certain gears are properly engaged before starting.

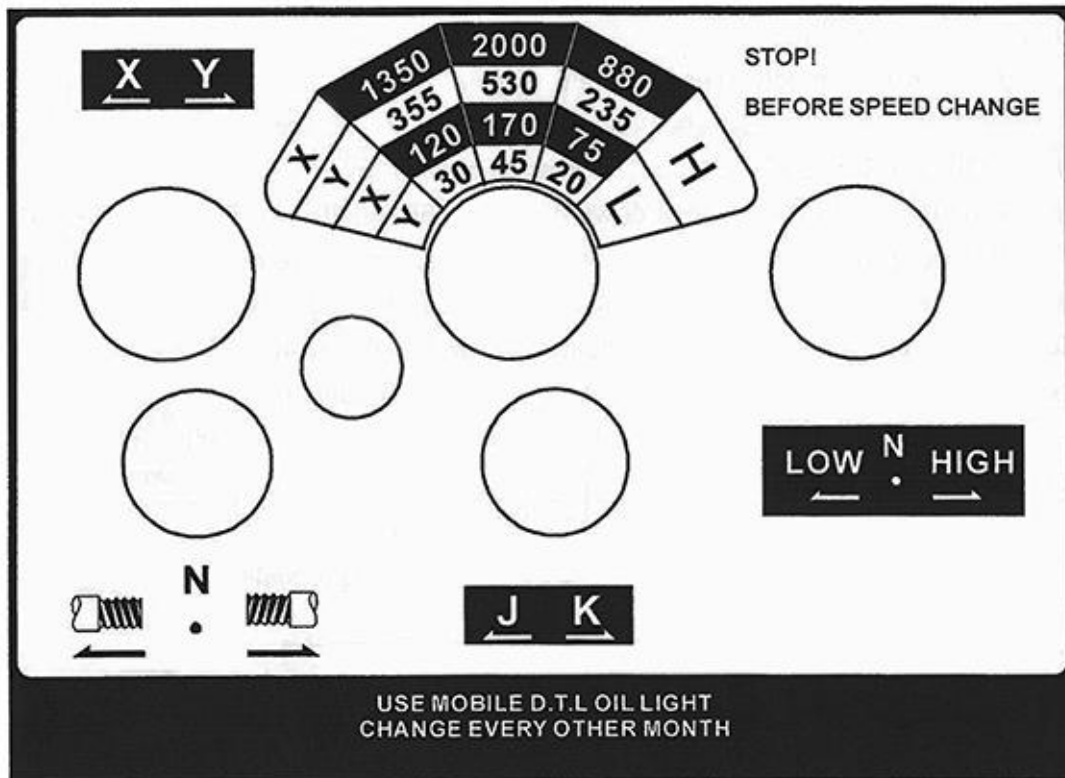

#### 4-4 Intermittent (Inching) Operation of Spindle

For the convenience spindle speed shifting, feeding rate recognition and work piece center line and adjustment, press the intermittent button ⑨ located on the right side of the gear box, and the spindle will rotate forward. The spindle will rotate as long as the intermittent switch is pressed. The intermittent switch cannot rotate reverse.



Fig.4-4

#### 4-5 The Importance and Methods of Spindle Leveling Adjustment

1. A lathe without proper leveling adjustment is likely to chatter. As a consequence, this will influence the cutting accuracy of work piece and result in poor roundness accuracy and finish. It is necessary to pay attention to the spindle leveling from time to time in order to have the best cutting condition of the lathe. Belt, 3-jaw chuck and the accumulative tolerances of parts on headstock, all such factors, can make the lathe chatter. To get rid of those problems, our lathe is especially designed to be equipped with leveling blocks mounted on the locking nut at the rear side of the spindle. The leveling blocks can be properly adjusted according to different condition. Please refer to following description & figure for proper adjustment.
2. First, set up the spindle speed at 1350 rpm. Put the palm on left hand of the headstock cover and press the switch by left hand. Then switch on the lathe to make the spindle turn. Move the leveling block "A & C" left or right by hand feeling until obtain the best leveling position. Then also move the leveling block "B" left or right till the best position with same way. Adjust repeatedly till your hand feels no chattering. Afterwards, change the spindle speed to 2000rpm or 880rpm and check the leveling in the same way as we did at 1350rpm. Finally, for the leveling block set screw a, a', b, b. c.c. securely.

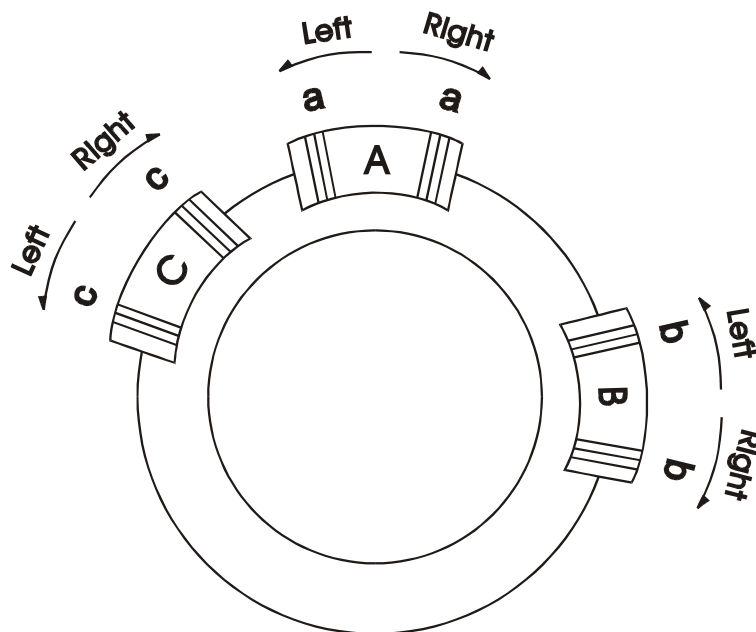

#### 4-6 Transmission & Stop of Gear Box

Open the end cover to find the gear train transmitting from headstock box, position the forward/reverse shifting lever (④ of item 1-1) to right side, the spindle will rotate forward; to right; reverse; to Neutral, stop. Do not change the gears while turning.

#### 4-7 Gear Box Operation

##### 1. Threading:

With the special design, there is no need to re-arrange the back gears for threading. Please refer to the ‘threading & feeding table’ and handle the thread/feed selection lever (⑤ of item 1-1), thread, feed shifting lever (⑥ of item 1-1) and 10-step feed selection dial (⑦ of item 1-1) accordingly.

##### 2. Auto feeding:

Also select the appropriate auto feeding rate by positioning the thread, feed selection lever (⑤ of item 1-1), thread, feed shifting lever (⑥ of item 1-1) and 10-step feed selection dial (⑦ of item 1-1) as indicated on the ‘threading and feeding table’.

#### 4-8 Manual Operation

First, position both the halt nut engage lever ⑱, and forward and reverse shifting lever (④ of item 1-1) to ‘N’ position to operate the apron handwheel ⑬ cross slide handle ⑭, and compound rest handle ⑳ easily.

It feeds 17mm per revolution of apron handwheel. The dials on cross slide and compound rest is graduated 0.02mm per calibration, and feeds 4mm per revolution.

The tool post can be rotated clockwise after loosening the tool post clamping lever (⑳ of item 1-1). Then position and tighten the clamping lever. For fixing the apron, just handle the saddle clamping lever ⑳. For cross slide and compound rest, screw tightly the set screws beside the taper pin.

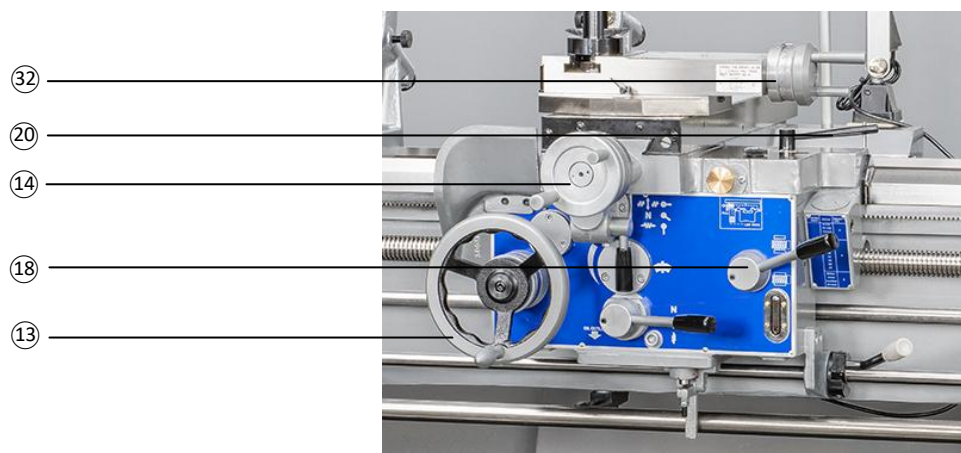

Fig.4-8

#### 4-9 Automatic Feeding Operation

1. Position the thread/reverse shifting lever (④ of item 1-1) for obtaining the required feeding position.
2. Shift the thread, feed selection lever (⑤ of item 1-1), thread, feed selection lever (⑥ of item 1-1), 10-step feed selection lever to select the appropriate feeding rate.
3. For threading, push the half nut engaged lever (⑱ of item 1-1) downward till fully engaged.
4. For cross feeding, push the feed axis selector (⑲ of item 1-1) downward till fully engaged.
5. For longitudinal feeding, pull the feed axis selector.

#### 4-10 Automatic Feeding Stop Operation

The apron is equipped with automatic stop device. Tighten the screw on the top of the adjustable trip dog ⑫, and then fix it to the required position. Be careful that the top tip of the adjustable trip dog can be set onto the required position for forward and backward feeding. To avoid danger or damage to work piece, always have a test before starting.



Fig.4-10

#### 4-11 4-position Automatic Feeding Stop Operation

To process certain length or step type of work piece, can use the 4-position Automatic feeding stop for length set cutting.

1. Rotate the adjustable trip dog (⑫ of item 1-1) to the required setting position and make the top tip of the adjustable trip dog face outward. Try to test the auto feeding and adjust the front and back position of the adjustable trip dog if required, in order to ascertain the position setting accuracy.
2. Secondly, operate the 4-position automatic feed stop selection lever to the according to second adjustable trip dog by hand and fix the adjustable trip dog according to above procedure.
3. Same procedure for the third and fourth adjustable trip dog.
4. While the apron is auto-feeding, only the top tip of adjustable trip dog, which faces outward can touch the trip plunger (⑮ of item 1-1). After stopping the auto feeding of apron, the other three adjustable trip dog can pass freely without any function.

#### 4-12 Tailstock Operation

1. The tailstock handwheel dial is divided in 0.002mm per graduation. The tailstock moves forward 5mm per clockwise revolution of handwheel. When revolving clockwise, the quill will retract and, to the last, the center will release automatically.
2. Push the tailstock quill locking lever ③① forward to fix the tailstock quill. For fixing the tailstock onto the bedway, push tailstock body clamping lever ②⑨ forward.
3. Adjust the centerline of the tailstock by loosening the tailstock set-over adjusting screw ②⑥ on the side firstly, then adjust the screw on the other side. After adjustment, tighten the screw on both sides.

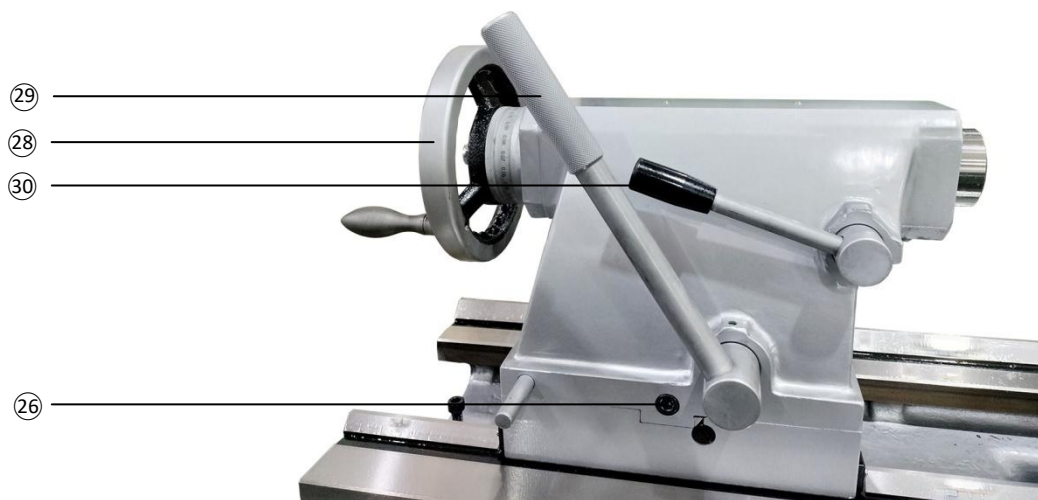

Fig.4-12

## 5. THREADING

### 5-1 Leadscrew Drive.

Move the forward/reverse lever (④ of item 1-1) to the right will cause the leadscrew to rotate backwards, moving the lever to the left the leadscrew will rotate forward and when lever is in neutral the leadscrew will stop.

### 5-2 Threading

1. After selecting the thread to be cut, set the following levers to the appropriate position: ⑤, ⑥ & ⑦ of item 1-1. (Example 18 t.p.i. PAE2)
2. Turn of the lathe.
3. Engage the half nut by pushing ⑱ of item 1-1 down, making sure it is fully engaged.

### 5-3 Thread Dial Indicator

1. Thread dial indicator for Imperial leadscrew

To cut even number threads the leadscrew can be engaged on any number of line. For odd number threads the leadscrew can be engaged on any number. Fractional threads (1/2, 1/4 etc.), leadscrew can only be engaged on the same number or line.

**Note:** When cutting metric threads on a lathe with an Imperial leadscrew, be sure the half nut is engaged at all times. (If not, the thread will not repeat).

2. Thread dial indicator for Metric leadscrew cutting metric threads.

There are two dials, 2&7 division and 3&5 division for Metric leadscrew while using Metric thread dial indicator. Use 3&5 division dial for cutting pitches 1.25, 2.5, 5.0, 2.25, 4.5; for the rest threads use 2&7 division dial.

**Example 1 :** For cutting pitches 0.5, 0.75, 1.0, 1.5, 2.0, 3.0, 4.0, 6.0, use the 14T worm gear and the 2&7 division dial. The dial numbers at which the leadscrew nuts may be engaged are 7, that is, every division can be engaged by leadscrew nuts.

**Example 2 :** For cutting pitches 1.75, 3.5, 7.0 also use the same 14T worm gear and the 2&7 division dial. But the dial numbers at which the leadscrew nuts may be engaged on 2; number 1 and 2.

Gear teeth	Pitch		Dial division	Half nuts engaged number
11T	2.75	5.5	2	1
13T	3.25	6.5	2	1
14T	1.75	3.5	2	1,2
	7			
	0.5	0.75	7	1,2,3,4,5,6,7
	1	1.5		
	2	3		
	4	6		
15T	1.25	2.5	3	1,2,3
	5			
	2.25	4.5	5	1,2,3
18T	6.75		2	1,2

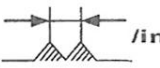
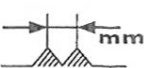
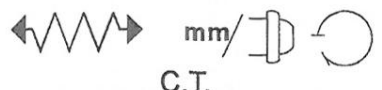
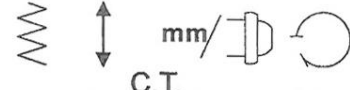

### 5-4 Thread & Feed Chart

For Swing 16" , 18" (410mm, 460mm) Series while Metric Leadscrew & Metric Feed.



				LEAD SCREW-P=6mm			
				R			
56	PAD10	32	PAD1	18	PAE2	9 1/2	PAF3
54	PAD9	28	PAE10	16	PAE1	9	PAF2
52	PAD8	27	PAE9	14	PAF10	8	PAF1
48	PAD7	26	PAE8	13 1/2	PAF9	7	PBF10
46	PAD6	24	PAE7	13	PAF8	6	PBF7
44	PAD5	23	PAE6	12	PAF7	5 1/2	PBF5
40	PAD4	22	PAE5	11 1/2	PAF6	5	PBF4
38	PAD3	20	PAE4	11	PAF5	4 1/2	PBF2
36	PAD2	19	PAE3	10	PAF4	4	PBF1
				LEAD SCREW-P=6mm			
				C			
0.5	PSF1	1.75	PSE10	3.5	PSD10	6	PUD7
0.75	PSF7	2	PSD1	4	PUD1	7	PUD10
1	PSE1	2.25	PSD2	4.5	PUD2		
1.25	PSE4	2.5	PSD4	5	PUD4		
1.5	PSE7	3	PSD7	5.5	PUD5		
							
0.05	MF1	0.30	MD4	0.02	MF1	0.15	MD5
0.06	MF2	0.34	MD5	0.03	MF3	0.17	MD7
0.08	MF5	0.37	MD7	0.04	MF7	0.20	MD10
0.10	MF10	0.42	MD10	0.05	ME1	0.24	PD2
0.13	ME2	0.48	PD1	0.06	ME3	0.27	PD4
0.17	ME5	0.54	PD2	0.07	ME5	0.30	PD5
0.21	ME10	0.60	PD4	0.08	ME7	0.34	PD7
0.24	MD1	0.74	PD7	0.1	MD1	0.40	PD10
0.27	MD2	0.82	PD10	0.12	MD2		

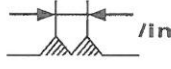
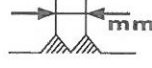

For Swing 16" , 18" (410mm, 460mm) Series while Imperial Leadscrew & Imperial Feed.

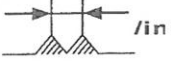
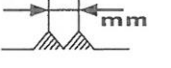

				LEAD SCREW - 4TPI			
				R			
56	PAD10	32	PAD1	18	PAE2	9 1/2	PAF3
54	PAD9	28	PAE10	16	PAE1	9	PAF2
52	PAD8	27	PAE9	14	PAF10	8	PAF1
48	PAD7	26	PAE8	13 1/2	PAF9	7	PBF10
46	PAD6	24	PAE7	13	PAF8	6	PBF7
44	PAD5	23	PAE6	12	PAF7	5 1/2	PBF5
40	PAD4	22	PAE5	11 1/2	PAF6	5	PBF4
38	PAD3	20	PAE4	11	PAF5	4 1/2	PBF2
36	PAD2	19	PAE3	10	PAF4	4	PBF1
				LEAD SCREW-P - 4TPI			
				C			
0.5	PSF1	1.75	PSE10	3.5	PSD10	6	PUD7
0.75	PSF7	2	PSD1	4	PUD1	7	PUD10
1	PSE1	2.25	PSD2	4.5	PUD2		
1.25	PSE4	2.5	PSD4	5	PUD4		
1.5	PSE7	3	PSD7	5.5	PUD5		
							
C.T.				C.T.			
0.002	MF1	0.011	MD4	0.0008	MF1	0.0046	MD5
0.0025	MF2	0.012	MD5	0.001	MF3	0.005	MD7
0.003	MF5	0.013	MD7	0.0012	MF7	0.006	MD10
0.004	MF10	0.016	MD10	0.0017	ME1	0.007	PD2
0.005	ME2	0.017	PD1	0.002	ME3	0.008	PD4
0.006	ME5	0.020	PD3	0.0023	ME5	0.009	PD5
0.008	ME10	0.021	PD4	0.0025	ME7	0.010	PD7
0.009	MD1	0.026	PD7	0.0034	MD1	0.011	PD10
0.010	MD2	0.03	PD10	0.0038	MD2		

For Swing 16" , 18" (410mm, 460mm) Series while Imperial Leadscrew but Metric Feed.

				LEAD SCREW – 4TPI			
				R			
56	PAD10	32	PAD1	18	PAE2	9 1/2	PAF3
54	PAD9	28	PAE10	16	PAE1	9	PAF2
52	PAD8	27	PAE9	14	PAF10	8	PAF1
48	PAD7	26	PAE8	13 1/2	PAF9	7	PBF10
46	PAD6	24	PAE7	13	PAF8	6	PBF7
44	PAD5	23	PAE6	12	PAF7	5 1/2	PBF5
40	PAD4	22	PAE5	11 1/2	PAF6	5	PBF4
38	PAD3	20	PAE4	11	PAF5	4 1/2	PBF2
36	PAD2	19	PAE3	10	PAF4	4	PBF1
				LEAD SCREW – 4TPI			
				C			
0.5	PSF1	1.75	PSE10	3.5	PSD10	6	PUD7
0.75	PSF7	2	PSD1	4	PUD1	7	PUD10
1	PSE1	2.25	PSD2	4.5	PUD2		
1.25	PSE4	2.5	PSD4	5	PUD4		
1.5	PSE7	3	PSD7	5.5	PUD5		
							
C.T.				C.T.			
0.05	MF1	0.29	MD4	0.02	MF1	0.14	MD5
0.06	MF2	0.32	MD5	0.03	MF3	0.16	MD7
0.08	MF5	0.35	MD7	0.04	MF7	0.18	MD10
0.10	MF10	0.40	MD10	0.05	ME1	0.2	PD1
0.13	ME2	0.45	PD1	0.06	ME3	0.24	PD2
0.16	ME5	0.52	PD2	0.07	ME5	0.28	PD5
0.20	ME10	0.58	PD4	0.08	ME7	0.32	PD7
0.23	MD1	0.70	PD7	0.1	MD1	0.36	PD10
0.26	MD2	0.80	PD10	0.12	MD2		

### 5-5 Module & D.P Thread Chart

For Swing 16" , 18" (410mm, 460mm) Series while Metric Leadscrew.

	 <b>LEAD SCREW-P=6mm</b>							
	R							
	56	PAD10	32	PAD1	18	PAE2	9 1/2	PAF3
	54	PAD9	28	PAE10	16	PAE1	9	PAF2
	52	PAD8	27	PAE9	14	PAF10	8	PAF1
	48	PAD7	26	PAE8	13 1/2	PAF9	7	PBF10
	46	PAD6	24	PAE7	13	PAF8	6	PBF7
	44	PAD5	23	PAE6	12	PAF7	5 1/2	PBF5
	40	PAD4	22	PAE5	11 1/2	PAF6	5	PBF4
	38	PAD3	20	PAE4	11	PAF5	4 1/2	PBF2
36	PAD2	19	PAE3	10	PAF4	4	PBF1	
 <b>LEAD SCREW-P=6mm</b>								
C								
0.5	PSF1	1.75	PSE10	3.5	PSD10	6	PUD7	
0.75	PSF7	2	PSD1	4	PUD1	7	PUD10	
1	PSE1	2.25	PSD2	4.5	PUD2			
1.25	PSE4	2.5	PSD4	5	PUD4			
1.5	PSE7	3	PSD7	5.5	PUD5			

For Swing 16" , 18" (410mm, 460mm) Series while Imperial Leadscrew.

	LEAD SCREW – 4TPI							
	R							
	56	PAD10	32	PAD1	18	PAE2	9 1/2	PAF3
	54	PAD9	28	PAE10	16	PAE1	9	PAF2
	52	PAD8	27	PAE9	14	PAF10	8	PAF1
	48	PAD7	26	PAE8	13 1/2	PAF9	7	PBF10
	46	PAD6	24	PAE7	13	PAF8	6	PBF7
	44	PAD5	23	PAE6	12	PAF7	5 1/2	PBF5
	40	PAD4	22	PAE5	11 1/2	PAF6	5	PBF4
38	PAD3	20	PAE4	11	PAF5	4 1/2	PBF2	
36	PAD2	19	PAE3	10	PAF4	4	PBF1	
LEAD SCREW – 4TPI								
C								
0.5	PSF1	1.75	PSE10	3.5	PSD10	6	PUD7	
0.75	PSF7	2	PSD1	4	PUD1	7	PUD10	
1	PSE1	2.25	PSD2	4.5	PUD2			
1.25	PSE4	2.5	PSD4	5	PUD4			
1.5	PSE7	3	PSD7	5.5	PUD5			

## 6. LUBRICATION

### 6-1 Headstock Lubrication

Headstock lubrication is splash injection type. Oil grooves are equipped around the headstock to provide lubricant flowing from oil grooves to spindle, then finally reach the bottom of the headstock. To add oil, take off the oil plug on the top of the headstock cover, fill to the centerline of oil sight glass. Oil drain hole is located on the right bottom side of the headstock.

Before operating the lathe, be sure the headstock is filled with oil. If not, add Shell Tellus ③. Exchange oil after one month use for the first time. Thereafter every two months.

### 6-2 Gear Box & Apron Lubrication

1. Gear box is a reservoir oil bath type. To ensure the long service life of gear box and bedways, exchange the oil of gear box every six months.
2. Apron is also a reservoir oil bath type. Add the oil as soon as the oil is lower than the center line of the sight glass.

### 6-3 Lubrication Charts

No.	Location	Methods	Quantity	Oil time	Exchange time
1	Headstock	Loosen the oil input hole screw on the left top side of the headstock cover	L	Once per month	One month at the beginning, thereafter once two months.
2	Gear Box	Open the top cover and loosen the oil input hole screw	L	Once per month	Every six month
3	Apron	Loosen the oil input hole screw	L	Once per month	
4	Compound rest	Add oil with oil can	As required	Once per month	
5	Auto Feeding rod	Add oil with oil can	As required	Once per month	
6	Tailstock	Add oil with oil can	As required	Once per month	
7	Leadscrew	Add oil with oil can	As required	Once per month	
8	Bedway	Press the manual oil pump	As required	Once per month	

## 6-4 Lubrication Location

A: Oil input hole

B: Oil drain hole

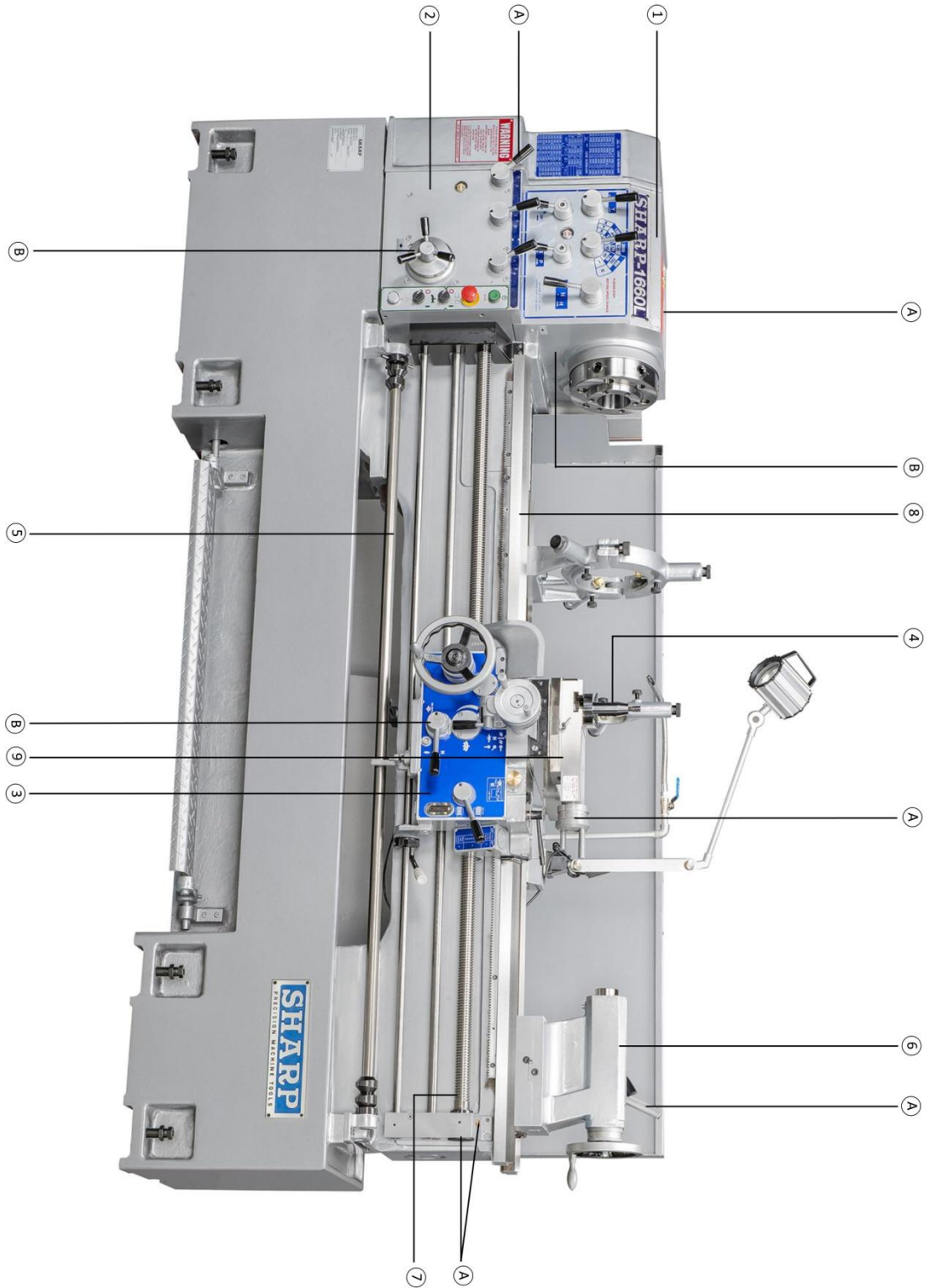

## 7. MAINTENANCE & ADJUSTMENT

Please refer to following items for machine problem solution and maintenance for obtaining the best function and the long service life of the lathe.

### 7-1 Headstock

1. To avoid the headstock cover oil leaking: Once the headstock cover is opened, use cloth to clean the connecting surface grease, then can close the cover and tighten the set screw.
2. To avoid the returning oil route being blocked: There are two reasons which cause the oil leaking from headstock front cover; one is over oiled; the other is that the returning oil route is blocked. It should take off the headstock cover. Then blow air to the small hole, which is on the top of the front bearing, by air gun several times. And rotate the spindle at the same time to clean up the blocked returning oil route.
3. Spindle bearing adjustment: The front and middle bearings of the spindle is precision taper roller type. It requires to adjust the bearings to have suitable preload for maintaining the high accuracy and the best rotating functions. After long use the locking nut G may be loose a little bit and result in uneven cutting surface. For adjustment, loosen the setscrew by hexagon wrench. Then tighten the locking nut G to obtain the suitable preload. Do not over-tighten as over-preload will make the bearings hot, damage the rotating surface of the bearings and lower down the bearing motion functions. After adjustment, be sure to tighten the locking screw completely.

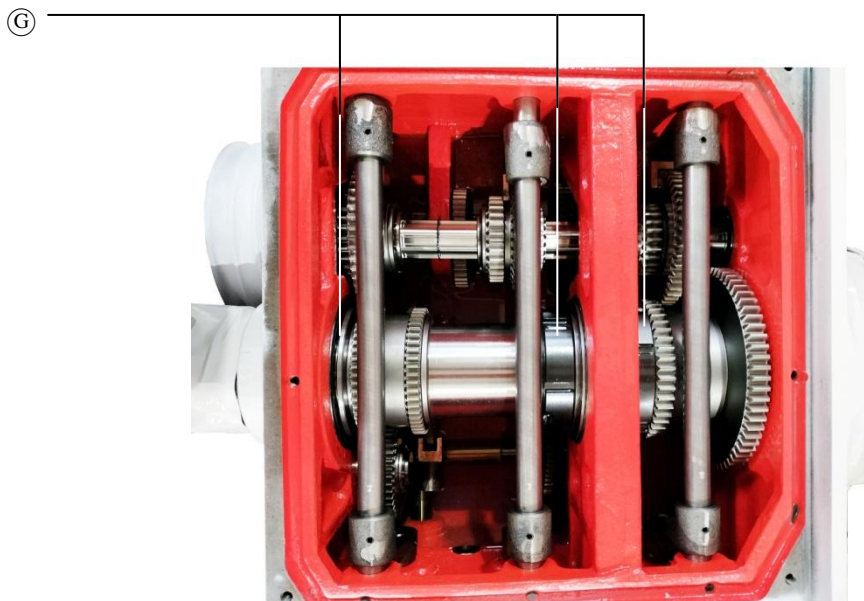



## 7-2 Apron & Saddle

1. Apron lubrication location: on the right top side of the saddle base. The oil inlet is plugged and marked "OIL" is the oil hole.
2. Apron drain hole located on the bottom cover of the apron as show on the right figure, the drain plug marked (A) (also see chart on the front bottom side of the apron).
3. Oil brand and oil exchange time: Use Shell Tellus No. 220 and exchange the oil half a year.
4. To adjust the half nut engaged lever: After long use, the lever may be loosened and needed to be adjusted. First, take off the thread dial indicator and find the 4 gib strip adjusting screws. Second, while pressing the lever, also adjust the 4 gib strip adjusting screws until they are properly tightened. Afterwards, replace the thread dial indicator.
5. To clear up and repair the manual pump being blocked or small oil flow: If no oil oozes out after pushing the manual pump several times, the pump is blocked. Take off the 4 setscrews of the pump body and loosen the plug lever to dismantle the set nut. Use air gun to clean up the inside of the blocked pump. If the oil flow is too small, it must be the O-ring worn out, replace another new and O-ring and assemble back the dismantled parts accordingly.
6. Adjustment for the longitudinal & cross auto feeding overload: The cone clutch on the center of the apron is an overload device. The safety overload weight limitation is 12 Kg. Overload weight can be adjusted by means of the Hexagon screw on the center of the apron; tighten clockwise, the overload will increase; tighten anticlockwise, the overload will then decrease. When auto-feeding, press the handwheel by hand, it should automatically slip out if the overload is over 12Kg. If not, adjust again.

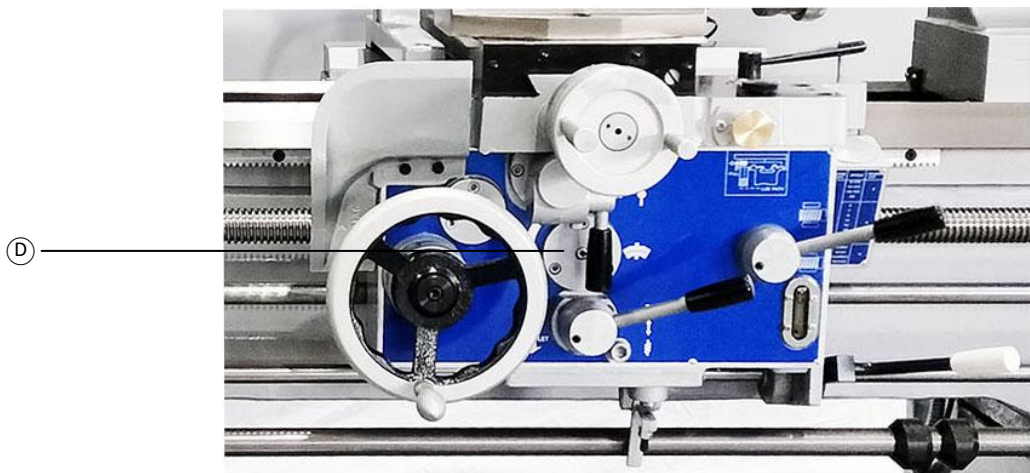
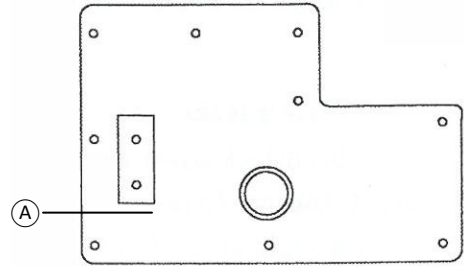



### 7-3 Gear Box

1. Lubrication location: Below the top cover of the apron, take off the top cover to find the oil plug marked “OIL”, the oil inlet hole.
2. Drain hole: On the left bottom side of the 10-step feed selection dial. The screw with hexagon nut is the oil drain hole as arrow (B) shown on figure 7-3.
3. Oil brand and oil exchange time: Use Shell Tellus No. 220 and exchange the oil half a year.



Fig.7-3

### 7-4 Tailstock Center Line Adjustment

First, unclamp the tailstock body clamping lever, and then loosen the 2 hexagon head screw on both right and left sides which lock the tailstock body and base together. Determine the direction and amount of the misalignment for adjustment by positioning a test bar between two dead centers. Slacken the rear ‘location screw’ (say one half turn). Then alternatively slacken one set-over screw and tighten the other until the required setting is achieved, (correct alignment). Carefully retighten the rear ‘location screw’ and the set over screw which was slackened before and recheck alignment. Retighten the two hexagon head screw carefully and re-clamp the tailstock (Fig. 7-4).

If still can not operate the handwheel easily after the tailstock quill is fixed, it is caused by the reason that the clamping block can not be loosened. To solve it, just push the tailstock body clamping lever forward one time for recovering.



Fig.7-4

### 7-5 Belt Tension Adjustment

After long use, the belt will stretch and require periodic tension adjustment.

1. Take off the cover on the left back side of the lathe.
2. Loosen adjusting nut ① and lower down the suitable height until the desired belt tension is achieved.
3. After adjustment, be sure to tighten the adjusting nut securely.



Fig.7-5

### 7-6 Brake Belt Adjustment

If the brake belt is worn out and cause the brake band tool loosen, it is time to adjust the nut ② of the brake band. Remove the side rear cover, loosen the nuts on the top firstly and tighten the nuts on the bottom to the appropriate height. Then tighten the nuts on the top to complete the adjustment. After adjustment, replace the side rear cover.

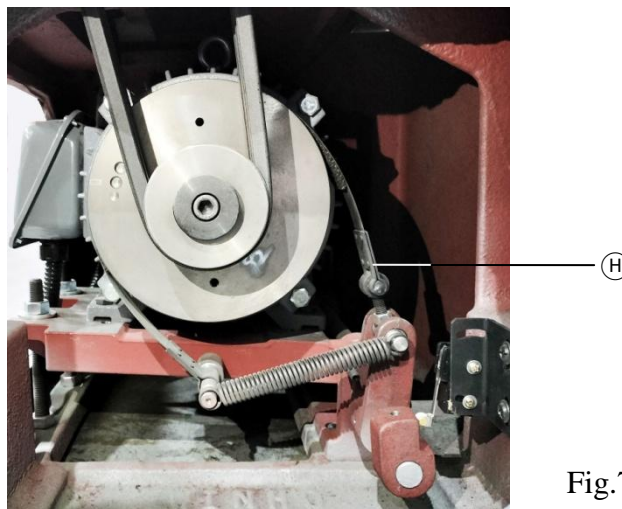

Fig.7-6

### 7-7 Brake & Micro Switch Adjustment

The foot brake is connected with the micro switch. It should have 0-1 mm end play between the brake arm and the touching, head of the micro switch. The correct brake action should cut off the electricity first, then brake avoid the brake belt being worn out. After stepping the foot brake, needs to re-operate the spindle operation control lever to make the spindle revolute again.

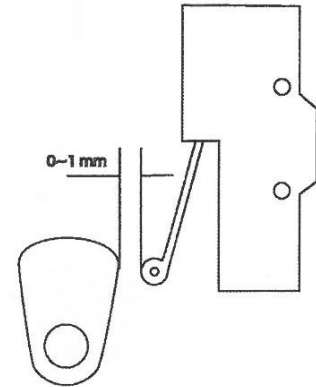

Fig. 7-7

### 7-8 Leadscrew Backlash Adjustment

If multiple cutting is happened while threading, it is caused by the leadscrew backlash. To adjust the leadscrew half nut properly, open the plastic cover of the leadscrew bracket and loosen nut ①. Then tighten the left side nut ② until there is no backlash. (For testing, press down the half nut by hand, turn the apron handwheel forward and reverse and grasp the connecting section of the gear box and leadscrew till no backlash happened.) Afterwards, replace the nut ① to the leadscrew bracket.



Fig. 7-8

### 7-9 Cutting Coolant Repair

If there is no coolant coming out after the pump switch is turned on, check the pump motor is working or not. If yes, check and see if the coolant in the tank is over the pump or not, If not, add the coolant, then turn on the switch. If there is still no coolant, the pump must be blocked. Take off the pump to clean up or repair.

## **8. Taper Attachment**

### **Installation Taper of Attachment:**

#### **STEP1:**

Install taper attachment on the carriage using screws NO.③① via hole “A”  
(Don't tighten too tight using screw M10x40L and flat washer.)

#### **STEP2:**

Disengaged screw NO.⑧

#### **STEP3:**

Adjust the position of NO.① and let are gage point is contacted with  
NO.206009.

#### **STEP4:**

Set a dial gage on the NO.⑱, and gage point is contacted the surface of bed.  
Moving NO.⑱, pointer has to be constant lift's not, adjusting the position of  
NO.①.

#### **STEP5:**

Disengaged screw NO.206010 then locked NO.206009 to NO.⑦

#### **STEP6:**

Replaced screw NO.⑧

#### **STEP7:**

Drill B hole. (Using  $\emptyset$  6m/m driller)

#### **STEP8:**

Set straight pin. ( $\emptyset$  6x45l)

#### **STEP9:**

Install universal connected-rod.

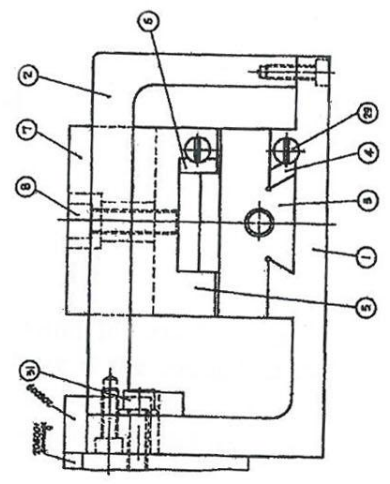
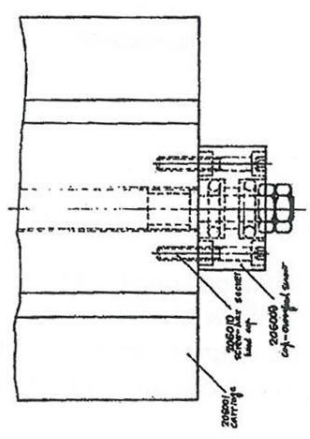
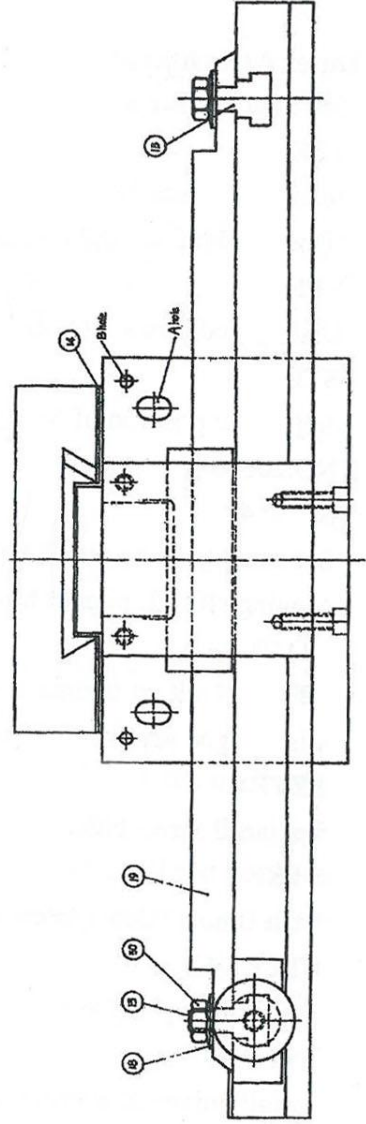
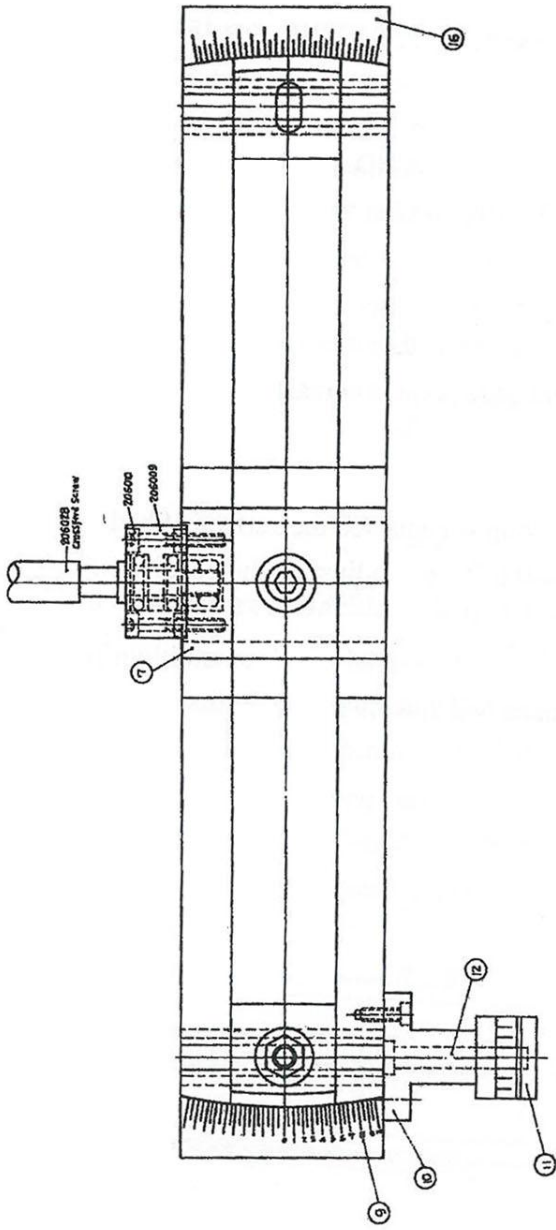

# TROUBLESHOOTING THE “C” MODEL LATHE

The objective is to locate and isolate the problem

## NOISE IN HEADSTOCK/GEARBOX:

Note: 85 % of noise normally comes from the output shaft pulley.

1. Run lathe with all controls in neutral to see if the problem is in **the spindle**.
  - a. If the problem is in the spindle and the finish is good, the source is most likely in the rear bearing (Part #65). However if the finish is poor the problem could be the front bearings are either loose or damaged.
  - b. If the problem is not in the spindle, continue by engaging one control at a time until the problem is found. **(Figure 1)**
  - c. If the problem is not in the headstock, and before you continue to the gear box, check the change gears (Parts #41, 78 & 89) located on the back of the headstock for proper backlash and alignment. **(Figure 2)** If these gears are found to be in good working order, perform the same sequence as above on the gearbox. (engage one control) at a time until the problem is located. **(Figure 3)**
  - d. Once you determine the problem is either in the gearbox or the headstock, that part of the machine must be opened up to inspect for possible worn or broken parts.
2. If the gearbox is in order and the feed or lead screws are not turning check the shear pins. (There are two shear pins on each shaft). **(Figure 4)**

Notes:

---

---

---

---

---





Figure 1

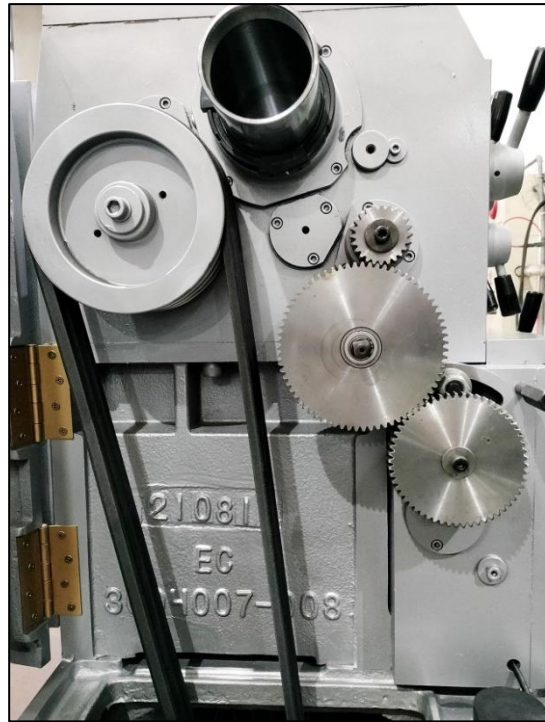

Figure 2



Figure 3

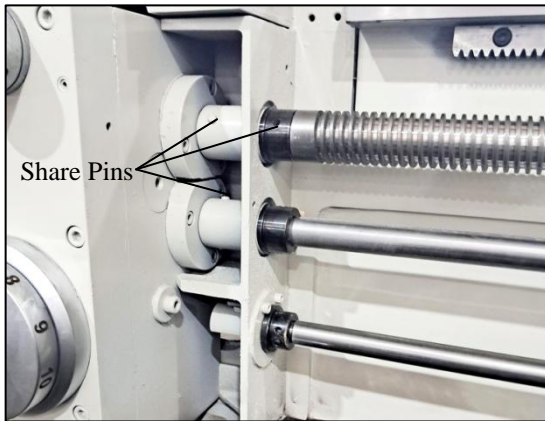

Figure 4

**THREADING PROBLEMS:**

Should there be a problem cutting **standard threads:**

- a. Check the chasing dial to see if it is loose from shaft.
- b. Check gear at bottom of shaft for tightness & proper fit against the lead screw.
- c. Check the half nut for proper fit.

**Note:** All Sharp Lathes are made to cut ASE (Inch) threads. To cut metric threads, make sure the half nuts are engaged at all times, because it is not a metric based machine, and therefore will not repeat according to the threading dials.

Notes:

---

---

---

---

---



**CHATTER/VIBRATION PROBLEMS:**

1. Spindle has excessive run out. **(Figure 5)**
2. Loose Compound, cross feed or saddle. **(Figure 6)**
3. Loose motor mount or motor not seated properly on base. **(Figure 7)**
4. Backlash on drive pulley shaft and key. **(Figure 2)**
5. New rack and old gear. (If machine has been crashed) **(Figure 8)**
6. Irregular power supply. (Not getting 3-phase)
7. Leveling bolts loose or lathe not properly leveled.
8. Defective live center. (On a long work piece chatter in the center & not on ends).

**COOLANT PUMP NOT WORKING OR PRESSURE TOO LOW.**

- a. Check coolant level.
- b. Check pump shaft for rotation. (Proper rotation is clockwise).
- c. Check for clogged line. (Both suction and discharge).

Notes:

---

---

---

---

---

# ADJUSTMENTS AND REPAIRS:

## ADJUSTING LEAD SCREW BACKLASH

- a. Remove plastic cover on the lead screw bracket.
- b. Loosen lock nut "A" under cover.
- c. Tighten left side nut "B" until backlash has been removed.
- d. Re-tighten lock nut "A" and replace plastic cover. (**Figure 9**)

## ADJUSTING SPINDLE BEARINGS

The front and middle spindle bearings are **precision taper roller bearings**. To adjust:

- a. Loosen set screw (Part #60) on locking NUT (Part #62).
- b. Tighten locking nut (Part #62) to obtain proper preload. (Check by spinning chuck by hand. Chuck should rotate freely for at least 2 revolutions).
- c. Re-tighten set screw (Part #60) on lock nut. (**Figure 10**)

Notes:

---

---

---

---

---

### **ADJUSTING THE FEED OVERLOAD**

This machine is equipped with a safety overload which can be adjusted by the set screw (Part # 73) located in the center of cover (Part # 75) which is located in the center of the apron. (To increase tension turn clockwise, to reduce tension turn counterclockwise). **(Figure 13)**

### **ADJUSTING HALF NUTS**

1. Remove chasing dial assembly
  2. Loosen 3 screws
  3. Adjust half nuts and re-tighten the 3 screws
  4. Test movement before reassembling.
- (Figure 17)**

Notes:

---

---

---

---

---

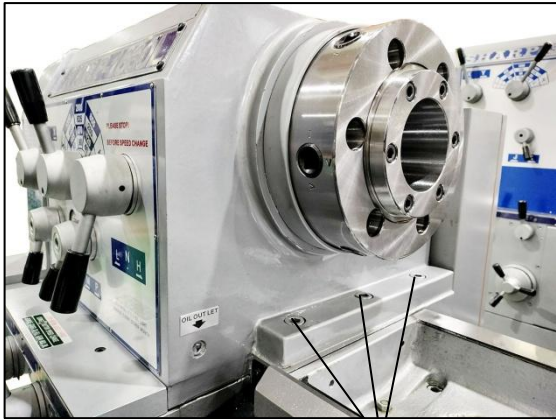

Figure 5  
Loosen bolts a bit when aligning Head.



Figure 6



Figure 7

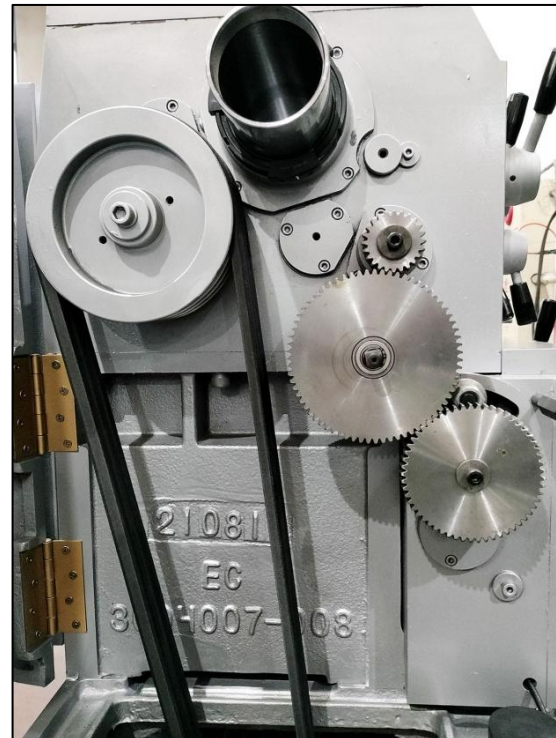

Figure 2

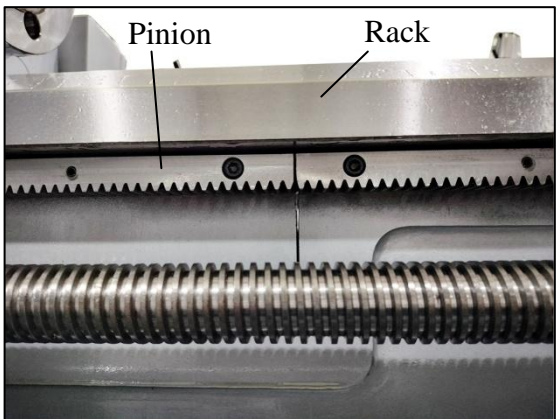

Figure 8

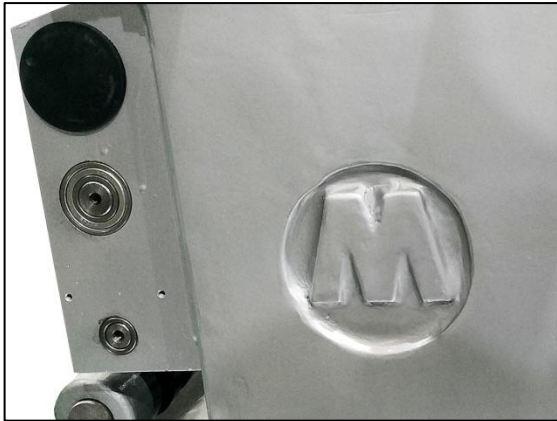

Figure 9

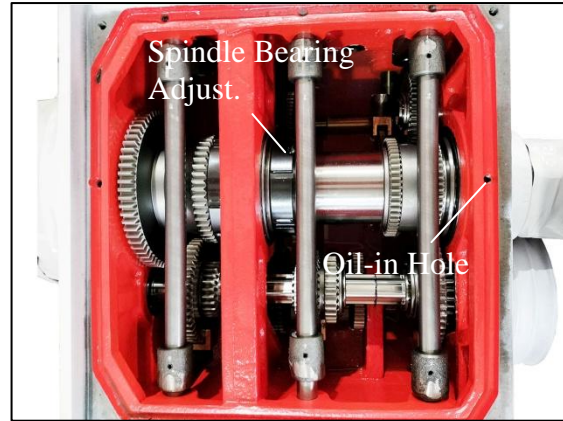

Figure 10

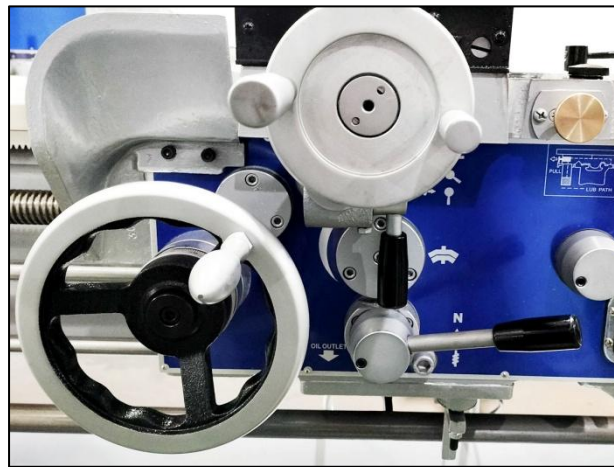

Figure 13

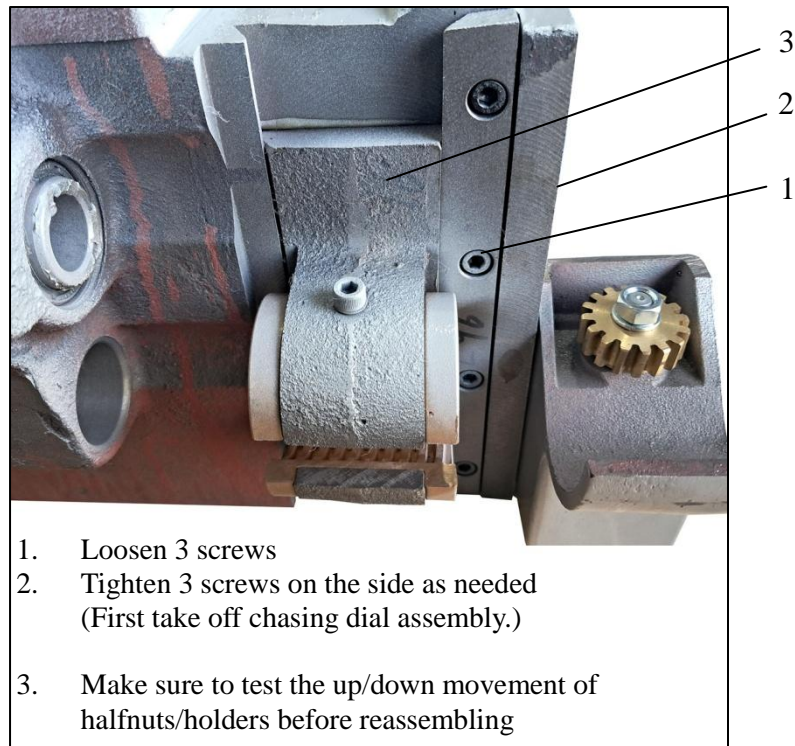

Figure 17

## **OIL LEAKS**

**Headstock top cover leak:** Remove cover, clean all surfaces with a clean rag, apply a small coat of *grease* on the gasket surface and reinstall the cover.

**Oil leak around the spindle** is most likely caused by the oil level being too high or oil return hole over the spindle being blocked or restricted. Most of the time this oil inlet hole can be cleaned out by simply blowing air through the passage. **(Figure 10)**

\*\*\**Note:* Make sure to use 10W Oil only! Higher viscosity will result in leak!

### **Oil leak at the rear of spindle:**

1. Mark lock nut and spindle. **(Figure 11)**
2. Mark balance weights on lock nut **(Figure 11)**
3. Remove lock nut. (First remove set screw )
4. Remove cover
5. Clear oil return hole using air pressure. **(Figure 12)**

**Note:** Be sure cover is not obstructing return.

## **ALIGNING THE HEAD**

A taper will most likely be created by the head being out of alignment. To align head:

1. Loosen bolts on base of head slightly. (3 in front and 3 in back) **(Figure 5)**
2. Make appropriate adjustment to correct problem.
  - a. "C" Model adjusting screws are in front of lathe.
  - b. "S" and "F" Models adjusting screws are in the back of the lathe.

Notes:

---

---

---

---

---

## **APRON REMOVAL**

1. Remove dowel pins from lead screw and feed shaft (**Figure 4**)
2. Remove chasing dial assembly (**Figure 15**)
3. Remove rotation lever assembly (**Figure 15**)
4. Remove lead screw bracket and slide lead screw & lead shafts out of apron (**Figure 16**)
5. Removing 4 bolts will allow the apron to be removed. (Caution should be taken when removing, due to its weight).

Notes:

---

---

---

---

---



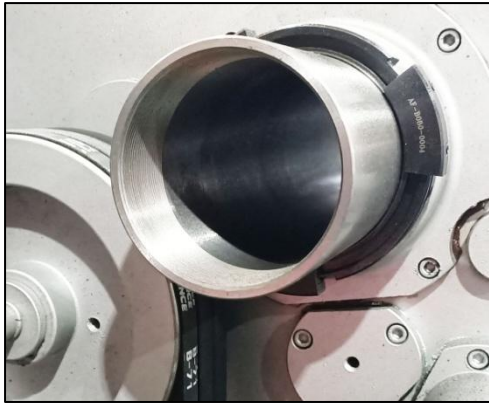

Figure 11



Figure 12

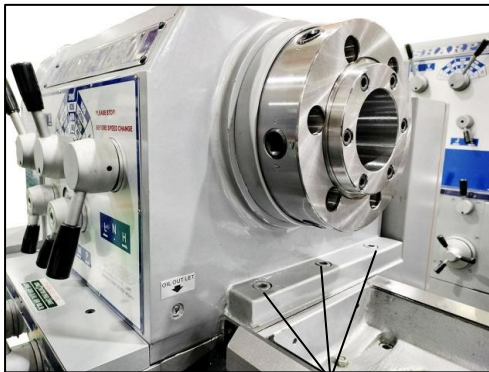

Figure 5 Loosen bolts a bit when aligning Head.

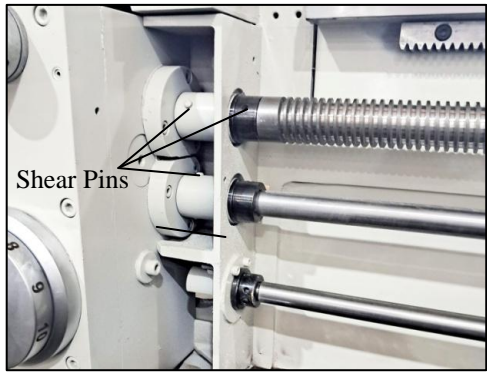

Figure 4

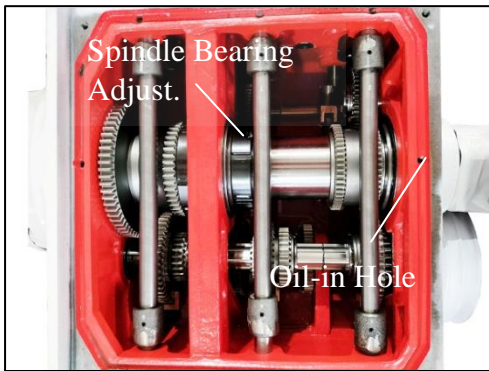

Figure 10



Figure 16

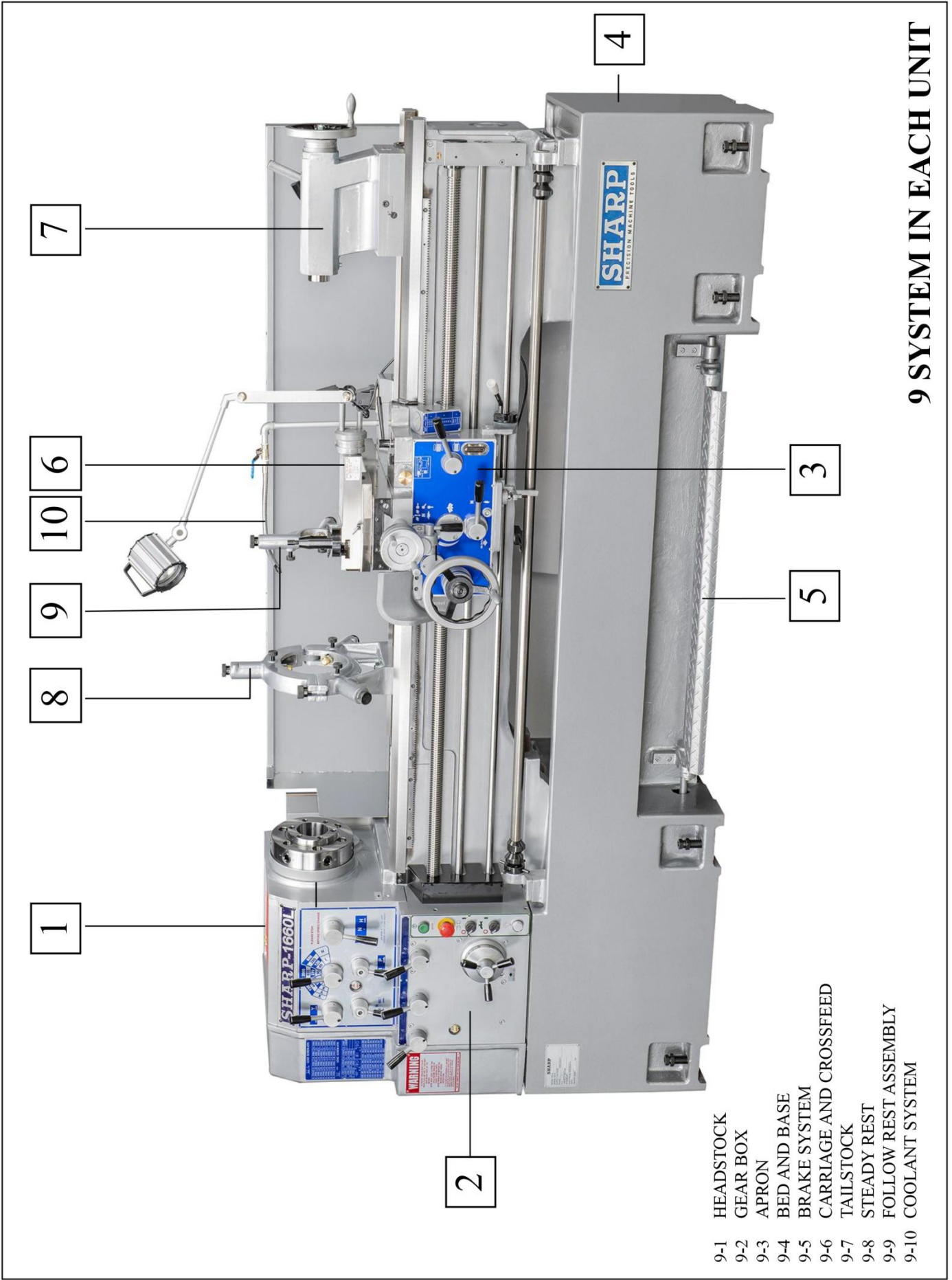

Figure 15



## CONTENTS

9	SYSTEM IN EACH UNIT.....	1
9.1	HEADSTOCK.....	2
9.2	GEAR BOX.....	11
9.3	APRON.....	16
9.4	BED AND BASE .....	21
9.5	BRAKE SYSTEM.....	24
9.6	CARRIAGE AND CROSSFEED.....	26
9.7	TAILSTOCK .....	31
9.8	STEADY .....	33
9.9	FOLLOW REST ASSEMBLY .....	35
9.10	COLLANT SYSTEM ASSEMBLY .....	37



- 9-1 HEADSTOCK
- 9-2 GEAR BOX
- 9-3 APRON
- 9-4 BED AND BASE
- 9-5 BRAKE SYSTEM
- 9-6 CARRIAGE AND CROSSFEED
- 9-7 TAILSTOCK
- 9-8 STEADY REST
- 9-9 FOLLOW REST ASSEMBLY
- 9-10 COOLANT SYSTEM

**9 SYSTEM IN EACH UNIT**

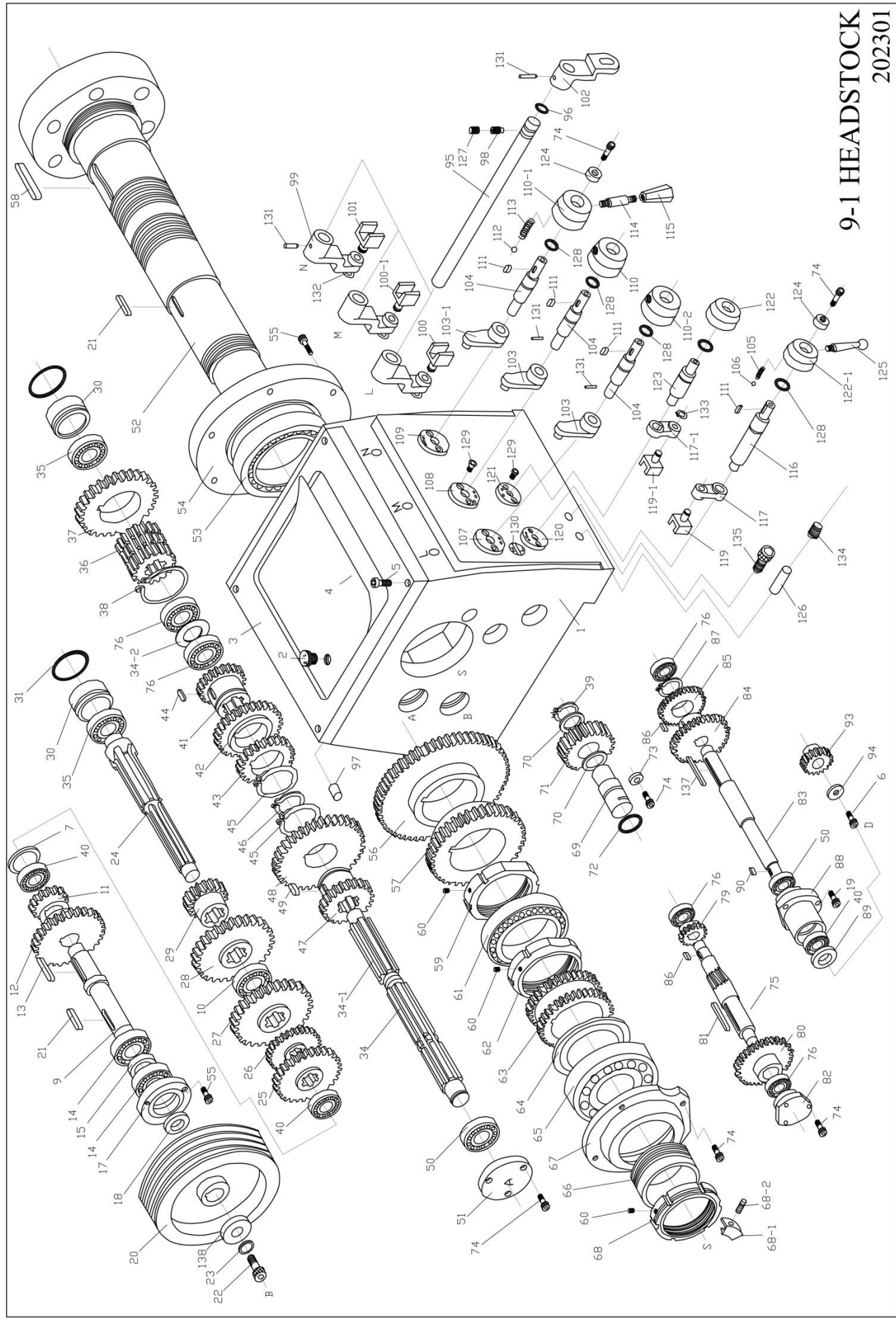

9-1 HEADSTOCK  
202301

## HEADSTOCK ASSMBLY (Spindle Bore : 58mm or 2")

Item No.	Part Name	Amt. Used	Model: 17"(430) Part No.	Model: 19"(480) Part No.	Model: 21"(530) Part No.
1	Head stock	1	3001001-172	3001001-192	3001001-212
2	Oil plug	1	3001002	3001002	3001002
3	Head stock cover	1	3001003	3001003	3001003
4	Blanket	1	3001004	3001004	3001004
5	Hexagon socket screw, M8xP1.25x35L	4	91110835	91110835	91110835
6	Hexagon socket screw, M8xP1.25x25L	1	9110825	9110825	9110825
7	Snap ring , R48	1	9171R048	9171R048	9171R048
9	Input-shaft	1	3001009	3001009	3001009
10	Ball bearing , 6206	1	91301021	91301021	91301021
11	Gear-i	1	3001011	3001011	3001011
12	Gear-g	1	3001012	3001012	3001012
13	Square key , 8x7x45L	1			
14	Ball bearing , 6206	2	91301021	91301021	91301021
15	Collar	1	3001015	3001015	3001015
17	Housing	1	3001017	3001017	3001017
18	Oil-seal , TC30x50x8	1	91523001	91523001	91523001
19	Hexagon socket screw, M6xP1.0x20L	3	91110620	91110620	91110620
20	Pulley	1	3001020	3001020	3001020
21	Square key , 8x7x45L	3			
22	Hexagon socket screw, M12xP1.75x30L	1	91111230	91111230	91111230
23	Washer	1			
24	Shaft-B	1	3001024	3001024	3001024
25	Gear-d	1	3001025	3001025	3001025
26	Gear-b	1	3001026	3001026	3001026
27	Gear-f	1	3001027	3001027	3001027
28	Gear-k	1	3001028	3001028	3001028
29	Gear-o	1	3001029	3001029	3001029
30	Plug-cover	2	3001030	3001030	3001030
31	O-ring , P50x3.5	2	9151P050	9151P050	9151P050
34	Shaft-A	1	3001034	3001034	3001034
34-1	Shaft-L	1	3001034-001	3001034-001	3001034-001
35	Ball bearing , 6305	1	91301029	91301029	91301029
36	Gear-l	1	3001036	3001036	3001036
37	Gear-m	1	3001037	3001037	3001037
38	Snap ring , S65	2	9171S065	9171S065	9171S065
39	Snap ring , S30	1	9171S030	9171S030	9171S030
40	Ball bearing , 6005	3	91301010	91301010	91301010
41	Gear-e	1	3001041	3001041	3001041
42	Gear-a	1	3001042	3001042	3001042
43	Gear-c	1	3001043	3001043	3001043
44	Square key , 8x7x85L	1			
45	Snap ring , S48	2	9171S048	9171S048	9171S048

## HEADSTOCK ASSMBLY (Spindle Bore : 58mm or 2")

Item No.	Part Name	Amt. Used	Model: 19"(480) Part No.	Model: 19"(480) Part No.	Model: 19"(480) Part No.
46	Snap ring , S34	1	9171S034	9171S034	9171S034
47	Gear-h	1	3001047	3001047	3001047
48	Gear-j	1	3001048	3001048	3001048
49	Square key , 8x7x85L	1			
50	Ball bearing , 6205	1	91301020	91301020	91301020
51	Cover	1	3001051	3001051	3001051
52	Spindle (A1-6)	1	3001052-A01	3001052-A01	3001052-A01
	(D1-6)	1	3001052-D01	3001052-D01	3001052-D01
53	Taper roller bearing, 32018		91302014	91302014	91302014
54	Cover (A1-6)	1	3001054-A01	3001054-A01	3001054-A01
	(D1-6)	1	3001054-D01	3001054-D01	3001054-D01
55	Hexagon socket screw, M6xP1.0x35L	6	91110635	91110635	91110635
56	Gear-p	1	3001056	3001056	3001056
57	Gear-n	1	3001057	3001057	3001057
58	Square key , 8x7x85L	1	91620806	91620806	91620806
59	Lock-nut	1	3001059	3001059	3001059
60	Sett screw, M8xP1.25x8L	5	91120808	91120808	91120808
61	Taper roller bearing, 32017	1	91302013	91302013	91302013
62	Lock-nut	1	3001062	3001062	3001062
63	Gear	1	3001063	3001063	3001063
64	Collar	1	3001064	3001064	3001064
65	Ball bearing , 6215	1	91301024	91301024	91301024
66	Oil return collar	1	3001066	3001066	3001066
67	Cover	1	3001067	3001067	3001067
68	Lock-nut	1	3001068	3001068	3001068
68-1	Balance piece	3	3001068-001	3001068-001	3001068-001
68-2	Set screw, M5x8	6	3001068-002	3001068-002	3001068-002
69	Idle gear shaft	1	3001069	3001069	3001069
70	Spacer	2	3001070	3001070	3001070
71	Idle gear	1	3001071	3001071	3001071
72	O-ring , P29	1	9151P029	9151P029	9151P029
73	Washer	1	3001073	3001073	3001073
74	Hexagon socket screw, M6xP1.0x12L	13	91110612	91110612	91110612
75	Gear shaft-C	1	3001075	3001075	3001075
76	Ball bearing , 6204	5	91301018	91301018	91301018
79	Gear	1	3001079	3001079	3001079
80	Gear	1	3001080	3001080	3001080
81	Square key , 6x6x65L	1			
82	Cover	1	30010802	30010802	30010802
83	Shaft-D	1	30010803	30010803	30010803
84	Gear	1	30010804	30010804	30010804
85	Gear	1	30010805	30010805	30010805



## HEADSTOCK ASSMBLY (Spindle Bore : 58mm or 2")

Item No.	Part Name	Amt. Used	Model: 17"(430) Part No.	Model: 19"(480) Part No.	Model: 21"(530) Part No.
86	Square key , 6x6x18L	2	91610604	91610604	91610604
87	Snap ring , S40	1	9171S040	9171S040	9171S040
88	Housing	1	3001088	3001088	3001088
89	Oil-seal , TC25x47x8L	1	91522501	91522501	91522501
90	Square key , 6x6x12L	1	91610601	91610601	91610601
91	Collar	1	3001091	3001091	3001091
92	Taper pin ,0#25L	1	92010025	92010025	92010025
93	Gear (24T in)	1	3001093	3001093	3001093
	Gear (41T mm)	1	3001093-001	3001093-001	3001093-001
94	Washer	1			
95	Shifting shaft	3	3001095	3001095	3001095
96	O-ring , P16	6	9151P016	9151P016	9151P016
97	Plug	3	3001097	3001097	3001097
98	Set screw	3	3001098	3001098	3001098
99	Shifting lever	3	3001099	3001099	3001099
100	Shifting fork	1	3001100	3001100	3001100
100-1	Shifting fork	1	3001100-001	3001100-001	3001100-001
101	Shifting fork	1	3001101	3001101	3001101
102	Shifting lever	3	3001102	3001102	3001102
103	Shifting lever	2	3001103	3001103	3001103
103-1	Shifting lever	1	3001103-001	3001103-001	3001103-001
104	Shaft	3	3001104	3001104	3001104
105	Spring , D6xd0.8x25L	2			
106	Ball steel , Ø 1/4"	2	91820104	91820104	91820104
107	Detent plate	1	3001107	3001107	3001107
108	Detent plate	1	3001108	3001108	3001108
109	Detent plate	1	3001109	3001109	3001109
110	Hub	1	3001110	3001110	3001110
110-1	Hub	1	3001110-001	3001110-001	3001110-001
110-2	Hub	1	3001110-002	3001110-002	3001110-002
111	Square key , 5x5x15L	2	91610501	91610501	91610501
112	Ball steel , Ø5/16"	3	91820516	91820516	91820516
113	Spring , D8xd0.8x25L	3	3001113	3001113	3001113
114	Lever	3	3001114	3001114	3001114
115	Knob	3	3001115	3001115	3001115
116	Shaft	1	3001116	3001116	3001116
117	Shifting lever	1	3001117	3001117	3001117
117-1	Shifting lever	1	3001117-001	3001117-001	3001117-001
118	Shifting lever	1	3001118	3001118	3001118
119	Shifting fork	1	3001119	3001119	3001119
119-1	Shifting fork	1	3001119	3001119	3001119
120	Detent plate	1	3001120	3001120	3001120
121	Detent plate	1	3001121	3001121	3001121
122	Knob	1	3001122	3001122	3001122
122-1	Knob	1	3001122-001	3001122-001	3001122-001

## HEADSTOCK ASSMBLY (Spindle Bore : 58mm or 2")

Item No.	Part Name	Amt. Used	Model: 17"(430) Part No.	Model: 19"(480) Part No.	Model: 21"(530) Part No.
123	Shaft	1	3001123	3001123	3001123
124	Washer	5	3001124	3001124	3001124
125	Lever	2	3001125	3001125	3001125
126	Pin	2	3001126	3001126	3001126
127	Set screw, M8xP1.25x10L	3	91120810	91120810	91120810
128	O-ring , P18xP1.0x14L	5	9151P018	9151P018	9151P018
129	Screw , M6xP1.0x14L	10	91160614	91160614	91160614
130	Lenz-oil , Ø 29	1	92552001	92552001	92552001
131	Spring pin , Ø 5x32L	9	92030532	92030532	92030532
	Spring pin , Ø 5x26L	2	92030526	92030526	92030526
132	Snap ring , S12	3	9171S012	9171S012	9171S012
133	Snap ring , S10	2	9171S010	9171S010	9171S010
134	Set screw, M8xP1.25x10L	2	91121020	91121020	91121020
135	Hexagon socket screw, M10xP1.5x95L	2	91111095	91111095	91111095
136	Hexagon socket screw, M6xP1.0x40L	4	91110640	91110640	91110640
137	Square key , 6x6x70L	1	91610608	91610608	91610608
138	Spring washer , 12L	1			

## HEADSTOCK ASSMBLY (Spindle Bore : 80mm or 3")

Item No.	Part Name	Amt. Used	Model: 17"(430) Part No.	Model: 19"(480) Part No.	Model: 21"(530) Part No.
1	Head stock	1	3001001-173	3001001-193	3001001-213
2	Oil plug	1	3001002	3001002	3001002
3	Head stock cover	1	3001003	3001003	3001003
4	Blanket	1	3001004	3001004	3001004
5	Hexagon socket screw, M8xP1.25x35L	4	91110835	91110835	91110835
6	Hexagon socket screw, M8xP1.25x25L	1	9110825	9110825	9110825
7	Snap ring , R48	1	9171R048	9171R048	9171R048
9	Input-shaft	1	3001009	3001009	3001009
10	Ball bearing , 6206	1	91301021	91301021	91301021
11	Gear-i	1	3001011-001	3001011-001	3001011-001
12	Gear-g	1	3001012	3001012	3001012
13	Square key , 8x7x45L	1			
14	Ball bearing , 6206	2	91301021	91301021	91301021
15	Collar	1	3001015	3001015	3001015
17	Housing	1	3001017	3001017	3001017
18	Oil-seal , TC30x50x8	1	91523001	91523001	91523001
19	Hexagon socket screw, M6xP1.0x20L	3	91110620	91110620	91110620
20	Pulley	1	3001020	3001020	3001020
21	Square key , 8x7x45L	3			
22	Hexagon socket screw, M12xP1.75x30L	1	91111230	91111230	91111230
23	Washer	1			
24	Shaft-B	1	3001024	3001024	3001024
25	Gear-d	1	3001025	3001025	3001025
26	Gear-b	1	3001026	3001026	3001026
27	Gear-f	1	3001027	3001027	3001027
28	Gear-k	1	3001028	3001028	3001028
29	Gear-o	1	3001029-001	3001029-001	3001029-001
30	Plug-cover	2	3001030	3001030	3001030
31	O-ring , P50x3.5	2	9151P050	9151P050	9151P050
34	Shaft-A	1	3001034	3001034	3001034
34-1	Shaft-L	1	3001034-001	3001034-001	3001034-001
35	Ball bearing , 6305	1	91301029	91301029	91301029
36	Gear-l	1	3001036	3001036	3001036
37	Gear-M	1	3001037-001	3001037-001	3001037-001
38	Snap ring , S65	2	9171S065	9171S065	9171S065
39	Snap ring , S30	1	9171S030	9171S030	9171S030
40	Ball bearing , 6005	3	91301010	91301010	91301010
41	Gear-E	1	3001041	3001041	3001041
42	Gear-A	1	3001042	3001042	3001042
43	Gear-C	1	3001043	3001043	3001043
44	Square key , 8x7x85L	1			
45	Snap ring , S48	2	9171S048	9171S048	9171S048

## HEADSTOCK ASSMBLY (Spindle Bore : 80mm or 3")

Item No.	Part Name		Amt. Used	Model: 19"(480) Part No.	Model: 19"(480) Part No.	Model: 19"(480) Part No.
46	Snap ring , S34		1	9171S034	9171S034	9171S034
47	Gear-h		1	3001047	3001047	3001047
48	Gear-j		1	3001048-001	3001048-001	3001048-001
49	Square key , 8x7x85L		1			
50	Ball bearing , 6205		1	91301020	91301020	91301020
51	Cover		1	3001051	3001051	3001051
52	Spindle	(A1-8)	1	3001052-A03	3001052-A03	3001052-A03
		(D1-8)	1	3001052-D03	3001052-D03	3001052-D03
53	Taper roller bearing, 32922			91302028	91302028	91302028
54	Cover		1	3001054-003	3001054-003	3001054-003
55	Hexagon socket screw, M6xP1.0x35L		6	91110635	91110635	91110635
56	Gear-p		1	3001056-001	3001056-001	3001056-001
57	Gear-n		1	3001057-001	3001057-001	3001057-001
58	Square key , 8x7x85L		1	91620806	91620806	91620806
59	Lock-nut		1	3001059	3001059	3001059
60	Sett screw, M8xP1.25x8L		5	91120808	91120808	91120808
61	Taper roller bearing, 32920		1	91302029	91302029	91302029
62	Lock-nut		1	9124F100	9124F100	9124F100
63	Gear		1	3001063-001	3001063-001	3001063-001
64	Collar		1	3001064-001	3001064-001	3001064-001
65	Ball bearing , 6018		1	9130148	9130148	9130148
66	Oil return collar		1	3001066-001	3001066-001	3001066-001
67	Cover		1	3001067-001	3001067-001	3001067-001
68	Lock-nut		1	3001068	3001068	3001068
68-1	Balance piece		3	3001068-003	3001068-003	3001068-003
68-2	Set screw, M5x8		6	3001068-002	3001068-002	3001068-002
69	Idle gear shaft		1	3001069	3001069	3001069
70	Spacer		2	3001070	3001070	3001070
71	Idle gear		1	3001071	3001071	3001071
72	O-ring , P29		1	9151P029	9151P029	9151P029
73	Washer		1	3001073	3001073	3001073
74	Hexagon socket screw, M6xP1.0x12L		13	91110612	91110612	91110612
75	Gear shaft-C		1	3001075	3001075	3001075
76	Ball bearing , 6204		5	91301018	91301018	91301018
79	Gear		1	3001079	3001079	3001079
80	Gear		1	3001080-001	3001080-001	3001080-001
81	Square key , 6x6x65L		1			
82	Cover		1	30010802	30010802	30010802
83	Shaft-D		1	30010803-001	30010803-001	30010803-001
84	Gear		1	30010804	30010804	30010804
85	Gear		1	30010805	30010805	30010805

## HEADSTOCK ASSMBLY (Spindle Bore : 80mm or 3")

Item No.	Part Name	Amt. Used	Model: 17"(430) Part No.	Model: 19"(480) Part No.	Model: 21"(530) Part No.
86	Square key , 6x6x18L	2	91610604	91610604	91610604
87	Snap ring , S40	1	9171S040	9171S040	9171S040
88	Housing	1	3001088	3001088	3001088
89	Oil-seal , TC25x47x8L	1	91522501	91522501	91522501
90	Square key , 6x6x12L	1	91610601	91610601	91610601
91	Collar	1	3001091	3001091	3001091
92	Taper pin ,0#25L	1	92010025	92010025	92010025
93	Gear (24T in)	1	3001093	3001093	3001093
94	Washer	1			
95	Shifting shaft	3	3001095-001	3001095-001	3001095-001
96	O-ring , P16	6	9151P016	9151P016	9151P016
97	Plug	3	3001097	3001097	3001097
98	Set screw	3	3001098	3001098	3001098
99	Shifting lever	3	3001099	3001099	3001099
100	Shifting fork	1	3001100	3001100	3001100
100-1	Shifting fork	1	3001100-001	3001100-001	3001100-001
101	Shifting fork	1	3001101	3001101	3001101
102	Shifting lever	3	3001102	3001102	3001102
103	Shifting lever	2	3001103	3001103	3001103
103-1	Shifting lever	1	3001103-001	3001103-001	3001103-001
104	Shaft	3	3001104	3001104	3001104
105	Spring , D6xd0.8x25L	2			
106	Ball steel , Ø 1/4"	2	91820104	91820104	91820104
107	Detent plate	1	3001107	3001107	3001107
108	Detent plate	1	3001108	3001108	3001108
109	Detent plate	1	3001109	3001109	3001109
110	Hub	1	3001110	3001110	3001110
110-1	Hub	1	3001110-001	3001110-001	3001110-001
110-2	Hub	1	3001110-002	3001110-002	3001110-002
111	Square key , 5x5x15L	2	91610501	91610501	91610501
112	Ball steel , Ø5/16"	3	91820516	91820516	91820516
113	Spring , D8xd0.8x25L	3	3001113	3001113	3001113
114	Lever	3	3001114	3001114	3001114
115	Knob	3	3001115	3001115	3001115
116	Shaft	1	3001116	3001116	3001116
117	Shifting lever	1	3001117	3001117	3001117
117-1	Shifting lever	1	3001117-001	3001117-001	3001117-001
118	Shifting lever	1	3001118	3001118	3001118
119	Shifting fork	1	3001119	3001119	3001119
119-1	Shifting fork	1	3001119	3001119	3001119
120	Detent plate	1	3001120	3001120	3001120
121	Detent plate	1	3001121	3001121	3001121
122	Knob	1	3001122	3001122	3001122
122-1	Knob	1	3001122-001	3001122-001	3001122-001

### HEADSTOCK ASSMBLY (Spindle Bore : 80mm or 3")

Item No.	Part Name	Amt. Used	Model: 17"(430) Part No.	Model: 19"(480) Part No.	Model: 21"(530) Part No.
123	Shaft	1	3001123	3001123	3001123
124	Washer	5	3001124	3001124	3001124
125	Lever	2	3001125	3001125	3001125
126	Pin	2	3001126	3001126	3001126
127	Set screw, M8xP1.25x10L	3	91120810	91120810	91120810
128	O-ring , P18xP1.0x14L	5	9151P018	9151P018	9151P018
129	Screw , M6xP1.0x14L	10	91160614	91160614	91160614
130	Lenz-oil , Ø 29	1	92552001	92552001	92552001
131	Spring pin , Ø 5x32L	9	92030532	92030532	92030532
	Spring pin , Ø 5x26L	2	92030526	92030526	92030526
132	Snap ring , S12	3	9171S012	9171S012	9171S012
133	Snap ring , S10	2	9171S010	9171S010	9171S010
134	Set screw, M8xP1.25x10L	2	91121020	91121020	91121020
135	Hexagon socket screw, M10xP1.5x95L	2	91111095	91111095	91111095
136	Hexagon socket screw, M6xP1.0x40L	4	91110640	91110640	91110640
137	Square key , 6x6x70L	1	91610608	91610608	91610608
138	Spring washer	1			

# 9-2 GEAR BOX

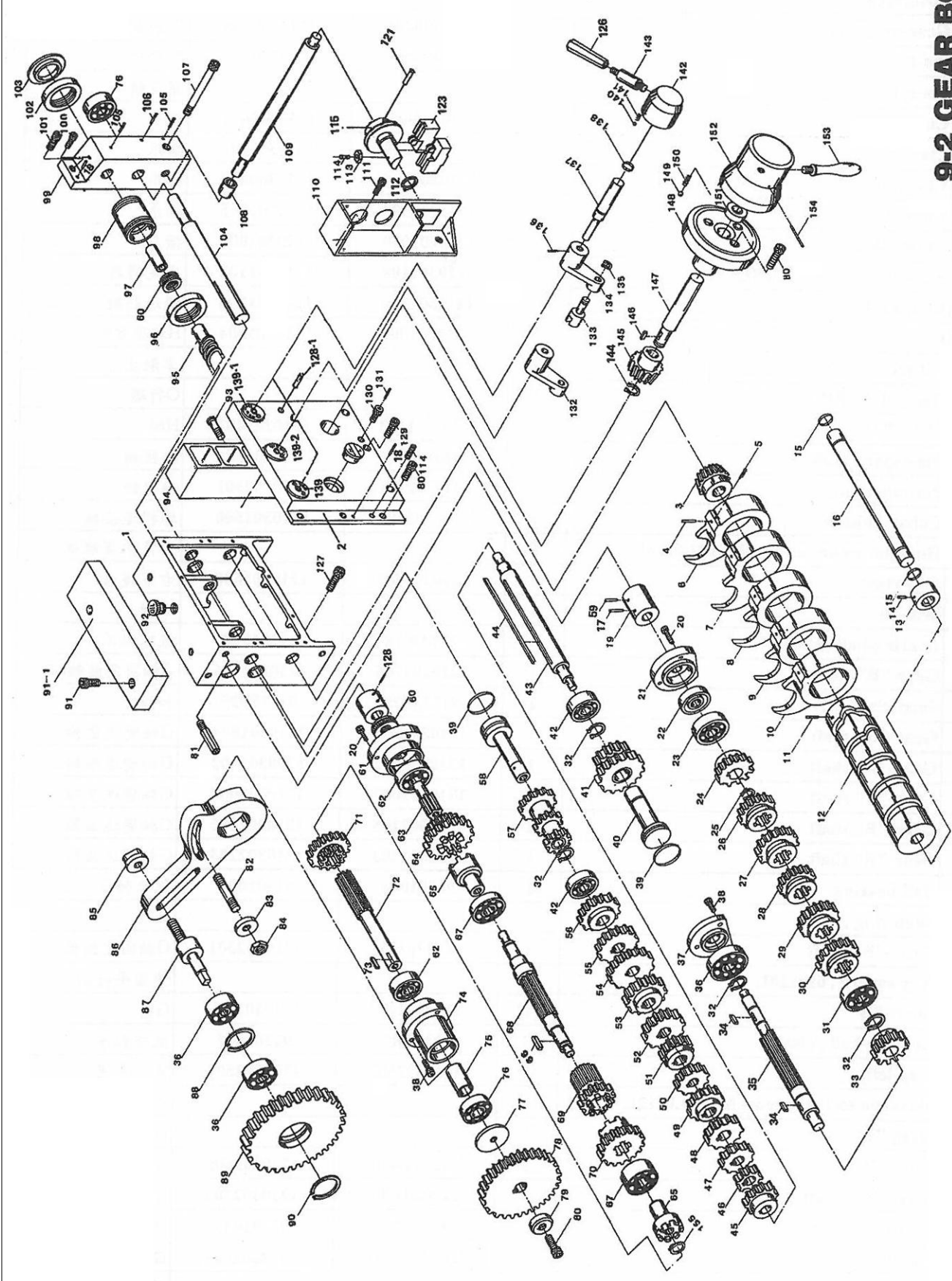



## GEAR BOX ASSEMBLY

Item No.	Part Name	Amt. Used	Type: 16 Part No.	Type: 18 Part No.
1	Gear box	1	1210300307	1210300307
2	Cover-gear box	1	1210300101	1210300101
3	Gear-driven bevel	1	1210300405	1210300405
4	Pin-fixed	5	1210300503	1210300503
5	Pin-split	5		
6	Claw-shifter	1	1210300601	1210300601
7	Claw-shifter	1	1210300709	1210300709
8	Claw-shifter	1	1210300807	1210300807
9	Claw-shifter	1	1210300905	1210300905
10	Claw-shifter	1	1210301000	1210301000
11	Set screw , M8xP1.25x8L	1	1210301108	1210301108
12	Cam-shifter	1	1210301206	1210301206
13	Collar	1	1210301304	1210301304
14	Set screw , M8x12	2		
15	Ring-"O" , P18	2		
16	Shaft-"A"	1	1210301402	1210301402
17	Pin-taper , 4x38	3	92010438	92010438
18	Pin-taper , 6x38	2	1210702301	1210702301
19	Collar-linkage	1	1210301500	1210301500
20	Hexagon socket head cap, M6xP1.0x16L	6		
21	Cap-right	1	1210301608	1210301608
22	Seal-oil	1		
23	Bearing-ball , 6204	1	91301018	91301018
24	Gear-"B" shaft (36T)	1	1210301706	1210301706
25	Snap ring , S25	2	9171S025	9171S025
26	Gear-"B" shaft	1	1210301804	1210301804
27	Gear-"B" shaft	1	1210301902	1210301902
28	Gear-"B" shaft	1	1210302007	1210302007
29	Gear-"B" shaft	1	1210302105	1210302105
30	Gear-"B" shaft	1	1210302203	1210302203
31	Ball bearing	1	91301006	91301006
32	Snap ring , S20	2		
33	Gear-"B" shaft	1	1210302301	1210302301
34	Key-square , 6x6x20L	2		
35	Shaft-"B"	1	1210302409	1210302409
36	Bearing-ball , 6003	3	91301005	91301005
37	Cap-left	1	1210302507	1210302507
38	Hexagon socket screw , M6xP1.0x12L	6		
39	Ring-"O" , P36	2		
40	Shaft-"C"	1	1210302605	1210302605
41	Gear-"C" shaft	1	1210302703	1210302703
42	Bearing , 6203	2	91301016	91301016
43	Shaft-"D"	1	1210302801	1210302801
44	Key-square , 6x6x146L	1		
45	Gear-"D" shaft	1	1210302909	1210302909

## GEAR BOX ASSEMBLY

Item No.	Part Name	Amt. Used	Type: 16 Part No.	Type: 18 Part No.
46	Gear-"D" shaft	1	1210303004	1210303004
47	Gear-"D" shaft	1	1210303102	1210303102
48	Gear-"D" shaft	1	1210303200	1210303200
49	Gear-"D" shaft	1	1210303308	1210303308
50	Gear-"D" shaft	1	1210303406	1210303406
51	Gear-"D" shaft	1	1210303504	1210303504
52	Gear-"D" shaft	1	1210303602	1210303602
53	Gear-"D" shaft	1	1210303700	1210303700
54	Gear-"D" shaft	1	1210303808	1210303808
55	Gear-"D" shaft	1	1210303906	1210303906
56	Gear-"D" shaft	1	1210304001	1210304001
57	Gear-"E" shaft	1	1210304109	1210304109
58	Shaft-"E"	1	1210304207	1210304207
59	Pin-taper	1	1003502904	1003502904
60	Bearing-thrust , 51104	2	91303003	91303003
61	Cap	1	1210304305	1210304305
62	Bearing-ball , 6004V	2	91301008	91301008
63	Shaft-"F"	1	1210304403	1210304403
64	Gear-"F" shaft	1	1210304501	1210304501
65	Shaft-"F" (left)	1	1210304609	1210304609
	(right)	1	1210304707	1210304707
66	Square key , 4x4x20L	2		
67	Bearing ball, 6005	2	91301010	91301010
68	Shaft-"G"	1	1210304805	1210304805
69	Gear-"G" shaft	1	1210304903	1210304903
70	Gear-"G" shaft	1	1210305008	1210305008
71	Gear-"H" shaft	1	1210305106	1210305106
72	Shaft-"H"	1	1210300209	1210300209
73	Key-square , 6x6x13L	1		
74	Cap-bearing	1	1210305204	1210305204
75	Bushing-"H" shaft	1	1210305302	1210305302
76	Bearing ball , 6004Z	1	91301007	91301007
77	Spacer	1	1121600905	1121600905
78	Gear-drive shaft (57T in )	1	1121600601	1121600601
79	Washer	1	1121602105	1121602105
80	Hexagon socket screw , M8xP1.25x16L	1		
81	Bolt-lock end cover	1	1122100208	1122100208
82	Stud	1	1121601108	1121601108
83	Washer, 1/2	1	1121602301	1121602301
84	Nut, W16	1		
85	Nut-lock stud	1	1121601706	1121601706
86	Quadrat	1	1121601000	1121601000
87	Stud-gear	1	1121601206	1121601206
88	Snap ring , R35	1		
89	Gear-quadrat (71T in)	1	1121600209	1121600209

## GEAR BOX ASSEMBLY

Item No.	Part Name	Amt. Used	Type: 16 Part No.	Type: 18 Part No.
90	Snap ring , S16	1		
91	Hexagon socket screw , M6xP1.0x25L	2		
91-1	Cover	1	1222100200	1222100200
92	Plug-oil inlet	1	1122101401	1122101401
93	Hexagon socket screw , M6xP1.0x65L	2		
94	Seat-pilot light		1210701206	1210701206
95	Lead-screw (5 feet in)	1	1210700209	1210700209
	(5 feet mm)	1	1210700101	1210700101
	(6 feet in)	1	1220700202	1220700202
	(6 feet mm)	1	1220700104	1220700104
	(8 feet in)	1	1230700205	1230700205
	(8 feet mm)	1	1230700107	1230700107
	(10 feet in)	1	1240700208	1240700208
	(10 feet mm)	1	1240700100	1240700100
96	Nut-lock	1	1210700709	1210700709
97	Bushing-leadscrew	1		
98	Plug-leadscrew	1	1210700709	1210700709
99	Supporter-for leadscrew, feed rod	1	1210700807	1210700807
100	Plug-oil inlet	1	1122101509	1122101509
101	Hexagon socket screw , M8xP1.25x30L	1		
102	Nut-lock	1	1210700709	1210700709
103	Plug-plastic	1	1122101607	1122101607
104	Rod-feed	1	1210700307	1210700307
105	Set screw , M6xP1.0x20L	2		
106	Pin-taper , 6x100L	1	1210700601	1210700601
107	Hexagon socket screw , M8xP1.25x80L	1		
108	Bushing-spindle starting rod	1	1210700905	1210700905
109	Rod-spindle starting switch (5 feet)	1	1210700405	1210700405
	(6 feet)	1	1220700408	1220700408
	(8 feet)	1	1230700401	1230700401
	(10 feet)	1	1240700404	1240700404
110	Seat-switch	1	1210701304	1210701304
111	Hexagon socket screw , M8xP1.25x25L	2		
112	Snap ring , S30	1		
113	Nut, M6xP1.0	1		
114	Set screw , M6xP1.0x20L	1	1210305400	1210305400
115	Bracket	1	1210701402	1210701402
121	Pin , 5x25L	1		

## GEAR BOX ASSEMBLY

Item No.	Part Name	Amt. Used	Type: 16 Part No.	Type: 18 Part No.
122	Screw socket headless set , M6xP1.0x8L	1		
123	Switch	2		
126	Knob	3	1120207400	1120207400
127	Hexagon socket screw , M10xP1.5x35L	4	1210701500	1210701500
128	Pin-taper , 0x38	1	1003502904	1003502904
128-1	Pin-taper , 6x45	1		
129	Hexagon socket screw , M8xP1.25x40L	7		
130	Screw-taper, oil outlet, PT3/8	1		
131	Screw-set, taper, PT1/8	1		
132	Shifter	2	1210305606	1210305606
133	Shoe-shifter	3	121030571	121030571
134	Shifter	1	1210306005	1210306005
135	Snap ring , S10	3		
136	Pin-spring , 5x26	3		
137	Shaft-shifter	3	1210306103	1210306103
138	Ring-"O" , P12	3		
139	Detent Plate	1	121030621	121030621
139-1	Detent Plate	1	1210306309	1210306309
139-2	Detent Plate	1	121030641	121030641
140	Ball-steel , 1/4	3		
141	Spring , 5x26	3		
142	Hub	3	1210306505	1210306505
143	Lever	3	1210306701	1210306701
144	Snap ring , S15	1		
145	Gear-drive bevel	1	1210306809	1210306809
146	Key-square , 5x5x15L	1		
147	Shaft-bevel gear	1	1210306907	1210306907
148	Seat-gear shifting	1	1210307002	1210307002
149	Ball-steel , 5/16	1		
150	Spring , 8x20	1		
151	Seal-oil , 20x35x10	1		
152	Hub	1	1210307100	1210307100
153	Handle	1	1120207204	1120207204
154	Pin , 5x50	1		
155	Snap ring , S18	2		

9-3 APRON

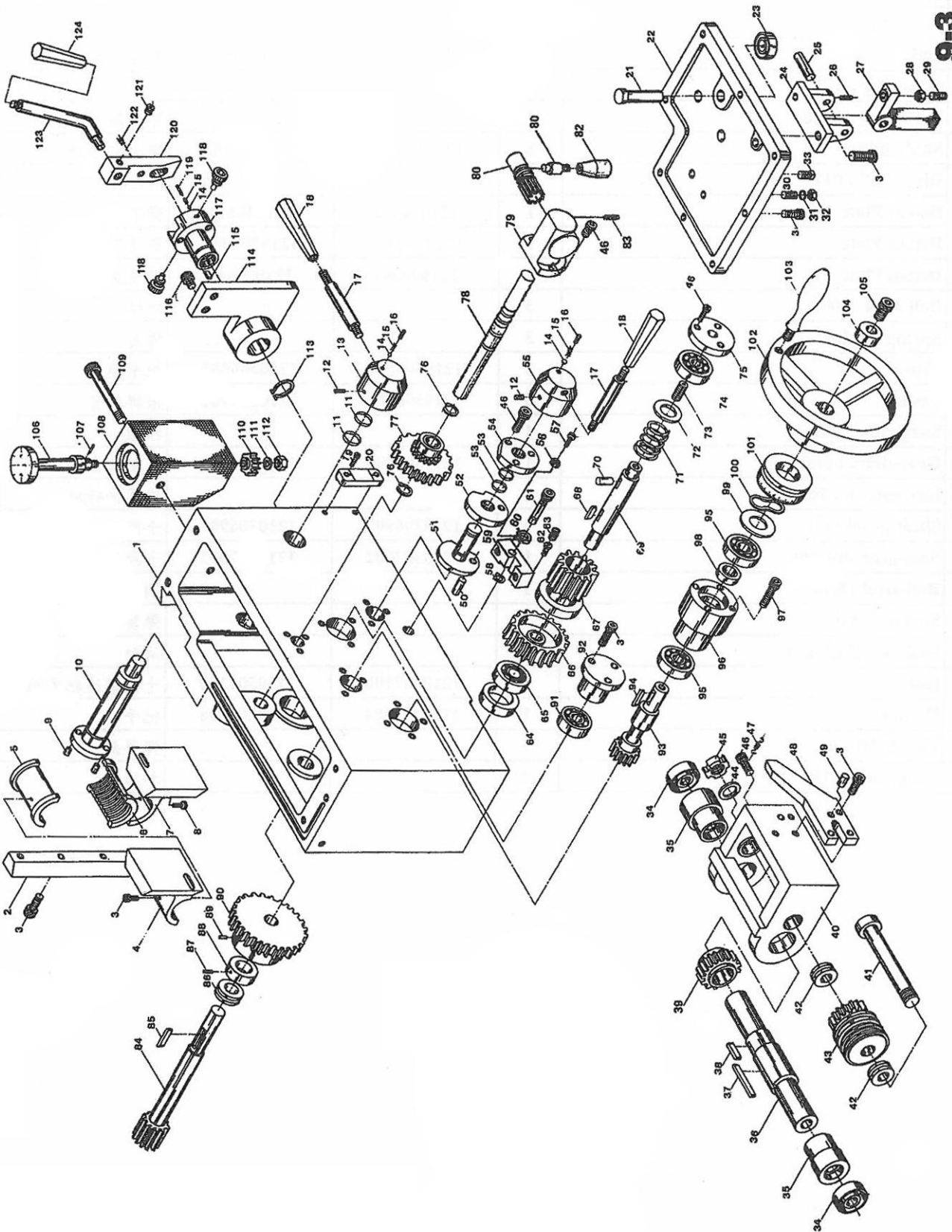

## APRON ASSEMBLY

Item No.	Part Name	Amt. Used	Type: 16 Part No.	Type: 18 Part No.
1	Body-Apron (right)	1	1210900209	1210900209
	(left )	1	1210900101	1210900101
2	Gib	1	1210901706	1210901706
3	Hexagon socket screw , M6xP1.0x16L	17		
4	Holder-half nut (right)	1	1210900405	1210900405
	(left)	1	1210900307	1210900307
5	Nut-half (in)	1	121090051	121090051
	(mm)	1	121090061	121090061
6	Nut-half (in)	1	121090051	121090051
	(mm)	1	121090061	121090061
7	Holder-half nut	1		
8	Hexagon socket screw , M6xP1.0x16L	1		
9	Pin-sliding	2	1210902507	1210902507
10	Shaft-haft nut (right)	1	1210900807	1210900807
	(left)	1	1210900709	1210900709
11	Ring-O , P26	2		
12	Set screw , M8xP1.25x20L	2	1210902605	1210902605
13	Hub (right)	1	121090141	121090141
	(left)	1	1210901304	1210901304
14	Ball-steel , 1/4"	3		
15	Spring , Ø 1x6x30L	3		
16	Set screw , M8xP1.25x10L	2		
17	Lever	2	1210902703	1210902703
18	Knob	2	1120207400	1120207400
19	Hexagon socket screw , M10xP1.5x25L	2		
20	Lenx-oil	1	1210902801	1210902801
21	Shaft-auto stop	1	1210902909	1210902909
22	Cover-bottom apron	1	1210903004	1210903004
23	Seal-oil , 15x25x7	1		
24	Seat-tappet	1	1121601804	1121601804
25	Shaft-tappet	1	1121601902	1121601902
26	Set screw , M6xP1.0x16L	2		
27	Tappet	1	1121602007	1121602007
28	Nut , M8xP1.25	1		
29	Set screw , M8xP1.25x30L	1		
30	Set screw , M6xP1.0x40L	1		
31	Set screw , M6x40	1		
32	Nut , M6xP1.0	2		
33	Screw-oil leakage , PT1/4	1	92590601	92590601
34	Seal-oil , 32x42x10	1		
35	Bushing	2	1210901804	1210901804
36	Sleeve-feed rod	1	1210901902	1210901902
37	Key-square , 6x6x42L	1		

## APRON ASSEMBLY

Item No.	Part Name	Amt. Used	Type: 16 Part No.	Type: 18 Part No.
38	Key-square , 6x6x12L	1		
39	Gear	1	1210903200	1210903200
40	Seat-worm	1	1210903308	1210903308
41	Shaft-worm	1	1210903406	1210903406
42	Bearing-thrust , 2904	2	91311005	91311005
43	Worm gear	1	1210902007	1210902007
44	Washer-lock , 20	1		
45	Nut	1		
46	Hexagon socket screw , M6xP1.0x12L	8		
47	Spring, $\emptyset$ 1x10x60L (right)	1	1210905400	1210905400
	(left)	1	1210905508	1210905508
48	Block-safe device (right)	1	1210901000	1210901000
	(left)	1	1210900905	1210900905
49	Pin, 5x18L	2		
50	Pin	1		
51	Shaft-auto feed (right)	1	1210901206	1210901206
	(left)	1	1210901108	1210901108
52	Collar (right)	1	1210901206	1210901206
53	Ring-O , P16	2		
54	Cover	1	1210903602	1210903602
55	Hub (right)	1	121090141	121090141
	(left)	1	1210901304	1210901304
56	Spring washer , M8	1		
57	Hexagon socket screw , M8xP1.25x12L	1		
58	Snap ring, S10	1		
59	Lever	1	1210903700	1210903700
60	Spring washer, M12	1		
61	Screw	1		
62	Hexagon socket screw , M5xP0.8x20L	1		
63	Spring	1	1210905606	1210905606
64	Spacer	1	1210903906	1210903906
65	Bearing ball, 6005V	1	91301012	91301012
66	Worm-wheel	1	1210902105	1210902105
67	Wheel-friction	1	1210902203	1210902203
68	Key-square, 7x7x12L	1		
69	Shaft-worm wheel	1	1210904001	1210904001
70	Pin	1	1210904109	1210904109
71	Spring, compressing	1	1210905302	1210905302
72	Washer	1	1210904207	1210904207
73	Set screw	1		
74	Bearing-ball , 6204	1	91301018	91301018
75	Cover	1	1210904305	1210904305
76	Snap ring , S20	2		
77	Gear	1	1210902301	1210902301
78	Shaft-cross feed	1	1210904403	1210904403



## APRON ASSEMBLY

Item No.	Part Name	Amt. Used	Type: 16 Part No.	Type: 18 Part No.
79	Set (right)	1	1210901608	1210901608
	(left)	1	1210901500	1210901500
80	Shaft-lever	1	1210904501	1210904501
81	Lever	1		
82	Sleeve-lever	1		
83	Set screw , M4xP0.7x10L	1		
84	Pinion-rack	1	1210904707	1210904707
85	Key-square , 6x6x20L	1		
86	Bearing-niddle , NK20/22	1	91311001	91311001
87	Set screw , M6xP1.0x10L	1		
88	Collar	1	1210904805	1210904805
89	Pin-spring , 6x36L	1		
90	Gear	1	1210904903	1210904903
91	Bearing-ball , 6003	1	91301005	91301005
92	Cover	1	1210905008	1210905008
93	Pinion-handwheel		1210905106	1210905106
94	Key-square , 6x6x25L	1		
95	Bearing-ball , 6004V	1	91301008	91301008
95-1	Bearing-ball , 6005Z	1	91301007	91301007
96	Seat		1210905204	1210905204
97	Hexagon socket screw , M6xP1.0x30L	4		
99	Washer		1210701608	1210701608
100	Washer-wave type	1		
101	Dial-rack	1	1220900202	1220900202
102	Handwheel	1	112210171	112210171
103	Handle	1	1121102002	1121102002
104	Washer-lock	1	1122101901	1122101901
105	Hexagon socket screw , 8xP1.25x20L	1		
106	Dial-thread chasing (in, 4 parts)	1	1003514708	1003514708
	(mm, 5 parts)	1	1003502404	1003502404
	(mm, 7 parts)	1	1003514904	1003514904
107	Pin	1		
108	Seat-dial shaft	1	1003514502	1003514502
109	Hexagon socket screw , 10xP1.5x65L	1		
110	Gear (in 16T)	1	1003514600	1003514600
	(mm 11T)	1	1003502502	1003502502
	(mm 13T)	1	1003502600	1003502600
	(mm 14T)	1	1003514806	1003514806
	(mm 15T)	1	1003502708	1003502708
	(mm 18T)	1	1003502806	1003502806
111	Washer-spring , 10	1		
112	Nut , M10xP1.5	1		
113	Snap ring , S30	1		

## APRON ASSEMBLY

Item No.	Part Name	Amt. Used	Type: 16 Part No.	Type: 18 Part No.
114	Seat-switch	1	1210701706	1210701706
115	Key-square , 6x8x25L	1		
116	Hexagon socket screw , M8xP1.25x16L	2		
117	Bracket	1	1210701804	1210701804
118	Screw-lock	2	1210701902	1210701902
119	Screw-hexa. socket headless cap, M8xP1.25x8L	1	1210702007	1210702007
120	Seat-lever	1	1210702105	1210702105
121	Set screw , M8xP1.25x8L	2	91120808	91120808
122	Spring	1		
123	Lever	1	1210702203	1210702203
124	Sleeve-lever	1	1122103601	1122103601

# 9-4 BED AND BASE

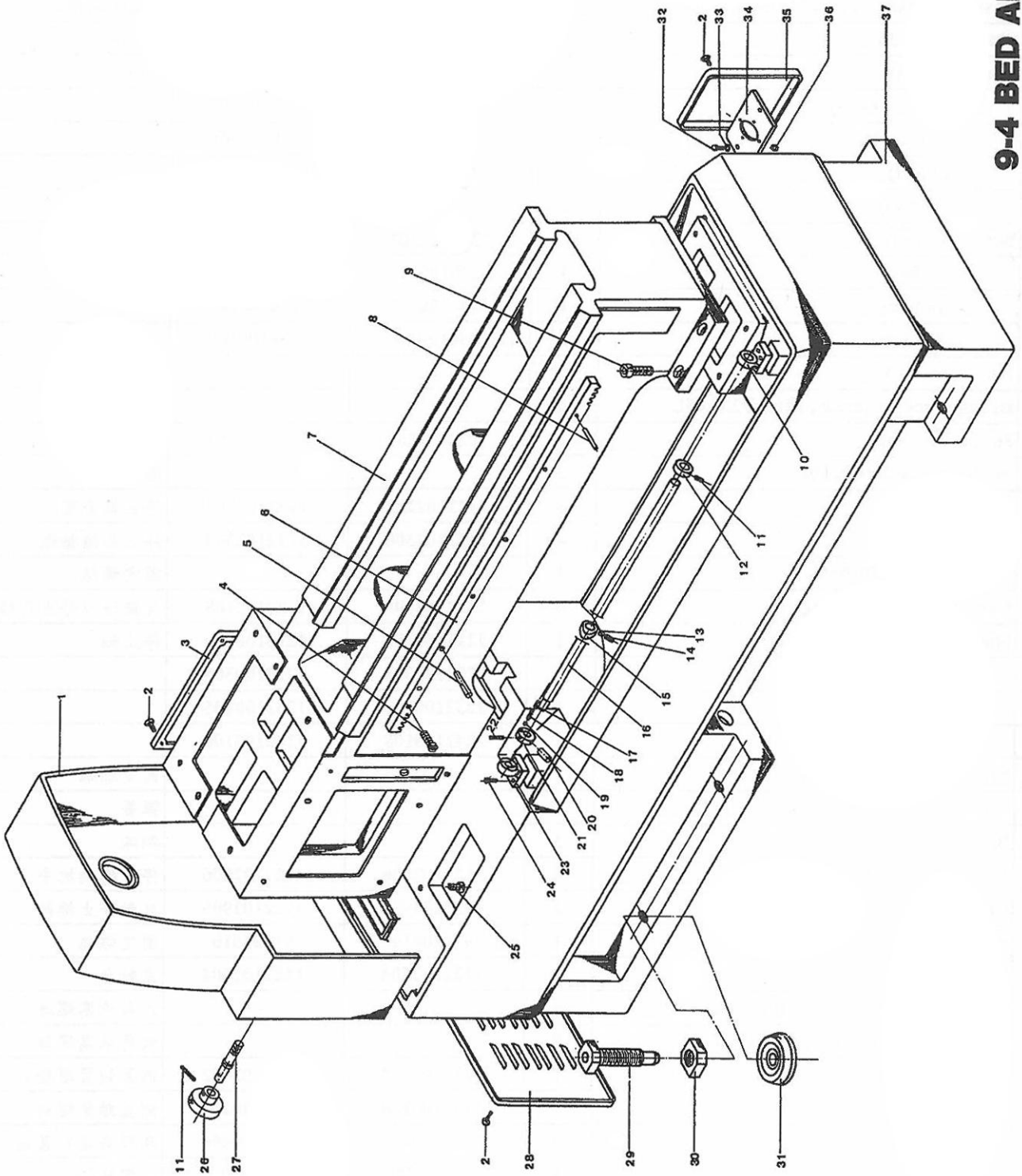

## BED AND BASE ASSEMBLY

Item No.	Part Name	Amt. Used	Type: 17 Part No.	Type: 19 Part No.
1	Cover-end	1	1221600201	1221600201
2	Screw-cross-recessed head, M6xP1.0x20L	12		
3	Cover-electric box	1	1122102006	1122102006
4	Hexagon socket screw , M6xP1.0x25L	10		
5	Pin-taper, 6x36	2		
6	Rack (5 feet )	1	1210701000	1210701000
	(6 feet , right)	1	1220700604	1220700604
	(6 feet , left)	1	1220700506	1220700506
	(8 feet)	1	1230700509	1230700509
	(10 feet)	1	1240700502	1240700502
7	Bed (5 feet)	1	1210100101	1210100101
	(6 feet)	1	1220100104	1220100104
	(8 feet)	1	1230100107	1230100107
	(10 feet)	1	1240100100	1240100100
8	Pin-taper , 6x36	2		
9	Hexagon socket screw , M16xP2.0x45L	4		
10	Supporter-shaft	1	1122102104	1122102104
11	Set screw , M6xP1.0x10L	2		
12	Collar	1	1122102202	1122102202
13	Shoe-brass	4	1122102300	1122102300
14	Set screw , M6xP1.0x6L	1		
15	Cam-auto feed stopping	4	1122102408	1122102408
16	Shaft-auto stopping (5 feet)	1	1212100109	1212100109
	(6 feet)	1	1222100308	1222100308
	(8 feet)	1	1232100105	1232100105
	(10 feet)	1	1242100108	1242100108
17	Set screw , M8xP1.25x8L	1		
18	Spring , 1x6x8L	1		
19	Ball-steel , 1/4"	1		
20	Lever-turning shaft	4	1122102506	1122102506
21	Collar	1	1122103905	1122103905
22	Set screw , M8xP1.25x10L	1	91120810	91120810
23	Supporter-shaft	1	1122102604	1122102604
24	Hexagon socket screw , M8xP1.25x16L	4		
25	Hexagon socket screw , M16xP2.0x55L	8		
26	Plug	1	1122102702	1122102702
27	Bolt-lock	1	1122100208	1122100208
28	Cover-motor seat	2	1122100806	1122100806
29	Bolt-set machine	6	112210281	112210281
30	Nut-lock	6	1122102800	1122102800

### BED AND BASE ASSEMBLY

Item No.	Part Name	Amt. Used	Type: 17 Part No.	Type: 19 Part No.
31	Block-leveling	6	1003501809	1003501809
32	Bolt-hexa. head , W1/4"x25	2		
33	Washer, W5/8"	2		
34	Seat-coolant pump	1	121010051	121010051
35	Cover-coolant motor seat	1	1005000403	1005000403
36	Nut-lock , W1/4"	2		
37	Base (5 feet)	1	1210100209	1210100209
	(6 feet)	1	1220100202	1220100202
	(8 feet)	1	1230100205	1230100205
	(10 feet)	1	1246100208	1246100208

# 9-5 BRAKE SYSTEM

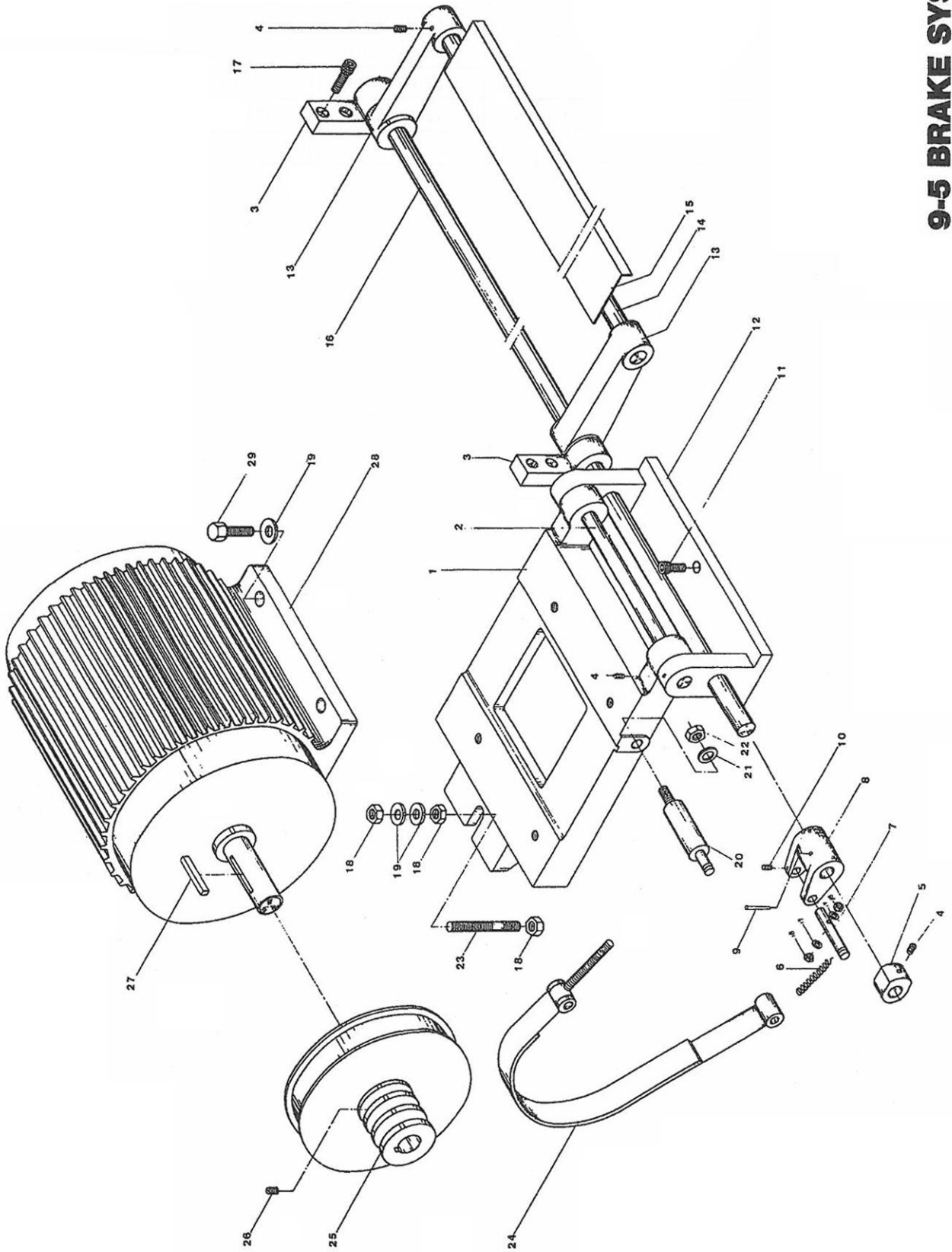

## BRAKE SYSTEM ASSEMBLY

Item No.	Part Name	Amt. Used	Type: 17 Part No.	Type: 19 Part No.
1	Seat-motor	1	1210400606	1210400606
2	Shaft-motor seat	1	1210400204	1210400204
3	Block	2	1210100601	1210100601
4	Screw-hexa. socket headless set, M6xP1.0x15L	4		
5	Cam	1	1210400606	1210400606
6	Spring	1	1210400302	1210400302
7	Shaft-brake	1	1210400704	1210400704
8	Arm-brake	1	1210400802	1210400802
9	Pin-taper , 4"x38L	1		
10	M6xP1.0x10L	1		
11	Hexagon socket screw , M10xP1.5x20L	3		
12	Bracket-motor seat	1	1210100709	1210100709
13	Bracket-pedal	2	1210400900	1210400900
15	Pedal-brake (5 feet)	1	1210400508	1210400508
	(6 feet)	1	1220400109	1220400109
	(8 feet)	1	1230400102	1230400102
	(10 feet)	1	1240400105	1240400105
16	Shaft-pedal bracket (5 feet)	1	1210100105	1210100105
	(6 feet)	1	1220100300	1220100300
	(8 feet)	1	1230100401	1230100401
	(10 feet)	1	1240100404	1240100404
17	Hexagon socket screw , M10xP1.25x20L	4		
18	Nut , M16	5		
19	Washer , M16	8		
20	Bolt-adjusting	1	1210401005	1210401005
21	Washer , M12	1		
22	Nut , M12	1		
23	Bolt-adjusting	1	1210400400	1210400400
24	Belt-brake (5HP , 15HP)	1	1003519605	1003519605
	(7.5HP , 10HP)	1	1003519703	1003519703
25	Belt pulley (5HP/60HZ)	1	3005025	3005025
	(7.5HP, 10HP/60HZ)	1	3005025-004	3005025-004
26	Set screw , M8xP1.25x8L	1		
27	Key, 8x7.5x40 (5HP)	1		
	10x8x65 (7.5HP)	1		
	(10HP)	1		
	12x8x80 (15HP)	1		
28	Motor (5HP/220/440/60)	1	81000103	81000103
	(7.5HP/220/440/60)	1	81000205	81000205
29	Bolt-hexa. head , M10x30L	4		

**9-6 CARRIAGE AND CROSSFEED**

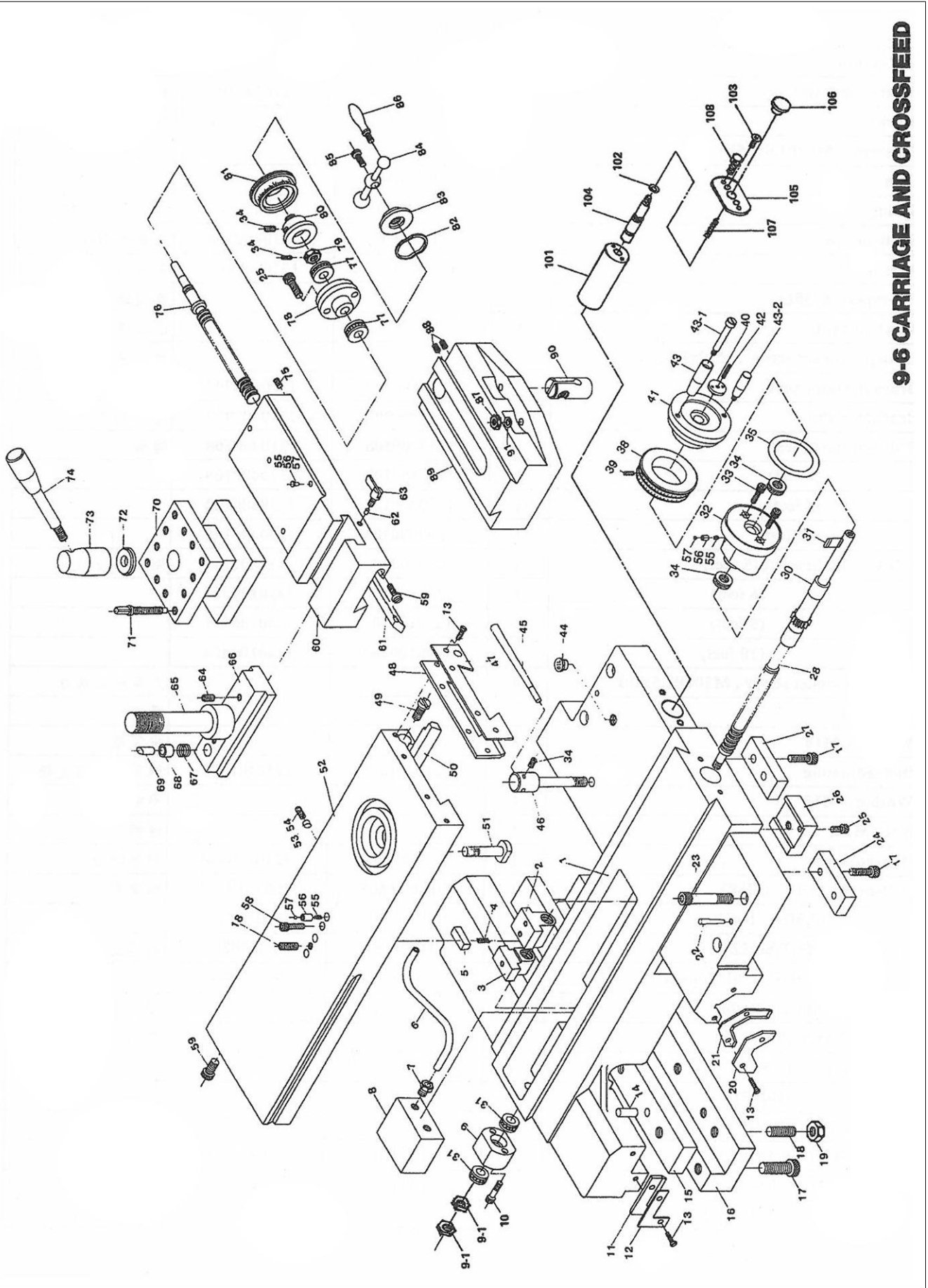



**9-6A CARRIAGE AND CROSSFEED**

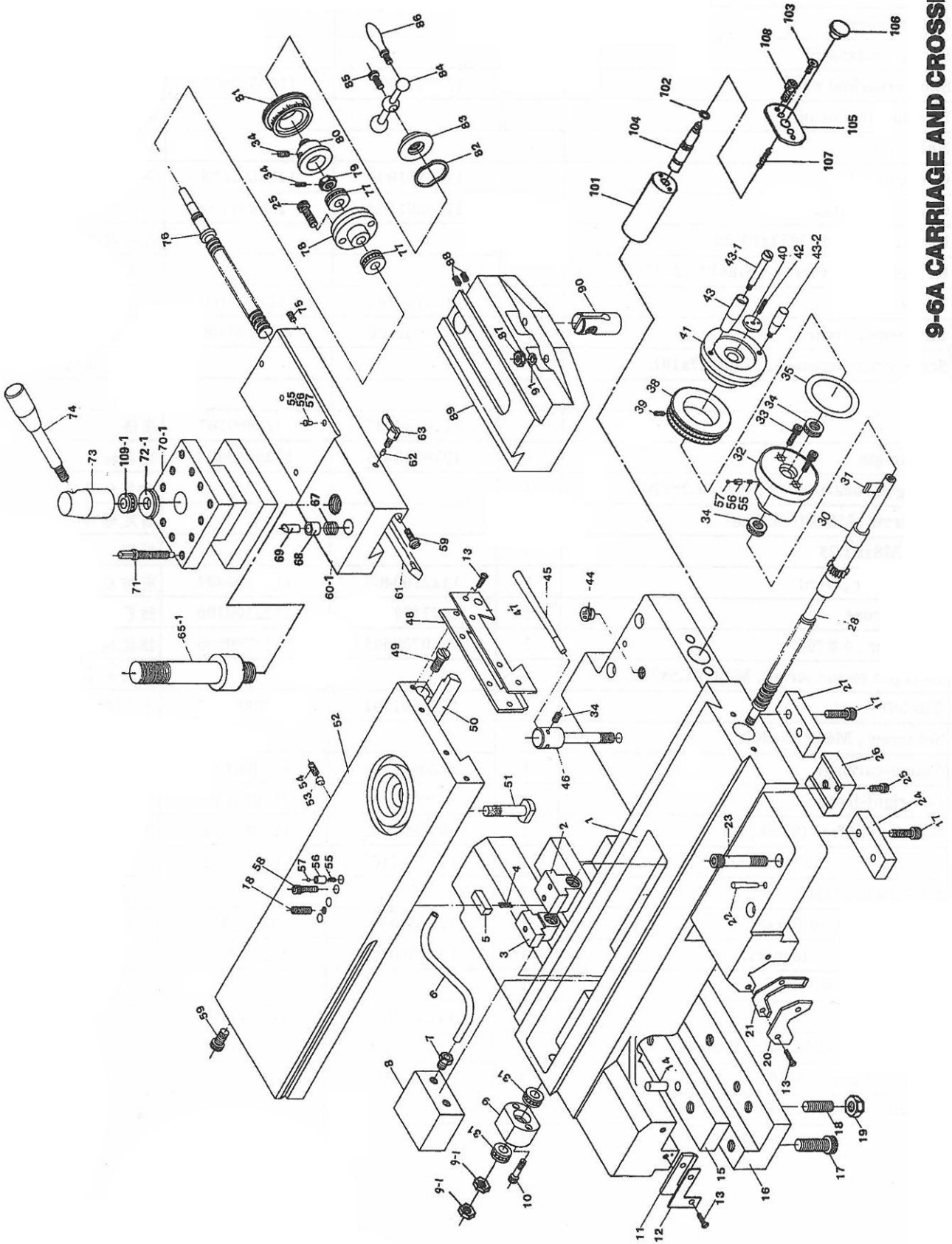

## CARRIAGE AND CROSSFEED ASSEMBLY

Item No.	Part Name	Amt. Used	Type: 17 Part No.	Type: 19 Part No.
1	Carriage	1	122080109	122080109
2	Nut-crossfeed	1		
3	Nut-crossfeed	1		
4	Spring, 0.3x5x15L	1		
5	Shim-crossfeed nut	1	1120800901	1120800901
6	Pipe-lubrication oil	1		
7	Nut-copper	1		
8	Conveyor-oil	1	1120801006	1120801006
9	Cap-crossfeed screw	1	1120801104	1120801104
9-1	Nut-hexa. Head, M12xP1.25	1		
10	Hexagon socket screw, M8xP1.25x35L	2		
11	Wiper-rear	1	1122100100	1122100100
12	Case-wiper , rear	1	1122100306	1122100306
13	Screw-cross-recessed, M4xP0.7x10L	8		
14	Pin	2		
15	Gib	1	1220800207	1220800207
16	Holder-gib	1	1220800403	1220800403
17	Hexagon socket screw, M8xP1.25x20L	2		
18	Set screw, M8xP1.25x20L	5		
19	Nut , M8xP1.25	4		
20	Case-wiper, front	1	1122100404	1122100404
21	Wiper-front	1	1122100100	1122100100
22	Pin-taper, 6 # 75L	2	1210700503	1210700503
23	Hexagon socket screw, M10xP1.5x70L	4		
24	Gib-left-front	1	1120801202	1120801202
25	Set screw , M6xP1.0x20L	3		
26	Clamp-carriage	1	1120801300	1120801300
27	Gib-right-front	1	1120801408	1120801408
28	Screw-crossfeed (8TPI , in)	1	1000800403	1000800403
	(5MM , mm)	1	1000800109	1000800109
29	Pin-spring , 5x30L	1		
30	Pinion-crossfeed (local)	1	1220800501	1220800501
	(export)	1	1220800609	1220800609
31	Bearing thrust, 51101	1		
32	Bracket	1	1120800107	1120800107
33	Bolt-hexa. Socket, M8xP1.25x40L	2		
34	Bearing-thrust, 51103	2	91303002	91303002
35	Washer-wave type, 6210	2		
36	Set screw , M6xP1.0x10L	1		
37	Clutch-dial	1	1120802807	1120802807

## CARRIAGE AND CROSSFEED ASSEMBLY

Item No.	Part Name	Amt. Used	Type: 17 Part No.	Type: 19 Part No.
38	Dial-crossfeed (8TPI/export)	1	1000808203	1000808203
	(5MM/export)	1	1000802603	1000802603
39	Hexagon socket screw , M6xP1.0x15L	1		
40	Set screw	1	1120803000	1120803000
41	Handle-wheel (local)	1	1120802601	1120802601
	(export)	1	1120802709	1120802709
42	Screw-adjusting , M6xP1.0x30L	1		
43	Knob-handle (local)	1	1120803206	1120803206
	(export)	1	1120803304	1120803304
43-1	Screw-handle (export)	1		
43-2	Knob-handle	1	1120803402	1120803402
44	Plug-oil inlet	1	1122103405	1122103405
45	Lever	1	1120801506	1120801506
46	Screw-carriage clamp	1	1120800607	1120800607
47	Case-wiper	1		
48	Wiper	1	1222100102	1222100102
49	Screw-adjusting	1		
50	Gib	1	1220800305	1220800305
51	Bolt	1	1120800509	1120800509
52	Cover-cross sliding	1	1430800802	1430800802
53	Shoe-clamp	1	1220800707	1220800707
54	Set screw, M8xP1.25x20L	1		
55	Spring	1		
56	Button	1		
57	Ball-steel , 1/4"	1		
58	Hexagon socket screw , M6xP1.0x3	3		
59	Screw-gib	2		
60	Compound rest	1		
61	Gib-compound rest	1	1000804509	1000804509
62	Shoe-clamp	1	1220800707	1220800707
63	Screw-clamp	1		
64	Screw-hexa. socket headless cap , M8xP1.25x10L	4		
65	Shaft-tool post	1		
65-1	Shaft-tool post	2		
66	Block-tee	1		
67	Spring , 1x8x20L	1		
68	Sleeve	1		
69	Button	1		
70	Tool post square (export)	1	1003512802	1003512606
	(local)	1	1003512704	1003512508
71	Screw-square head	1	1000804107	1000804107
72	Bearing-thrust, 51104	1	91303003	91303003
73	Knob-lever	1	1000810605	1000810605
74	Lever	1	1000810605	1000810605
75	Screw-gib, M8xP1.25x31L	1		
76	Screw-compound rest	1	1000803904	1000803904

## CARRIAGE AND CROSSFEED ASSEMBLY

Item No.	Part Name	Amt. Used	Type: 17 Part No.	Type: 19 Part No.
77	Bearing-thrust, 51102	2		
78	Seat-compound rest screw	1		
79	Nut	1		
80	Collar	1		
81	Dial-compound rest	1	1000820003	1000820003
82	Washer-wave type	1		
83	Nut	1		
84	Handle	1		
85	Hexagon socket screw , M6xP1.0x16L	1		
86	Knob-handle	1		
87	Nut, M10xP1.5	4		
88	Set screw , M8xP1.25x8L	2		
89	Swivel	1		
90	Nut-compound rest screw	1		
91	Spring washer , M10	4		
101	Body-pump	1	1120801800	1120801800
102	Ring-O , P10	1		
103	Screw , M5xP0.8x12L	2		
104	Rod-pump	1	1120801908	1120801908
105	Stopper	1	1120802003	1120802003
106	Plug	1	1120802101	1120802101
107	Spring-compressing, $\emptyset$ 1.2x10x63L	1		
108	Screw-hexa. Socket head cap, M6xP1.0x16L	2		

# 9-7 TAIL STOCK

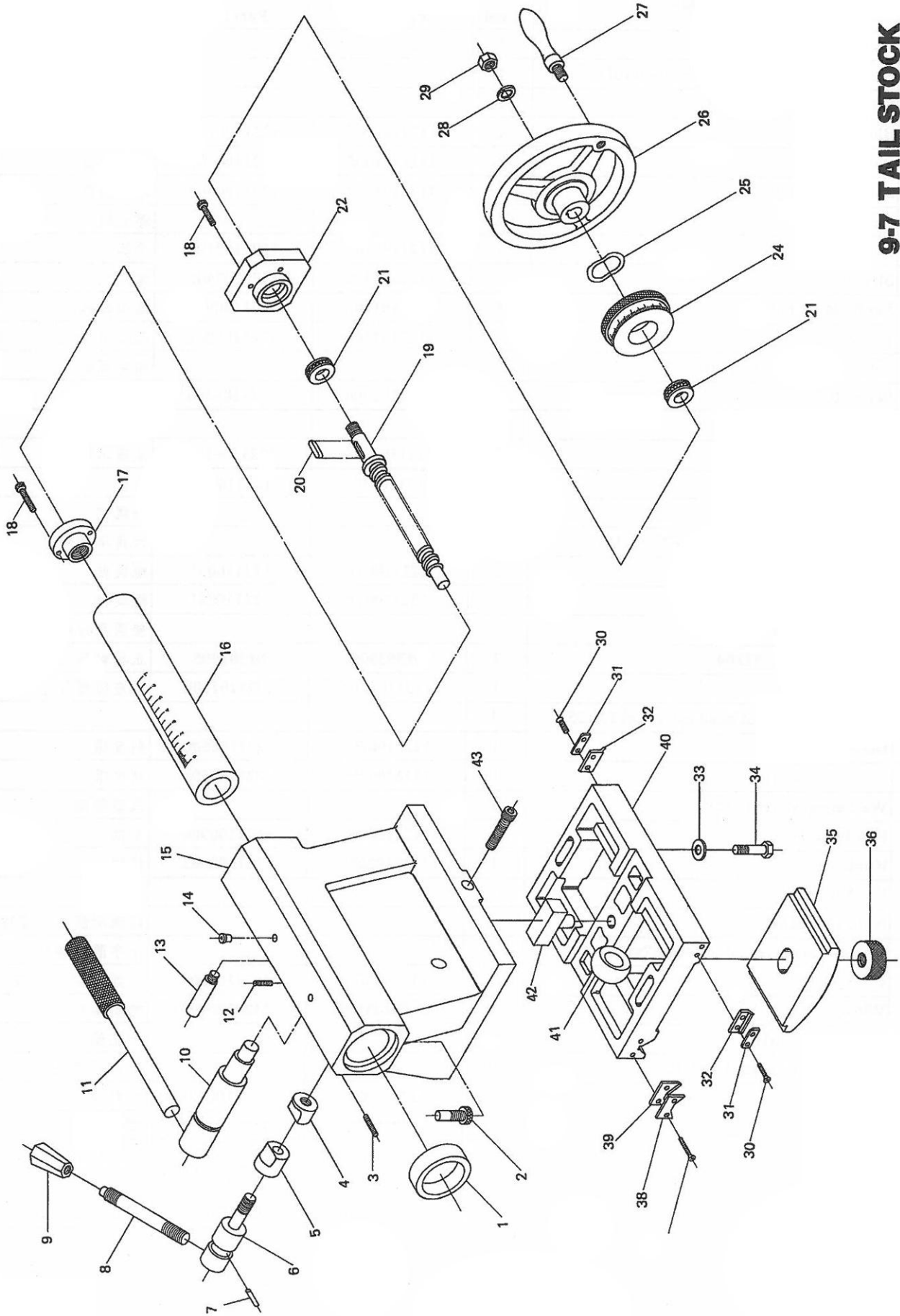

## TAILSTOCK ASSEMBLY

Item No.	Part Name	Amt. Used	Type: 17 Part No.	Type: 19 Part No.
1	Seal-oil , TC68x90x12	1		
2	Hexagon socket screw , M8xP1.25x10L	1		
3	Set screw , M6xP1.0x10L	1		
4	Block-clamp	1	1121101005	1121101706
5	Block-clamp	1	1121101005	1121101706
6	Shaft-clamp spindle	1	1121101103	1121101804
7	Pin, 5x12	1		
8	Lever	1	1121102100	1121102100
9	Sleeve-lever	1	1120207400	1120207400
10	Shaft-clamp bottom	1	1121101201	1221100902
11	Lever	1	1121101201	1221100902
12	Set screw , M6xP1.0x20L	1		
13	Screw-brake	1	1121102306	1121102306
14	Plug-oil	3		
15	Body-tailstock	1	1121100106	1121100106
16	Spindle-tang slot	1	1121101309	1121101309
17	Cap-spindle	1		
18	Hexagon socket screw , M6xP1.25x10L	3		
19	Screw-spindle feed (in)	1	122110031	122110031
	(mm)	1	122110041	122110041
20	Key-square , 6x6x25	1		
21	Bearing-thrust , 51204	2	91303005	91303005
22	Cap-body end	1	1121101407	1221101105
23	Screw-hexa. Socket head cap, 96xP1.0x25L	4		
24	Dial-feed (in)	1	1121100508	1221100500
	(mm)	1	1121100606	1221100608
25	Washer-wave type, 6205	1		
26	Handwheel	1	1121100900	1121100900
27	Knob	1	1121102002	1121102002
28	Washer , 1/2"	1		
29	Nut , 1/2-20UNF	1		
30	Screw-cross-recessed, M4xP0.7x12L	4		
31	Case-wiper	2	1122100600	1122100600
32	Wiper	2	1122100100	1122100100
33	Washer-flat, M10	2		
34	Bolt-clamp, M10xP1.5x75L	2		
35	Clamp	1	1122100708	1122100708
36	Washer	1	1122103503	1122103503
38	Case	1	1122100502	1122100502
39	Wiper	1	1122100100	1122100100
40	Bottom-tailstock	1	122110141	122110021
41	Bolt-clamp	1		
42	Block-adjusting	1	1221101301	1221101301
43	Screw-hexa. socket, M10xP1.5x80L	2		

# 9-8 STEADY REST

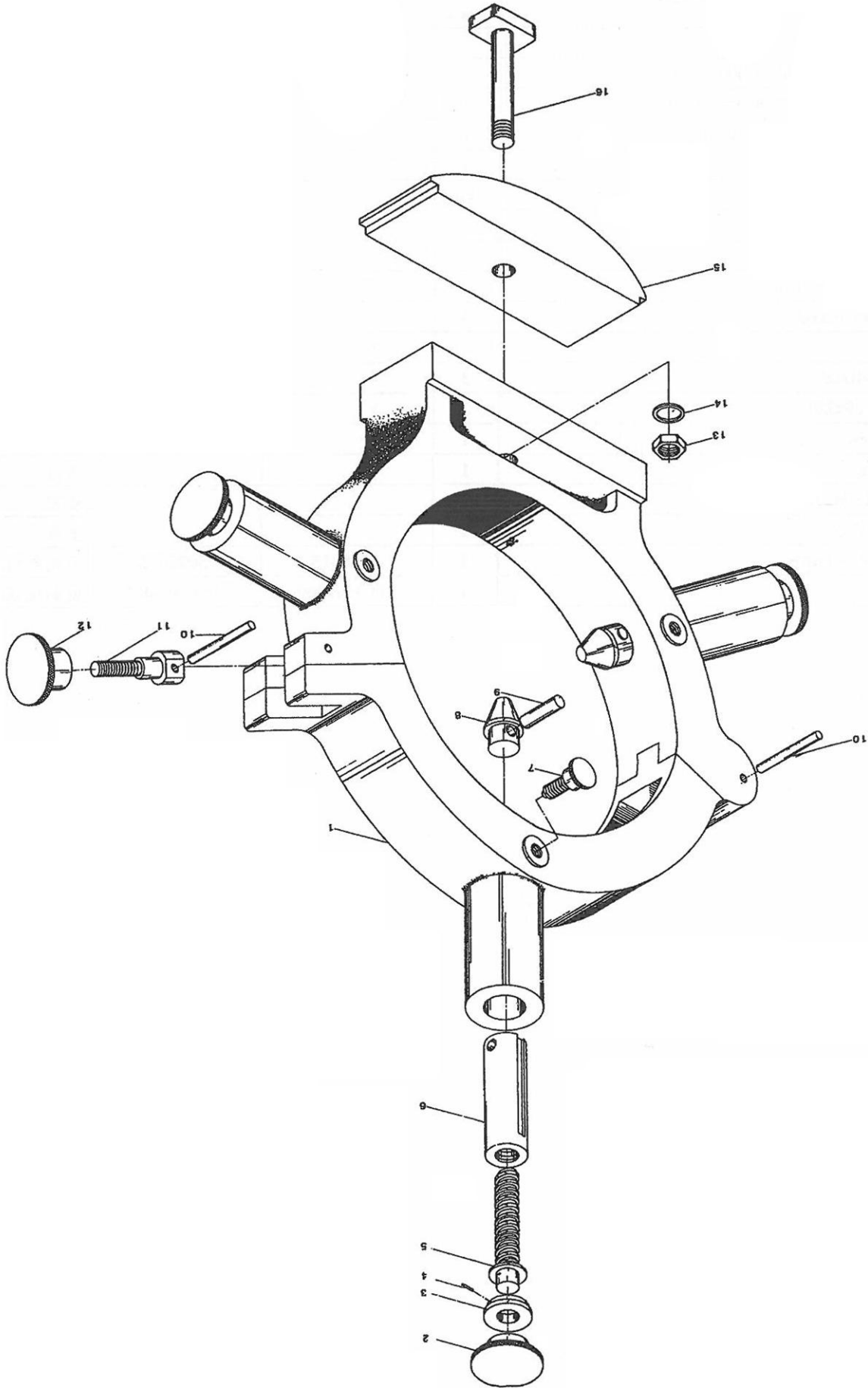

## STEADY REST

Item No.	Part Name	Amt. Used	Type: 17 Part No.	Type: 19 Part No.
1	Steady-rest (6" Bronze tip type)	1	1003519203	1003501103
	(6" Roller type)	1	1003519301	1003501201
	(9" Bronze tip type)	1		1003501309
	(9" Roller type)	1		1003501407
2	Plug-lead screw	3		
3	Cap, 6x52L	12		
4	Pin	3		
5	Lead-screw	3		
6	Nut-lead screw	3		
7	Screw-fixed	3		
8	Jaw	3		
9	Pin-fixed	3		
10	Pin , 9x25L	2		
11	Screw	1		
12	Plug	1		
13	Nut , W5/8"	1		
14	Washer	1		
15	Block-clamp	1	3008015	3008015
16	Bolt	1	1003500400	1003500400



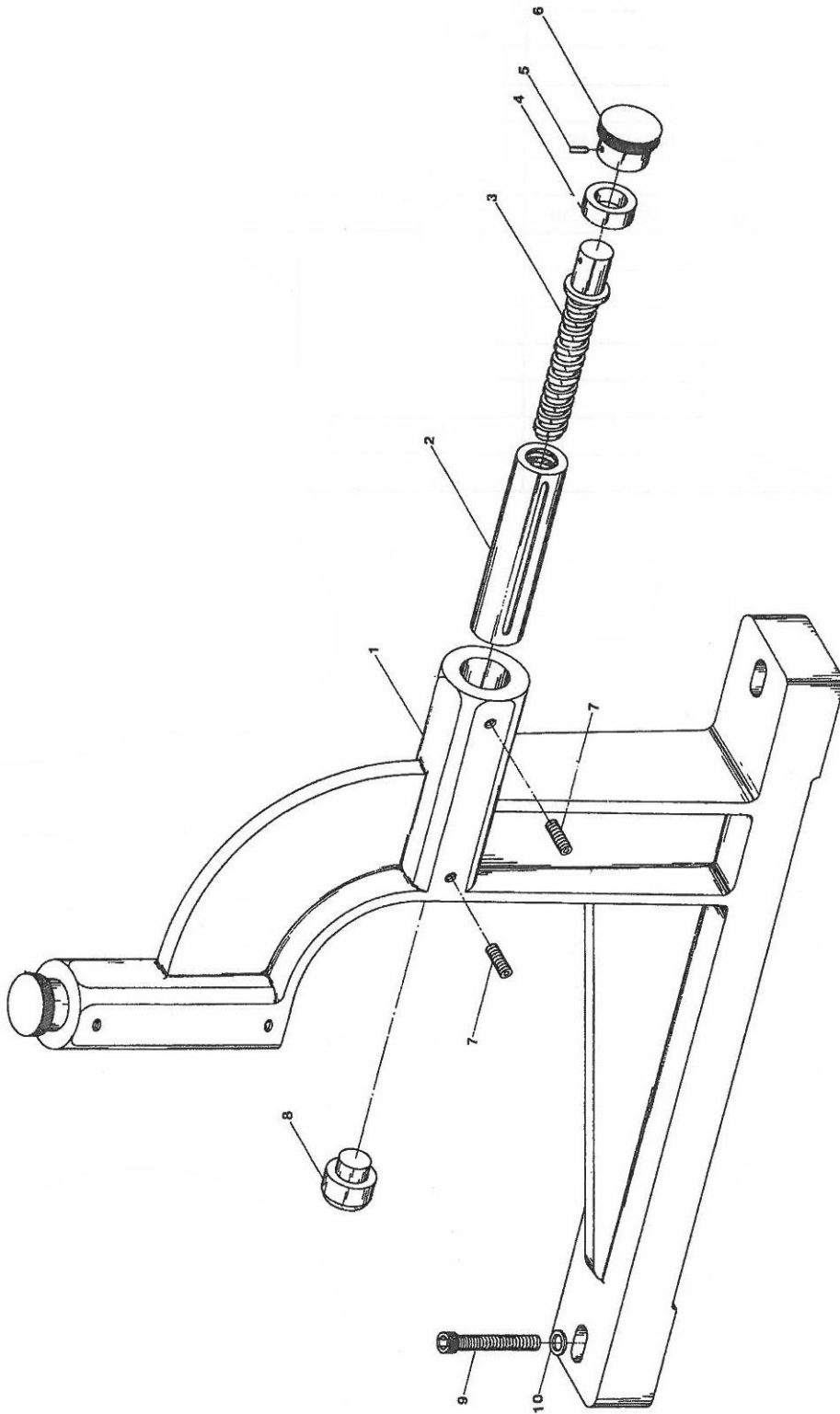

**9-9 FOLLOW REST**

### FOLLOW REST ASSEMBLY

Item No.	Part Name	Amt. Used	Type: 17 Part No.	Type: 19 Part No.
1	Body-follow rest (Bronze tip type)	1	10035019409	1003503107
	(Roller type)	1	100352700	100352710
2	Nut-lead screw	2		
3	Lead-screw	2		
4	Collar	2		
5	Pin , 4x25L	2		
6	Plug-lead screw	2		
7	Screw-hexa. socket headless cap, M8xP1.25x10L	4		
8	Shoe	2		
9	Screw-hexa. Socket head cap, M10xP1.5x30L	2		
10	Washer	2		

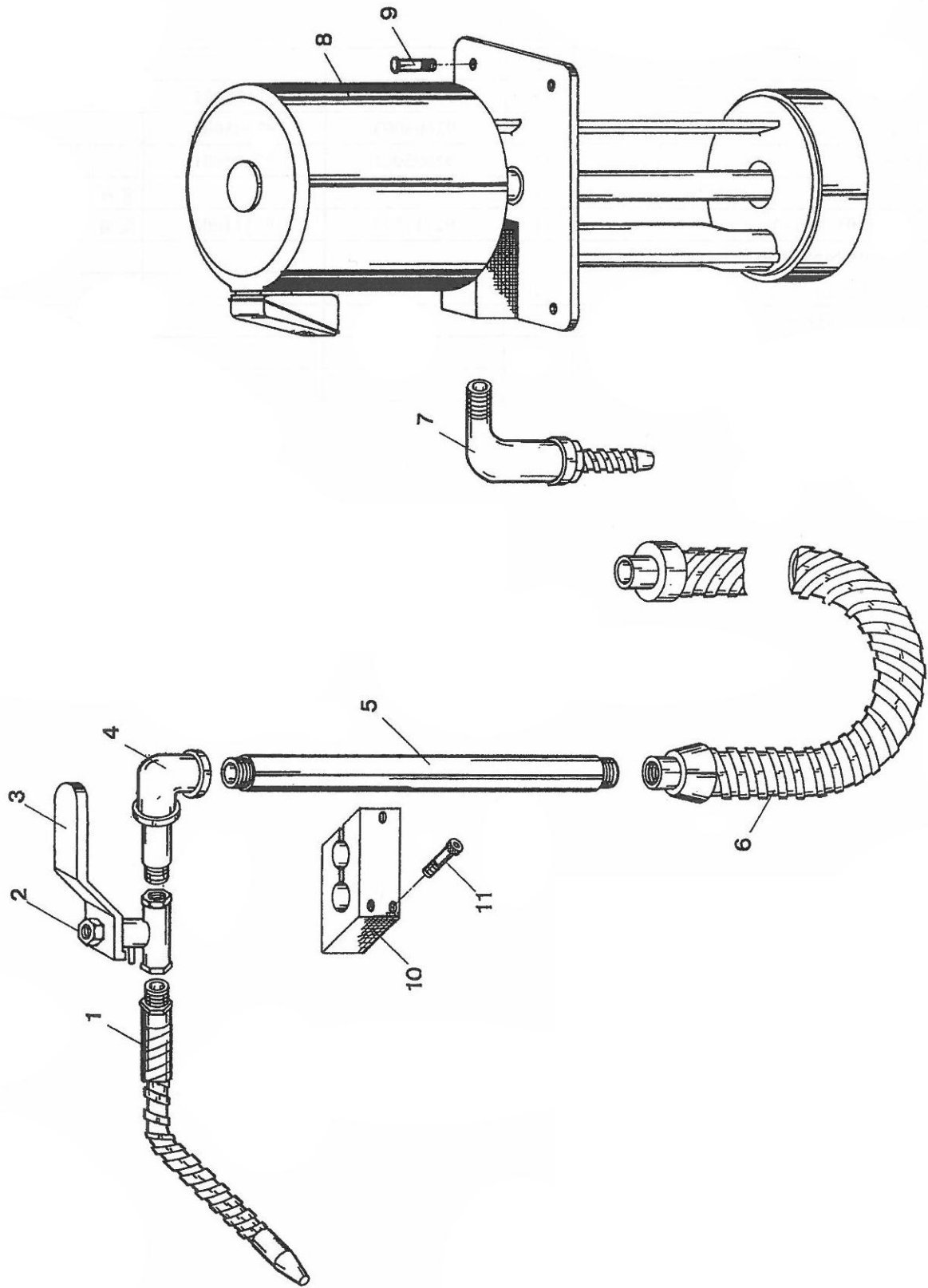

## 9-10 COOLANT SYSTEM

## COOLANT SYSTEM ASSEMBLY

Item No.	Part Name	Amt. Used	Type: 17 Part No.	Type: 19 Part No.
1	Nozzle	1		
2	Nut-lock	1		
3	Cock-lever	1		
4	Elbow	1		
5	Metal pipe	1		
6	Pipe (5, 6 feet)	1	92605002	92605002
	(8 feet)	1	92605003	92605003
	(10 feet)	1	92605001	92605001
7	Elbow	1		
8	Pump body (220V/440V)	1	92111802	92111802
9	Bolt-hex. Head , M6xP1.0x12L	2		
10	Supporter-lock pipe	1		
11	Screw-hexa. Socket head cap, M6xP1.10x20L	3		